



Mind the Gap!

Mathematics
Study Guide

Grade
12



basic education

Department:
Basic Education
REPUBLIC OF SOUTH AFRICA

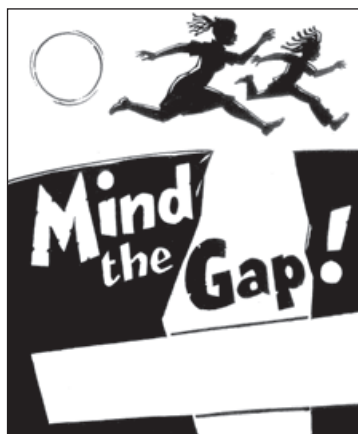

This content may not be sold or used for commercial purposes.

Curriculum and Assessment Policy Statement (CAPS) Grade 12

Mind the Gap study guide for Mathematics

ISBN 978-1-4315-1935-4

This publication has a **Creative Commons Attribution NonCommercial Sharealike license**. You can use, modify, upload, download, and share content, but you must acknowledge the Department of Basic Education, the authors and contributors. If you make any changes to the content you must send the changes to the Department of Basic Education. This content may not be sold or used for commercial purposes. For more information about the terms of the license please see:

<http://creativecommons.org/licenses/by-nc-sa/3.0/>.

Copyright © Department of Basic Education 2015

222 Struben Street, Pretoria, South Africa

Contact person: Dr Patricia Watson

Email: watson.p@dbe.gov.za

Tel: (012) 357 4502

<http://www.education.gov.za>

Call Centre: 0800202933

The first edition, published in 2012, for the Revised National Curriculum Statement (RNCS) Grade 12 Mind the Gap study guides for Accounting, Economics, Geography and Life Sciences; the second edition, published in 2014, aligned these titles to the Curriculum and Assessment Policy Statement (CAPS) and added more titles to the series in 2015, including the CAPS Grade 12 **Mind the Gap study guide for Mathematics**.

ISBN 78-1-4315-1935-4

Mind the Gap team

Series managing editor: Dr Patricia Watson

Production co-ordinators: Lisa Treffry-Goatley and Radha Pillay

Production assistants: Nomathamsanqa Hlatshwayo and Motshabi Mondlane

Authors: Lynn Bowie, Ronald Peter Jacobs, Sue Jobson, Terrence Mongameli Mbusi, Sello Gert Motsoane, Nonhlanhla Rachel Mthembu, Ntshengedzeni Steven Muthige, Mpho Francis Phatlane, Josephina Mamaroke Phatlane, Peter Ketshepile Raadt, Percy Stephen Tebeila, Anita van Heerden and Carol Wyeth.

Expert readers: Prof Bruce Watson, Leonard Mudau and Karen van Niekerk

Proofreaders: John Ostrowick and Angela Thomas

Designers: Sonja McGonigle and Erika van Rooyen

Illustrators: Michele Dean, Vusi Malindi, Khosi Pholosa, John Ostrowick, Kenneth Tekane

Cover illustration: Alastair Findlay

Afrikaans Translation: Marga Vos

Onsite writers' workshop IT support: Wayne Cussons

Special thanks to Winning Teams, CEO Denzil Hollis, for the organisation's subject expertise and workshop support

Winning Teams board game facilitators: Mantse Khoza and Sue Jobson

Ministerial foreword

The Department of Basic Education (DBE) has pleasure in releasing the second edition of the *Mind the Gap* study guides for Grade 12 learners. These study guides continue the innovative and committed attempt by the DBE to improve the academic performance of Grade 12 candidates in the National Senior Certificate (NSC) examination.

The study guides have been written by teams of experts comprising teachers, examiners, moderators, subject advisors and coordinators. Research, which began in 2012, has shown that the *Mind the Gap* series has, without doubt, had a positive impact on grades. It is my fervent wish that the *Mind the Gap* study guides take us all closer to ensuring that no learner is left behind, especially as we celebrate 20 years of democracy.

The second edition of *Mind the Gap* is aligned to the 2014 Curriculum and Assessment Policy Statement (CAPS). This means that the writers have considered the National Policy pertaining to the programme, promotion requirements and protocols for assessment of the National Curriculum Statement for Grade 12 in 2014.

The CAPS aligned *Mind the Gap* study guides take their brief in part from the 2013 National Diagnostic report on learner performance and draw on the Grade 12 Examination Guidelines. Each of the *Mind the Gap* study guides defines key terminology and offers simple explanations and examples of the types of questions learners can expect to be asked in an exam. Marking memoranda are included to assist learners to build their understanding. Learners are also referred to specific questions from past national exam papers and examination memos that are available on the Department's website – www.education.gov.za.

The CAPS editions include Accounting, Economics, Geography, Life Sciences, Mathematics, Mathematical Literacy and Physical Sciences Part 1: Physics and Part 2: Chemistry. The series is produced in both English and Afrikaans. There are also nine English First Additional Language (EFAL) study guides. These include EFAL Paper 1 (Language in Context); EFAL Paper 3 (Writing) and a guide for each of the Grade 12 prescribed literature set works included in Paper 2. These are Short Stories, Poetry, *To Kill a Mockingbird*, *A Grain of Wheat*, *Lord of the Flies*, *Nothing but the Truth* and *Romeo and Juliet*. (Please remember when preparing for EFAL Paper 2 that you need only study the set works you did in your EFAL class at school.)

The study guides have been designed to assist those learners who have been underperforming due to a lack of exposure to the content requirements of the curriculum and aim to mind-the-gap between failing and passing, by bridging the gap in learners' understanding of commonly tested concepts, thus helping candidates to pass.

All that is now required is for our Grade 12 learners to put in the hours required to prepare for the examinations. Learners, make us proud – study hard. We wish each and every one of you good luck for your Grade 12 examinations.

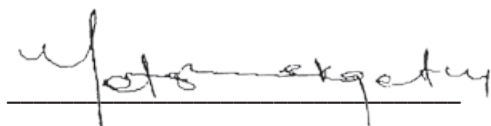

Matsie Angelina Motshekga, MP
Minister of Basic Education
2015



Matsie Angelina Motshekga, MP
Minister of Basic Education

Table of contents

Dear Grade 12 learner	ix
How to use this study guide	xi
Top 10 study tips	xii
Mnemonics.....	xiii
Mind maps.....	xiv
On the day of the exam	xv
Question words to help you answer questions.....	xvi
Vocabulary.....	xvii
General terms	xvii
Technical terms.....	xix
The maths you need.....	xxviii
Unit 1: Exponents and surds	1
1.1 The number system.....	1
1.2 Working with irrational numbers	3
1.3 Exponents	6
1.4 Exponential equations.....	12
1.5 Equations with rational exponents.....	14
1.6 Exam type examples.....	17
Unit 2: Algebra	19
2.1 Algebraic expressions.....	19
2.2 Addition and subtraction.....	19
2.3 Multiplication and division.....	20
2.4 Factorising.....	21
2.5 Notes on factorising a trinomial	22
2.6 Quadratic equations.....	24
2.7 Quadratic inequalities	30
2.8 Simultaneous equations.....	34
2.9 The nature of the roots.....	37
Unit 3: Number patterns, sequences and series	42
3.1 Number patterns	42
3.2 Arithmetic sequences.....	43
3.3 Quadratic sequences	45
3.4 Geometric sequences	48
3.5 Arithmetic and geometric series.....	50

Unit 4: Functions	60
4.1 What is a function?.....	60
4.2 Function notation.....	62
4.3 The basic functions, formulas and graphs	63
4.4 Inverse functions	81
4.5 The logarithmic function	84
Unit 5: Trig functions	88
5.1 Graphs of trigonometric functions.....	88
5.2 The effect of a on the shape of the graph: change in amplitude	91
5.3 The effect of q on the shape of the graph: vertical shift.....	93
5.4 The effect of b on the shape of the graph: change in period	94
5.5 The effect of p on the shape of the graph: horizontal shift	95
Unit 6: Finance growth and decay	101
6.1 Revision: Simple and compound interest	101
6.2 Calculating the value of P , i and n	104
6.3 Simple and compound decay formulae	107
6.4 Nominal and effective interest rates.....	109
6.5 Investments with time and interest rate changes.....	111
6.6 Annuities	113
Unit 7: Calculus	123
7.1 Average gradient.....	123
7.2 Average rate of change	125
7.3 The derivative of a function at a point	126
7.4 Uses of the derivative.....	131
7.5 Drawing the graph of a cubic polynomial.....	132
Unit 8: Probability	145
8.1 Revision	145
8.2 Theoretical probability and relative frequency	146
8.3 Venn diagrams	147
8.4 Mutually exclusive events	149
8.5 Complementary events	150
8.6 Events which are not mutually exclusive	152
8.7 Summary of symbols and sets used in probability	154
8.8 Tree diagrams and contingency tables	158
8.9 Contingency tables	161
8.10 Counting principles.....	164
8.11 Use of counting principles in probability.....	170

Unit 9: Analytical Geometry	172
9.1 Revise: Analytical Geometry.....	172
9.2 The equation of a line	177
9.3 The inclination of a line	179
9.4 Circles in analytical geometry.....	184
Unit 10: Trigonometry	191
10.1 Revise: Trig ratios.....	191
10.2 Trig ratios in all the quadrants of the Cartesian plane.....	194
10.3 Solving triangles with trig.....	196
10.4 Using a calculator to find trig ratios.....	197
10.5 The trig ratios of special angles.....	198
10.6 Using reduction formulae.....	201
10.7 Trigonometric identities.....	205
10.8 More trig identities	207
10.9 Solving trigonometric equations.....	209
10.10 More solving trig equations using identities.....	213
10.11 Compound and double angle identities.....	215
10.12 Determining x for which the identity is undefined	220
Unit 11: Trigonometry: Sine, cosine and area rules	222
11.1 Right-angled triangles	222
11.2 Area rule.....	224
11.3 Sine rule.....	226
11.4 Cosine rule	228
11.5 Problems in two and three dimensions	230
Unit 12: Euclidean Geometry.....	235
12.1 Revise: Proportion and area of triangles	235
12.2 Proportion theorems	237
12.3 Similar polygons	240
Unit 13: Statistics	248
13.1 Bar graphs and frequency tables	249
13.2 Measures of central tendency	250
13.3 Measures of dispersion (or spread)	254
13.4 Five number summary and box and whisker plot	256
13.5 Histograms and frequency polygons.....	260
13.6 Cumulative frequency tables and graphs (ogives)	263
13.7 Variance and standard deviation.....	267
13.8 Bivariate data and the scatter plot (scatter graph).....	271
13.9 The linear regression line (or the least squares regression line)	274

Dear Grade 12 learner

This *Mind the Gap* study guide helps you to prepare for the end-of-year CAPS Grade 12 exam.

The study guide does NOT cover the entire curriculum, but it does focus on core content of each knowledge area and points out where you can earn easy marks.

You must work your way through this study guide to improve your understanding, identify your areas of weakness and correct your own mistakes.

To ensure a good pass, you should also cover the remaining sections of the curriculum using other textbooks and your class notes.



Overview of the Grade 12 exam

The following topics make up each of the TWO exam papers that you write at the end of the year:

Paper	Topics	Duration	Total	Date	Marking
1	Patterns and sequences Finance, growth and decay Functions and graphs Algebra, equations and inequalities Differential Calculus Probability	3 hours	150	October/ November	Externally
2	Euclidean Geometry Analytical Geometry Statistics and regression Trigonometry	3 hours	150	October/ November	Externally

Cognitive level	Description of skills to be demonstrated	Weighting	Approximate number of marks in a 150-mark paper
Knowledge	<ul style="list-style-type: none"> • Recall • Identification of correct formula on the information sheet (no changing of the subject) • Use of mathematical facts • Appropriate use of mathematical vocabulary • Algorithms • Estimation and appropriate rounding of numbers 	20%	30 marks
Routine Procedures	<ul style="list-style-type: none"> • Proofs of prescribed theorems and derivation of formulae • Perform well-known procedures • Simple applications and calculations which might involve few steps • Derivation from given information may be involved • Identification and use (after changing the subject) of correct formula • Generally similar to those encountered in class 	35%	52–53 marks
Complex Procedures	<ul style="list-style-type: none"> • Problems involve complex calculations and/or higher order reasoning • There is often not an obvious route to the solution • Problems need not be based on a real world context • Could involve making significant connections between different representations • Require conceptual understanding • Learners are expected to solve problems by integrating different topics. 	30%	45 marks
Problem Solving	<ul style="list-style-type: none"> • Non-routine problems (which are not necessarily difficult) • Problems are mainly unfamiliar • Higher order reasoning and processes are involved • Might require the ability to break the problem down into its constituent parts • Interpreting and extrapolating from solutions obtained by solving problems based in unfamiliar contexts. 	15%	22–23 marks







How to use this study guide

This study guide covers selected parts of the different topics of the CAPS Grade 12 curriculum in the order they are usually taught during the year. The selected parts of each topic are presented in the following way:

- An explanation of terms and concepts;
- Worked examples to explain and demonstrate;
- Activities with questions for you to answer; and
- Answers for you to use to check your own work.

Look out for these icons in the study guide.



	Pay special attention		Hints to help you remember a concept or guide you in solving problems		Worked examples
	Step-by-step instructions		Refers you to the exemplar paper		Activities with questions for you to answer

- The activities are based on exam-type questions. Cover the answers provided and do each activity on your own. Then check your answers. Reward yourself for things you get right. If you get any incorrect answers, make sure you understand where you went wrong before moving on to the next section.
- In these introduction pages, we will go through the mathematics that you need to know, in particular, algebra and graphs. These are crucial skills that you will need for any subject that makes use of mathematics. Make sure you understand these pages before you go any further.
- Go to www.education.gov.za to download past exam papers for you to practice.

Use this study guide as a workbook. Make notes, draw pictures and highlight important concepts.



Top 10 study tips



- 1.** Have all your materials ready before you begin studying – pencils, pens, highlighters, paper, etc.
- 2.** Be positive. Make sure your brain holds on to the information you are learning by reminding yourself how important it is to remember the work and get the marks.
- 3.** Take a walk outside. A change of scenery will stimulate your learning. You'll be surprised at how much more you take in after being outside in the fresh air.
- 4.** Break up your learning sections into manageable parts. Trying to learn too much at one time will only result in a tired, unfocused and anxious brain.
- 5.** Keep your study sessions short but effective and reward yourself with short, constructive breaks.
- 6.** Teach your concepts to anyone who will listen. It might feel strange at first, but it is definitely worth reading your revision notes aloud.
- 7.** Your brain learns well with colours and pictures. Try to use them whenever you can.
- 8.** Be confident with the learning areas you know well and focus your brain energy on the sections that you find more difficult to take in.
- 9.** Repetition is the key to retaining information you have to learn. Keep going – don't give up!
- 10.** Sleeping at least 8 hours every night, eating properly and drinking plenty of water are all important things you need to do for your brain. Studying for exams is like strenuous exercise, so you must be physically prepared.

If you can't explain it simply, you don't understand it well enough.

Albert Einstein

Mnemonics

A mnemonic code is a useful technique for learning information that is difficult to remember.

Here's the most useful mnemonic for Mathematics, Mathematical Literacy and Physical Science:

BODMAS:

B – Brackets

O – Of or Orders: powers, roots, etc.

D – Division

M – Multiplication

A – Addition

S – Subtraction

Mnemonics encode information and make it easier to remember



Throughout the book you will be given other mnemonics to help you remember information.

The more creative you are and the more you link your 'codes' to familiar things, the more helpful your mnemonics will be.

Education helps one cease being intimidated by strange situations.

Maya Angelou

Mind maps

There are several mind maps included in the Mind the Gaps guides, summarising some of the sections.

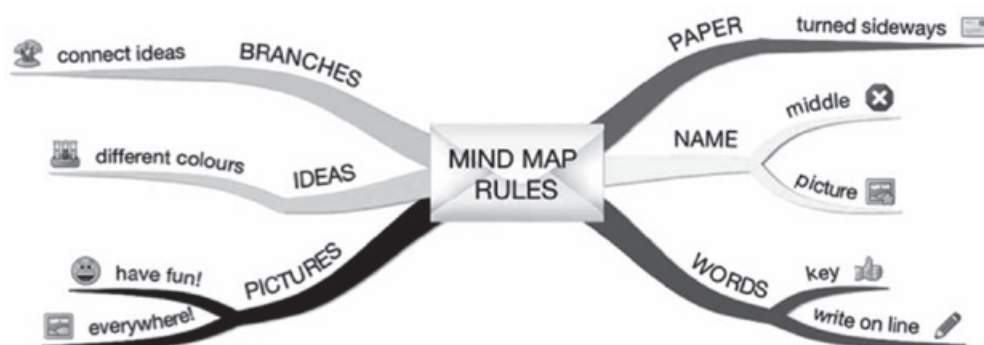

Mind maps work because they show information that we have to learn in the same way that our brains ‘see’ information.

As you study the mind maps in the guide, add pictures to each of the branches to help you remember the content.

You can make your own mind maps as you finish each section.

How to make your own mind maps:

1. Turn your paper sideways so your brain has space to spread out in all directions.
2. Decide on a name for your mind map that summarises the information you are going to put on it.
3. Write the name in the middle and draw a circle, bubble or picture around it.
4. Write only key words on your branches, not whole sentences. Keep it short and simple.
5. Each branch should show a different idea. Use a different colour for each idea. Connect the information that belongs together. This will help build your understanding of the learning areas.
6. Have fun adding pictures wherever you can. It does not matter if you can’t draw well.

Mind mapping your notes makes them more interesting and easier to remember.

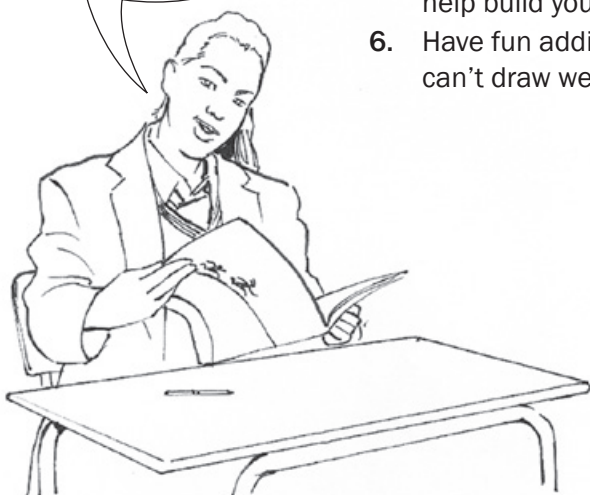

On the day of the exam

- 1.** Make sure you have all the necessary stationery for your exam, i.e. pens, pencils, eraser, protractor, compass, calculator (with new batteries). Make sure you bring your ID document and examination admission letter.
- 2.** Arrive on time, at least one hour before the start of the exam.
- 3.** Go to the toilet before entering the exam room. You don't want to waste valuable time going to the toilet during the exam.
- 4.** Use the 10 minutes reading time to read the instructions carefully. This helps to 'open' the information in your brain. Start with the question you think is the easiest to get the flow going.
- 5.** Break the questions down to make sure you understand what is being asked. If you don't answer the question properly you won't get any marks for it. Look for the key words in the question to know how to answer it. Lists of difficult words (vocabulary) is given a bit later on in this introduction.
- 6.** Try all the questions. Each question has some easy marks in it so make sure that you do all the questions in the exam.
- 7.** Never panic, even if the question seems difficult at first. It will be linked with something you have covered. Find the connection.
- 8.** Manage your time properly. Don't waste time on questions you are unsure of. Move on and come back if time allows. Do the questions that you know the answers for, first.
- 9.** Write big and bold and clearly. You will get more marks if the marker can read your answer clearly.
- 10.** Check weighting – how many marks have been allocated for your answer? Take note of the ticks in this study guide as examples of marks allocated. Do not give more or less information than is required.



Question words to help you answer questions

It is important to look for the question words (the words that tell you what to do) to correctly understand what the examiner is asking. Use the words in the table below as a guide when answering questions.

Question word/phrase	What is required of you
Analyse	Separate, examine and interpret
Calculate	This means a numerical answer is required – in general, you should show your working, especially where two or more steps are involved
Classify	Group things based on common characteristics
Compare	Point out or show both similarities and differences between things, concepts or phenomena
Define	Give a clear meaning
Describe	State in words (using diagrams where appropriate) the main points of a structure/process/phenomenon/investigation
Determine	To calculate something, or to discover the answer by examining evidence
Differentiate	Use differences to qualify categories
Discuss	Consider all information and reach a conclusion
Explain	Make clear; interpret and spell out
Identify	Name the essential characteristics PAY SPECIAL ATTENTION
Label	Identify on a diagram or drawing
List	Write a list of items, with no additional detail
Mention	Refer to relevant points
Name	Give the name (proper noun) of something
State	Write down information without discussion
Suggest	Offer an explanation or a solution
Tabulate	Draw a table and indicate the answers as direct pairs

*In every exam question, put a **CIRCLE** around the question word and underline any other important key words. These words tell you exactly what is being asked.*



Vocabulary

The following vocabulary consists of all the difficult words used in Mind the Gap Mathematics, Mathematical Literacy, and Physical Science. We suggest that you read over the list below a few times and make sure that you understand each term. Tick next to each term once you understand it so you can see easily where the gaps are in your knowledge.

KEY

Abbreviation	Meaning
(v)	verb: doing-word or action word, such as “walk”
(n)	noun: naming word, such as “person”
(adj)	adjective: describing word such as “big”
(adv)	adverb: describing word for verbs, such as “fast”
(prep)	preposition: a word describing a position, such as “on”, “at”
(sing)	singular: one of
(pl)	plural: more than one of
(abbr)	abbreviation

General terms

Term	Meaning
A	
abbreviate	(v). Make shorter.
account for	(v). Explain why.
adjacent	(adj). Next to something.
analyse	(v). Examine something in detail.
annotated	(adj). Something that has comments or explanations, usually written, added to it.
apply	(v). Make a formal application; be relevant to; work hard; place on.
approximate	(v. & adj.). Come close to (v); roughly, almost, not perfectly accurate, close but not exact. The verb is pronounced “approximayt” and the adjective is pronounced “approximitt”.
ascending	(adj). Going up.
arbitrary	(adj). Based on random choice; unrestrained and autocratic.

C	
category	(n). Class or group of things.
complex	(adj). Consisting of many different parts; not easy to understand (n). a group or system of things connected in a complicated way.
component	(n). A part.
compose	(v). To make up from parts.
composite	(n). Something made up of parts; (adj). made up of several parts.
conjunction	(n). When two or more things come together at the same point; in grammar, a part of speech that connects words, sentences, phrases or clauses, e.g.: “and”
consecutive	(adj). One after another without any gaps or breaks.
consider	(v). think about.
contrast	(v). Show the difference between; (n). something that is very different from what it is being compared with.
conversely	(adv). The opposite of.
D	
data (pl), datum (sing)	(n). Information given or found.
deduce	(v). To work something out by reasoning.
deduction	(n). Conclusion or idea that someone has worked out.
define	(v). Give the meaning of a word or words.
definition	(n). The meaning of a word or words.
denote	(v). To refer to or mean something.
descending	(adj). Going down.
determine	(v). Work out, usually by experiment or calculation.
discreet	(adj). Careful, polite.
discrete	(adj). Single, separate, distinct, a part.
E	
establish	(v). Show or prove, set up or create.
exceed	(v). Go beyond.
excess	(n). More than necessary.

excluding	(prep). Not including.
exclusive	(adj). Excluding or not admitting other things; reserved for one particular group or person.
exemplar	(n). A good or typical example.
exempt	(v). To free from a duty.
exempt	(adj). Be freed from a duty.
exemption	(n). Being freed from an obligation.
exhibit	(v). To show or display.
exhibit	(n). A part of an exhibition.
extent	(n). The area covered by something. Limit.
F	
factor	(n). A circumstance, fact or influence that contributes to a result; a component or part. A number that is divisible into another number without a remainder.
factory	(n). A place where goods are made or put together from parts.
find	(v). Discover or locate.
find	(n). Results of a search or discovery.
finding	(n). Information discovered as the result of an inquiry.
format	(n). Layout or pattern; the way something is laid out.
H	
horizontal	(adj). Across, from left to right or right to left. (From “horizon”, the line dividing the earth and the sky).
hypothesis	(n). A theory or proposed explanation.
hypothetical	(adj). Theoretical or tentative; waiting for further evidence.
I	
identify	(v). Recognise or point out.
illustrate	(v). Give an example to show what is meant; draw.
imply	(v). Suggest without directly saying what is meant.
indicate	(v). Point out or show.
initial	(n). First.
insufficient	(adj). Not enough.

inter-changeable	(adj). Can be swapped or exchanged for each other.
investigate	(v). Carry out research or a study.
M	
magnitude	(adj). Size.
manipulate	(v). Handle or control (a thing or a person).
motivate	(v). Give someone a reason for doing something.
multiple	(adj). Many.
N	
negligible	(adj). Small and insignificant; can be ignored. From “neglect” (ignore).
numerical	(adj). Relating to or expressed as a number or numbers.
numerous	(adj). Many.
O	
obtain	(v). Get.
optimal	(adj). Best; most favourable.
optimum	(adj). Best; (n) the most favourable situation for growth or success.
P	
provide	(v). Make available for use; supply.
R	
reciprocal	(adj). Given or done in return.
record	(v). Make a note of something in order to refer to it later (pronounced ree-cord).
record	(n). A note made in order to refer to it later; evidence of something; a copy of something (pronounced rec-cord).
relative	(adj). Considered in relation to something else; compared to.
relative	(n). A family member.
represent	(v). Be appointed to act or speak for someone; amount to.
resolve	(v). Finalise something or make it clear; bring something to a conclusion.

respect	(v). Admire something or someone; consider the needs or feelings of another person.
respectively	(adj). In regards to each other, in relation to items listed in the same order.
S	
simultaneously	(adv). At the same time.
suffice	(v). Be enough.
surplus	(adj). More than is needed.
survey	(n). A general view, examination, or description of someone or something.
survey	(v). Look closely at or examine; consider a wide range of opinions or options.
T	
tendency	(n). An inclination to do something in a particular way; a habit.
transverse	(adj). Extending across something.
V	
verify	(v). Show to be true; check for truth; confirm.
vice versa	(adv). The other way round.
versus	(prep). Against. Abbreviated “vs” and sometimes “v”.
vertical	(adj). Upright; straight up; standing.

Technical terms

A	
abscissa	(n). The distance from a point to the vertical or y-axis, measured parallel to the horizontal or x-axis; the x-coordinate. See ordinate.
acute	(adj). Having an angle less than 90°.
algebra	(n). A mathematical system where unknown quantities are represented by letters, which can be used to perform complex calculations through certain rules.
altitude	(n). Height.

angel	(n). In Abrahamic religions, a messenger from God. Note the spelling.
angle	(n). The difference in position between two straight lines which meet at a point, measured in degrees. Note the spelling.
annual	(adj). Once every year. (E.g. “Christmas is an annual holiday”).
annum, per	(adv). For the entire year. (E.g. “You should pay R 100 per annum”).
annuity	(n). A fixed sum of money paid to someone each year, typically for the rest of their life, as an insurance policy. See policy.
apex	(n). The tip of a triangle or two lines meeting.
approach	(v). To approximate or come close to in value.
area	(n). Length x breadth (width). In common usage: a place.
asymptote	(n). A line that continually approaches a given curve but does not meet it at any finite distance.
average	(n). Mathematics: The sum of parts divided by the quantity of parts. In common use: neither very good, strong, etc., but also neither very weak, bad, etc; the middle. If you are asked to find the average, you always have to calculate it using the information you have. For example, the average of (1;2;3) is 2, because $(1+2+3)/3 = 2$. See also mean, median and mode.
axiom	A basic truth of mathematics.
axis (sing), axes (pl, pronounced “akseez”)	(n). A line along which points can be plotted (placed), showing how far they are from a central point, called the origin. See origin. “Vertical axis” or “y-axis” refers to how high up a point is above the origin (or how far below). “Horizontal axis” or “x-axis” refers to how far left or right a point is away from the origin.
B	
base	(n). The horizontal lowest line on a diagram of a geometrical shape, usually of a triangle. Or: a number used as the basis of a numeration scale. Or: a number in terms of which other numbers are expressed as logarithms.

bias	(n). To be inclined against something or usually unfairly opposed to something; to not accurately report on something; to favour something excessively.
binomial	(n). An algebraic expression of the sum or the difference of two terms.
bisect	(v). To cut into two.
bivariate	(adj). Depending on two variables.
breadth	(n). How wide something is. From the word “broad”.
C	
calculus	(n). A branch of mathematics that deals with the finding and properties of derivatives and integrals of functions, by methods originally based on the summation of infinitesimal (infinitely small) differences. The two main types are differential calculus and integral calculus.
cancel	(v). To remove a factor by dividing by the factor.
chance	(n). The same as possibility or likelihood; that something might happen but that it is hard to predict whether it will.
chart	(v). To draw a diagram comparing values on Cartesian axes.
chord	(n). A line cutting across a circle or arc at a position other than the diameter. Note spelling.
circumference	(n). The distance around the outer rim of a circle.
coefficient	(n). A constant value placed next to an algebraic symbol as a multiplier. Same as constant (see below). Or: a multiplier or factor that measures a property, e.g. coefficient of friction.
complement	(n). Geometry: the amount in degrees by which a given angle is less than 90° . Mathematics: the members of a set or class that are not members of a given subset. Do not confuse with compliment (praise).
composite	(adj). Made of parts.
compound interest	(n). Interest charged on an amount due, but including interest charges to date. Compare to simple interest.
constant	(n). See coefficient. Means “unchanging”.

consecutive	(adj). Following on from one another.
continuous	(adj). Mathematics: having no breaks between mathematical points; an unbroken graph or curve represents a continuous function. See function.
control	(n. and v.). To ensure something does not change without being allowed to do so (v); an experimental situation to which nothing is done, in order to compare to a separate experimental situation, called the ‘experiment’, in which a change is attempted. The control is then compared to the experiment to see if a change happened.
control variable	(n). A variable that is held constant in order to discover the relationship between two other variables. “Control variable” must not be confused with “controlled variable” (see independent variable).
coordinate	(n). The x or y location of a point on a Cartesian graph, given as an x or y value. Coordinates (pl) are given as an ordered pair (x, y).
correlate	(v). To see or observe a relationship between two things, without showing that one causes the other.
correlation	(n). That there is a relationship between two things, without showing that one causes the other.
correspond	(v). To pair things off in a correlational relationship. For two things to agree or match. E.g. A corresponds to 1, B corresponds to 2, C corresponds to 3, etc.
cubed	(adj). The power of three; multiplied by itself three times.
cubic	(adj). Shaped like a cube; having been multiplied by itself three times.
cut	(n). A subdivision of a line or point where one line crosses over another.
cyclic	(adj). Pertaining to a circle.
cylinder	(n). A tall shape with parallel sides and a circular cross-section – think of a log of wood, for example, or a tube. See parallel. The formula for the volume of a cylinder is $\pi r^2 h$.

D	
dependent (variable)	(adj/n). A variable whose value depends on another; the thing that comes out of an experiment, the effect; the results. See also independent variable and control variable. The dependent variable has values that depend on the independent variable, and we plot it on the vertical axis.
derivation	(n). Mathematics: to show the working of your arithmetic or answer or solution; the process of finding a derivative.
derivative	(n). Mathematics: The rate of change of a function with respect to an independent variable. See independent variable. In common use: something that comes from something else.
determine(s) (causation)	(v). To cause; to ensure that; to set up so that; to find out the cause of.
deviation	(n). A variation from a statistical norm; not as far out as an outlier. An amount by which a single measurement differs from a fixed value such as the mean. A significant deviation from the average value.
di-	(prefix). Two.
diagonal	(adj. & n.). A line joining two opposite corners of an angular shape.
diameter	(n). The line passing through the centre of a shape from one side of the shape to the other, esp. a circle. Formula: $d = 2r$. See radius, radii, circumference.
difference	(n). Mathematics: subtraction. Informally: a dissimilarity. How things are not the same.
digit	(n). A number represented in writing.
dimension	(n). The measurable size or extent of usually a geometric shape and often on a Cartesian Coordinate system, e.g. the x-dimension (breadth).
discriminant	(n). A function of the coefficients of a polynomial equation whose value gives information about the roots of the polynomial.
distribution	(n). How something is spread out. Mathematics: the range and variety of numbers as shown on a graph.

divisor	(n). The number below the line in a fraction; the number that is dividing the other number above the fraction line. See numerator, denominator.
domain	(n). The possible range of x-values for a graph of a function. See range.
E	
element	(n). Mathematics: part of a set of numbers. Popular use: part of.
eliminate	(v). To remove from an equation. See cancel.
equiangular	(adj). Having the same angle.
equidistant	(adj). Having the same distance or length.
equilateral	(adj). Having sides of the same length.
estimate	(n., v.). To give an approximate value close to an actual value; an imprecise calculation.
Euclidean	(adj). Pertaining to geometry of straight lines on flat planes.
even	(adj). Divisible by two without a remainder.
exponent	(n). When a number is raised to a power, i.e. multiplied by itself as many times as shown in the power (the small number up above the base number). So, 2^3 means $2 \times 2 \times 2$. See also cubed.
exponential	(adj). To multiply something many times; a curve representing an exponent.
expression	(n). A formula or equation.
extrapolation	(n). To extend the line of a graph further, into values not empirically documented, to project a future event or result. In plain language: to say what is going to happen based on past results which were obtained (gotten) by experiment and measurement. If you have a graph and have documented certain results (e.g. change vs time), and you draw the line further in the same curve, to say what future results you will get, that is called 'extrapolation'. See predict. Mathematics: to project another iteration, value or solution, based on a formula that covers or formulates a previous solution.

F	
factorial	(n). The product of an integer and all the integers below it; e.g. factorial four (4!) is equal to 24.
factorise	(v). To break up into factors.
formula	(n). See expression.
fraction	(n). Mathematics: Not a whole number; a representation of a division. A part. E.g. the third fraction of two is 0,666 or $\frac{2}{3}$ meaning two divided into three parts.
frequency	(n). How often. Usually represented as a fraction, e.g. $\frac{12}{48} = \frac{1}{4}$ or 0,25.
function	(n). Mathematics: when two attributes or quantities correlate. If y changes as x changes, then $y = f(x)$. See correlate, graph, Cartesian, axis, coordinate. Also: a relation with more than one variable (mathematics).
G	
geometric	(adj). Progressing or growing in a regular ratio.
geometry	(n). The mathematics of shape.
gradient	(n). A slope. An increase or decrease in a property or measurement. Also the rate of such a change. In the formula for a line graph, $y=mx+c$, m is the gradient.
gradually	(adv). To change or move slowly.
graph	(n). A diagram representing experimental or mathematical values or results. Cartesian Coordinates.
graphic	(n., adj.). A diagram or graph (n). Popular use: vivid or clear or remarkable (adj.).
graphically	(adv). Using a diagram or graph. Popular use: to explain very clearly.
H	
histogram	(n). A bar graph that represents continuous (unbroken) data (i.e. data with no gaps). There are no spaces between the bars. A histogram shows the frequency, or the number of times, something happens within a specific interval or “group” or “batch” of information.

homologous	(n). Belonging to the same group of things; analogous.
hyperbola	(n). Mathematics: a graph of a section of a cone with ends going off the graph; a symmetrical (both sides the same) open curve.
hypotenuse	(n). The longest side of a right-angled triangle.
I	
illuminate	(v). To explain or light up.
incline	(n. & v.). Slope. See gradient (n); to lean (v).
independent (variable)	(n). The things that act as input to the experiment, the potential causes. Also called the controlled variable. The independent variable is not changed by other factors, and we plot it on the horizontal axis. See control, dependent variable.
inequality	(n). A relation between two expressions that are not equal, employing a sign such as \neq ‘not equal to’, $>$ ‘greater than’, or $<$ ‘less than’.
inflation	(n). That prices increase over time; that the value of money decreases over time. General use: the action of getting bigger.
insufficient	(adj). Not enough.
integer	(n.) a whole number not a fraction, can be negative.
intercept	(n.) Where a line cuts an axis on a graph. See cut.
interest	(n). Finance: money paid regularly at a particular rate for the use or loan of money. It can be paid by a finance organisation or bank to you (in the case of savings), or it may be payable by you to a finance organisation on money you borrowed from the organisation. See compound interest and simple interest, see also borrow.
interquartile	(adj). Between quartiles. See quartile.
intersection	(n). Where two groups overlap on a Venn Diagram.
interval	(n). Gap. A difference between two measurements.
inverse	(n). The opposite of. Mathematics: one divided by. E.g. $\frac{1}{2}$ is the inverse of 2.

imaginary numbers	(n). I; a number which is a multiple of the square root of (-1) . The opposite of real numbers. Not examinable/advanced.
irrational numbers	(n). Fractions which recur, or which cannot be expressed as a ratio of whole numbers. Decimals.
isosceles (triangle)	(n., adj.). A triangle with two sides of equal length.
L	
law	(n). A formula or statement, deduced (discovered) from prior axioms (truths), used to predict a result.
likely	(adj). To be probable; something that might well happen.
linear	(adj). In a line. Mathematics: in a direct relationship, which, when graphed with Cartesian coordinates, turns out to be a straight line.
logarithm	(n). A quantity representing the power by which a fixed number (the base) must be raised to produce a given number. The base of a common logarithm is 10, and that of a natural logarithm is the number e (2,7183...). A log graph can turn a geometric or exponential relationship, which is normally curved, into a straight line.
M	
magnitude	(n). Size.
manipulate	(v). To change, or rearrange something. Usually in Mathematics it means to rearrange a formula to solve for (to get) an answer.
mean	(n). See average.
median	(n). Mathematics: the number in the middle of a range of numbers written out in a line or sequence.
metric	(adj). A measurement system, using a base of 10 (i.e. all the units are divisible by 10). The USA uses something known as the Imperial system, which is not used in science. The Imperial system is based on 12. Examples: 2,54 cm (metric) = 1 inch (imperial). 1 foot = 12 inches = approx. 30 cm; 1 metre = 100 cm. 1 Fl.Oz (fluid ounce) = approx 30 mℓ.

minimise	(v). To make as small as possible.
minimum	(n). The smallest amount possible.
modal	(adj). Pertaining to the mode, or method. Can mean: about the mathematical mode or about the method used. See mode.
mode	(n). the most common number in a series of numbers. See also mean, median.
model	(n). A general or simplified way to describe an ideal situation, in science, a mathematical description that covers all cases of the type of thing being observed. A representation.
mutually	(adj). In respect to each other, affecting each other.
N	
natural numbers	(n). Any number which is not a fraction and greater than -1 (includes zero). Positive whole numbers.
negative	(adj). Below zero.
normal	(n., adj.). Mathematics and Physics: a force, vector or line that acts at right angles to another force, vector or line or object. (n). Common use: Regular or standard (adj).
numerator	(n). The opposite of a denominator; the number on top in a fraction.
O	
obtuse	(adj). Having an angle greater than 90° but less than 180° .
odd	(adj). Not divisible by two without a remainder.
ogive	(adj). A pointed arch shape; a cumulative frequency graph.
optimal	(adj). Best, most.
ordinate	(n). A straight line from any point drawn parallel to one coordinate axis and meeting the other, especially a coordinate measured parallel to the vertical. See abscissa.
origin	(n). Mathematics: the centre of a Cartesian coordinate system. General use: the source of anything, where it comes from.

outlier	(n). Statistics: a data point which lies well outside the range of related or nearby data points.
P	
parallel	(adj). Keeping an equal distance along a length to another item (line, object, figure). Mathematics: two lines running alongside each other which always keep an equal distance between them.
parallelogram	(n). Any four-sided figure with two sides parallel. Abbr.: parm.
parameter	(n). A value or algebraic symbol in a formula. Statistics: a numerical characteristic of a population, as distinct from a statistic of a sample. A quantity whose value is selected for the particular circumstances and in relation to which other variable quantities may be expressed.
particular	(adj). A specific thing being pointed out or discussed; to single out or point out a member of a group.
pent-	(prefix). Five.
pentagon	(n). A five sided figure with all sides equal in length.
per	(prep). For every, in accordance with.
per annum	(adv). Once per year; for each year.
percent	(adv). For every part in 100. The rate per hundred.
percentile	(n). A division of percentages into subsections, e.g. if the scale is divided into four, the fourth percentile is anything between 75 and 100%.
perimeter	(n). The length of the outer edge; the outer edge of a shape.
period	(n). The time gap between events; a section of time.
periodic	(adj). Regular; happening regularly.
permutation	(n). The action of changing the arrangement, especially the linear order, of a set of items.
perpendicular	(adj). Normal; at right angles to (90°).

pi	(n). π , the Greek letter p, the ratio of the circumference of a circle to its diameter. A constant without units, value approximately 3,14159.
plan	(n). Architecture: a diagram representing the layout and structure of a building, specifically as viewed from above. More general use: any design or diagram, or any intended sequence of actions, intended to achieve a goal.
plane	(n). A flat surface.
plot	(v). To place points on a Cartesian coordinate system; to draw a graph.
poly-	(prefix). Many.
polygon	(n). Any shape with many (at least three) equal sides and angles.
polyhedron	(n). A three-dimensional shape with many usually identical flat sides.
polynomial	(n). An expression of more than two algebraic terms, especially the sum of several terms that contain different powers of the same variable(s).
population	(n). Statistics: the larger body from which the statistical sample is taken.
positive	(adj) Above zero.
predict	(v). General use: to foresee. Physical Science: to state what will happen, based on a law. See law.
prime number	(n). Any number divisible only by one and itself.
probability	(n). How likely something is. See likely. Probability is generally a mathematical measure given as a decimal, e.g. [0] means unlikely, but [1,0] means certain, and [0,5] means just as likely versus unlikely. [0,3] is unlikely, and [0,7] is quite likely. The most common way to express probability is as a frequency, or how often something comes up. E.g. an Ace is $\frac{1}{13}$ or 0,077 likely, in a deck of cards, because there are 4 of them in a set of 52 cards.

product	(n). Mathematics: the result of multiplying two numbers.
project	(n. & v.). A project (n., pronounced PRODJ-ekt) is a plan of action or long-term activity intended to produce something or reach a goal. To project (v., pronounced prodj-EKT), is to throw something, or to guess or predict (a projection). To project a result means to predict a result. See extrapolate.
proportion	(n). To relate to something else in a regular way, to be a part of something in relation to its volume, size, etc; to change as something else changes. See correlate and respectively.
pyramid	(n). A polyhedron of which one face is a polygon of any number of sides, and the other faces are triangles with a common vertex.
Pythagoras's Theorem	(n). The square on the hypotenuse is equal to the sum of the squares on the other two sides of a right-angled triangle. Where h is the hypotenuse, a is the side adjacent to the right angle, and b is the other side: $h^2 = a^2 + b^2$.
Q	
quadrilateral	(n). A shape with four sides.
qualitative	(adj). Relating to the quality or properties of something. A qualitative analysis looks at changes in properties like colour, that can't be put into numbers. Often contrasted with quantitative.
quantitative	(adj). Relating to, or by comparison to, quantities. Often contrasted with qualitative. A quantitative analysis is one in which you compare numbers, values and measurements.
quantity	(n). Amount; how much.

quartile	(n). A quarter of a body of data represented as a percentage. This is the division of data into 4 equal parts of 25% each. To determine the quartiles, first divide the information into two equal parts to determine the median (Q2), then divide the first half into two equal parts, the median of the first half is the lower quartile (Q1), then divide the second half into two equal parts, and the median of the second half is the upper quartile (Q3). Data can be summarised using five values, called the five number summary, i.e. the minimum value, lower quartile, median, upper quartile, and maximum value.
quotient	(n). A ratio.
R	
radical	(n). A root.
radius (sing), radii (plur)	(n). The distance between the centre of an object, usually a circle, and its circumference or outer edge. Plural is pronounced "ray-dee-eye."
random	(n). Unpredictable, having no cause or no known cause. Done without planning.
range	(n). The set of values that can be supplied to a function. The set of possible y-values in a graph. See domain.
rate	(n). How often per second (or per any other time period). Physics: number of events per second; see frequency. Finance: the exchange rate or value of one currency when exchanged for another currency; how many units of one currency it takes to buy a unit of another currency. Also "interest rate", or what percentage of a loan consists of interest charges or fees.
ratio	(n). A fraction; how one number relates to another number; exact proportion. If there are five women for every four men, the ratio of women to men is 5:4, written with a colon (:). This ratio can be represented as the fraction $\frac{5}{4}$ or $1\frac{1}{4}$ or 1,25; or we can say that there are 25% more women than men.

rational numbers	(n). A fraction which can be expressed as a ratio of whole numbers. See irrational numbers.
ray	(n). A line from amongst a set of lines passing through the same central point. See radius.
reciprocal	(n). A complement of a number which when added to the number yields 1.0.
rectangle	(n). A parallelogram with only right angles (90°).
real number	(n). Any non-imaginary number, that is, a number not a multiple of the square root of (-1). Includes rational and irrational numbers, integers.
remainder	(n). Leftovers. Mathematics: an amount left over after division which cannot be divided further unless one wishes to have a decimal or fraction as a result, i.e. where the divisor does not exactly divide the numerator by an integer (whole number).
rhombus	(n). A quadrilateral (four sided) figure (diagram or shape) which has equal sides, but no right-angles (90° angles).
right angle	(n). An angle of 90° .
round	(v). To approximate, especially an irrational number, to a shorter series of decimals.
S	
scale	(n). A system of measurement, with regular intervals or gaps between units (subdivisions) of the scale.
scalene	(adj). A triangle with unequal sides.
simple interest	(n). Interest charged on the original amount due only, resulting in the same fee every time.
simplify	(v). To make simpler. Mathematics: to divide throughout by a common factor (number or algebraic letter) that will make the equation easier to read and calculate.
solution	(n). Mathematics: the step-by-step displaying of calculations to arrive at answers. Common use: the answer to a problem, in the sense of dissolving (removing) a problem.
solve	(v). To come up with a solution (answer). Show your working.

sphere	(n). A perfectly round three-dimensional shape. A ball.
square	(n). Mathematics: a shape or figure with four equal sides and only right angles; the exponent 2 (e.g. the square of 4 is $4^2 = 16$).
squared	(adj). Having been multiplied by itself, put to the exponent 2. See square.
statistics	(n). The mathematics of chance and probability.
steep	(adj). Having a large gradient.
subscript	(n). A number placed below the rest of the line, e.g. CO_2 .
substitute	(v). To replace.
substitution	(n). The process of substituting. Mathematics: to replace an algebraic symbol in a formula with a known value or another formula, so as to simplify the calculation. See simplify.
subtotal	(n). Finance: the total amount due on a statement or invoice, usually without VAT (tax) charges given. Or: a total for a section of an invoice or statement or series of accounts, but not the total of the whole invoice, statement or account.
successive	(adj). One after the other.
sum	(n., v.). To add things up. Represented by Greek Sigma (Σ): Σ or the plus sign (+).
superscript	(n). A number placed above the rest of the line, e.g. πr^2 .
surd	(n). An irrational root (e.g. $\sqrt{2}$).
T	
tally	(n). A total count; to count in fives by drawing four vertical lines then crossing through them with the fifth line.
tangent	(n). A straight line touching a curve only at one point, indicating the slope of the curve at that point; the trigonometric function of the ratio of the opposite side of a triangle to the adjacent side of a triangle in a right-angled triangle; a curve that goes off the chart.
tax	(n). A compulsory levy imposed on citizens' earnings or purchases to fund the activities of government.

taxable	(adj). A service, purchase or item or earning that has a tax applied to it.
tetra-	(prefix). Four. Same as quad.
theory	(n). A usually mathematical representation of an explanation for something in the sciences, which does not depend on the thing being explained.
theorem	(n). A general proposition not self-evident but proved by a chain of reasoning; a truth established by means of accepted truths. Compare to theory.
trapezium	(n). A quadrilateral with one pair of sides parallel (and the other sides usually having complementary angles).
treble	(adj). Triple.
trends	(n). Regular patterns within data.
tri-	(prefix). Three.
trigonometry	(n). The relationship and ratios between sides and angles within a right-angled triangle.
U	
unit	(n). A subdivision of a scale. See scale.
union	(adj). When two sets in a Venn Diagram overlap into one set.

V	
variable	(n., adj.). A letter used to represent an unknown quantity in algebra (n); a quantity that changes (n); subject to change (adj).
Venn Diagram	(n). A diagram representing sets (classes of objects) as circles.
vertex	(n). The angular point(s) of a polygon; apex. Plural: vertices.
volume	(n). A measure of the space occupied by an object, equal to length x breadth x height.
W	
whole number	(n). Any number not a fraction or decimal, greater than zero. Natural numbers and zero.
Y	
yard	(n). Old Imperial measurement of length, approximately equal to a metre (1,09 m).
yield	(n., v.). An answer or solution.

The maths you need

This section gives you the basic mathematical skills that you need to pass any subject that makes use of mathematics. Do not go any further in this book until you have mastered this section.

1. Basic Pointers

- If a formula does not have a multiplication (\times) sign or a dot-product (\cdot), and yet two symbols are next to each other, it means “times”. So, m_1m_2 means *mass 1 times mass 2*. You can also write it as $m_1 \times m_2$, or $m_1 \cdot m_2$
- Comma means the same as decimal point on your calculator (i.e. $4,5 = 4.5$). Do not confuse the decimal point with dot product (multiply): $4.5 = 4\frac{1}{2}$ but $4 \cdot 5 = 20$. Rather avoid using the dot product for this reason.
- A variable is something that varies (means: changes). So, for example, the weather is a variable in deciding whether to go to the shops. Variables in science and mathematics are represented with letters, sometimes called algebraic variables. The most common you see in maths is x , probably followed by y , z .

2. Subject of Formula or Solving For

Very often in mathematics you have to “make something the subject of a formula” or “solve for something”. This refers to finding the value of an unknown quantity if you have been given other quantities and a formula that shows the relationship between them.

The word ‘formula’ means a rule for working something out. We work with formulas to draw graphs and also to calculate values such as area, perimeter and volume. You are usually given the formulas in an exam question, so you don’t have to remember them, but you do need to select the right numbers to put into the formula (substitute). For example, the formula for the area of a triangle is

$$\text{Area} = \frac{1}{2} \text{base} \times \text{height}.$$

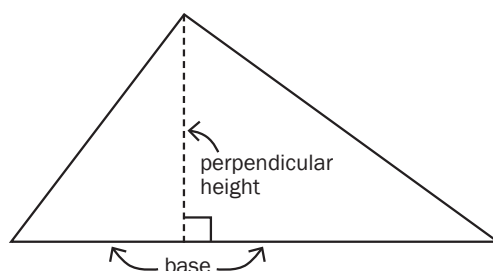

In this formula:

- the word *Area* stands for the size of the area of a triangle (the whole surface that the triangle covers)
- the word *base* stands for the length of the base of the triangle
- the word *height* stands for the length of the perpendicular height of the triangle.

A formula can be written in letters rather than words, for example:

$$A = \frac{1}{2} b \times h.$$

The quantity on its own on the left is called the subject of the formula.

e.g. 1

If John has 5 apples, and he gives some to Joanna, and he has two apples left, how many did he give to Joanna? Well, the formula would be something like this: $5 - x = 2$

To solve for x , we simply have to swap the x and the 2. What we're actually doing is adding " x " to both sides:

$$5 - x + x = 2 + x$$

this becomes: $5 = 2 + x$

then we subtract 2 from both sides to move the 2 over:

$$5 - 2 = 2 - 2 + x$$

$$5 - 2 = x$$

$$3 = x \quad \dots \text{ so John gave Joanna three apples.}$$

The same procedures apply no matter how complex the formula looks. Just either add, subtract, square, square root, multiply or divide throughout to move the items around.

e.g. 2

Let's take an example from Physical Science: $V = IR$. This means, the voltage in a circuit is equal to the current in the circuit times the resistance. Suppose we know the voltage is 12 V, and the resistance is 3 Ω . What is the current?

$$V = IR$$

$$12 = 3 \times I$$

divide throughout by 3 so as to isolate the I

$$\frac{12}{3} = \left(\frac{12}{3}\right) I$$

remember that anything divided by itself is 1, so:

$$\frac{12}{3} = (1) \times I \quad \dots \text{ and } \frac{12}{3} = 4 \quad \dots \text{ so}$$

$$4 = I \text{ or}$$

$$I = 4 \text{ A } \dots \text{ The circuit has a current of 4 amperes.}$$

e.g. 3

Here's a more tricky example from Physical Science. Given

$$K_c = 4,5$$

$$[\text{SO}_3] = 1,5 \text{ mol/dm}^3$$

$$[\text{SO}_2] = 0,5 \text{ mol/dm}^3$$

$$[\text{O}_2] = \frac{(x-48)}{64} \text{ mol/dm}^3$$

solve for x .

$$K_c = \frac{[\text{SO}_3]^2}{[\text{SO}_2]^2[\text{O}_2]} \quad \therefore 4,5 = \frac{(1,5)^2}{(0,5)^2 \frac{(x-48)}{64}}$$

$$\therefore x = 176 \text{ g}$$

How did we get that answer?



Step by Step

Let's see how it works.

First, solve for the exponents (powers):

$$4,5 = \frac{2,25}{(0,25)^{\frac{(x-48)}{64}}}$$

Now, we can see that 2,25 and 0,25 are similar numbers (multiples of five), so let's divide them as shown.

$$4,5 = \frac{2,25}{0,25} \times \frac{x-48}{64}$$

That leaves us with

$$4,5 = 9 \times \frac{(x-48)}{64}$$

But if we're dividing a divisor, that second divisor can come up to the top row. Here's a simple example:

$$\begin{aligned} 1 \div (2 \div 3) &= \frac{1}{\frac{2}{3}} \\ &= \frac{1 \times 3}{2} \\ &= \frac{3}{2} = 1,5 \end{aligned}$$

If you doubt this, try it quickly on your calculator: $1 \div (2 \div 3)$... this means, one, divided by two-thirds. Well, two-thirds is 0,6667, which is almost one.

So how many "two-thirds" do you need to really make up one? The answer is one and a half "two-thirds"...

i.e. $0,6667 + (0,6667 \div 2) = 1$. Hence the answer is 1,5.

So, back to the original problem, we can bring the 64 up to the top line and multiply it by nine:

$$4,5 = 9 \times \left(\frac{x-48}{64} \right)$$

$$4,5 = \frac{9 \times 64}{x-48}$$

$$4,5 = \frac{576}{x-48}$$

Now we can inverse the entire equation to get the x onto the top:

$$\frac{1}{4,5} = \frac{x-48}{576}$$

Now we multiply both sides by 576 to remove the 576 from the bottom row

$$\frac{576}{4,5} = \frac{(x-48) 576}{576}$$

and we cancel the 576's on the right hand side as shown above.

$$\text{Now, if } 576 \div 4,5 = 128, \text{ then } 128 = x - 48$$

Now we add 48 to both sides to move the 48 across

$$128 + 48 = x - 48 + 48 \dots \text{ hence, } 128 + 48 = x = 176.$$

e.g. 4

A triangle has a base of 6 cm and a perpendicular height of 2 cm. Determine its area.

Step 1: Write down the value that you need to find.	Need to find: Area
Step 2: Write down the information that you have. Write down the numbers and the units.	base = 6 cm height = 2 cm
Step 3: Write down the formula that you are going to use.	Area = $\frac{1}{2}$ base \times height
Step 4: Write down the formula again, but write the numbers that you know instead of the words or letters.  We call this process substituting.	Area = $\frac{1}{2} \times 6 \text{ cm} \times 2 \text{ cm}$
Step 5: Now calculate.	= 3 cm \times 2 cm
Step 6: Write your answer with the correct units.	= 6 cm ²

e.g. 5

Calculate the area and the perimeter of the triangle alongside.

This looks like an easy problem, but you need to stay on your toes. As you follow the steps you will see why.

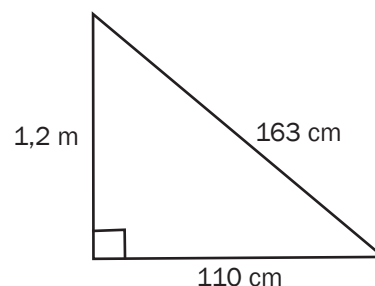

Step 1: Write down what you need to find.	Need to find: Area and Perimeter. Let's start with area.
Step 2: Write down the information that you have.	From the diagram: base = 110 cm height = 1,2 m The sides of the triangle are at right angles to each other, so one side is the perpendicular height.  The units of the two lengths are not the same. Always write the values with the same units. height = 1,2 m = 120 cm (because 100 cm = 1 m)
Step 3: Write down the formula.	Area = base \times height = $\frac{1}{2} \times$ height
Step 4: Write down the formula again, but write the numbers that you know instead of the words.	Area = $\frac{1}{2} \times 110 \text{ cm} \times 120 \text{ cm}$
Step 5: Now calculate.	= 55 cm \times 120 cm
Step 6: Write your answer with the correct units.	= 6 600 cm ²
Step 7: Calculate the perimeter.	Perimeter = 120 + 163 + 110 = 393 cm

e.g. 6

In the United States, people use degrees Fahrenheit to measure temperature. Convert 67 °F into degrees Celsius (°C). Round off your answer to two decimal places.

The formula to use is $^{\circ}\text{C} = (^{\circ}\text{F} - 32^{\circ}) \div 1,8$.

Need to find: Temperature in degree Celsius.	Notes
Information we have: Temperature in degrees Fahrenheit = 67 °F.	
$^{\circ}\text{C} = (67^{\circ} - 32^{\circ}) \div 1,8$	Replace °F with 67° in the formula: $^{\circ}\text{C} = (^{\circ}\text{F} - 32^{\circ}) \div 1,8$.
$^{\circ}\text{C} = 35^{\circ} \div 1,8$	Remember the order of operations: Calculate the brackets first and then do the division.
$^{\circ}\text{C} = 19,444 \dots^{\circ}$	Round off to two decimal places.
Temperature in degrees Celsius = 19,44 °C	Look at the number in the third decimal place. It is less than 5, so round the second decimal place down.

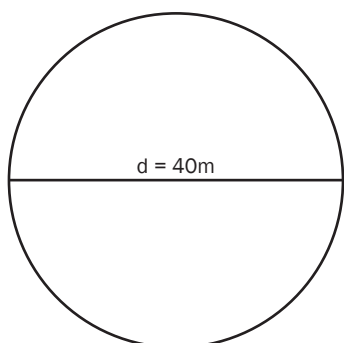

e.g. 7

A circular piece of land has a diameter of 40 m. What is the area of the land?

Use the formula: $A = \pi r^2$ for the area of a circle and use the value of 3,142 for π .

Need to find: Area	Notes
Information we have: diameter = 40 m; $\pi = 3,142$	 <p>Always make sure you use the quantity that is written in the formula – radius, not diameter.</p>
But we need the radius, which is half of the diameter, so $r = 20$ m.	
$A = \pi r^2$	
$A = 3,142 \times (20)^2$	$A = \pi r^2$ means Area = pi times the radius squared.
$A = 3,142 \times (20 \times 20)$ $A = 3,142 \times 400$	
$A = 1\,256,8 \text{ m}^2$	Are the units right? Yes, the diameter was given in metres, so the area will be in square metres (m^2).



When we work with a formula, we want the quantity that we are calculating on its own on one side of the formula, so that it is the subject of the formula.

We can work out area easily if the formula is $\text{Area} = \text{length} \times \text{breadth}$. Now let's use the same formula to find the length.

1.	Look at the formula. Which is the quantity that you want to calculate?	$\text{Area} = \text{length} \times \text{breadth}$
2.	What do you need to do to get length on its own? Length is multiplied by breadth. We need to divide by breadth to leave length on its own.  You can only do something to a formula if you do the same to both sides!	
3.	Divide both sides by breadth:	$\text{Area} \div \text{breadth} = \text{length} \times \text{breadth} \div \text{breadth}$
4.	Now simplify the formula: $\text{area} \div \text{breadth}$	$= \text{length}$ (because: $\text{breadth} \div \text{breadth} = 1$)
5.	Length =	$\text{area} \div \text{breadth}$
6.	Use the formula to solve the problem by substituting the values for area and breadth.	



To calculate the profit made from selling an item, we use the formula:

$\text{profit} = \text{selling price} - \text{cost price}$.

But what if we already know the profit and the cost price, but we need to calculate the selling price?

An example: It costs R121 to buy a necklace at cost price, and Thabo wants to make R65 profit. How much must he sell it for? (What is the selling price?)

		Selling price
1.	Look at the formula. Which is the quantity that you want to calculate?	$\text{profit} = \text{selling price} - \text{cost price}$ $P = SP - CP$
2.	Substitute the values that you have i.e. profit and cost price.	$R65 = SP - R121$
3.	Add cost price to both sides.	$R65 + R121 = SP - R121 + R121$
4.	Now simplify.	$R186 = SP$ (because $\text{cost price} - \text{cost price} = 0$)



This example has a fraction in it. See what you need to do in that case to make a quantity the subject of the formula.

5 miles is approximately the same as 8 kilometres. The formula to convert kilometres to miles is:

$$\text{number of miles} = \frac{5}{8} \times \text{number of kilometres.}$$

Gavin has cycled 30 miles and he wants to know what this is in kilometres. The formula must start with “number of kilometres = ...”

Rearrange the formula. Then work out how many kilometres he has cycled.

1.	Look at the formula. Which is the quantity that you want to calculate?	number of miles = $\frac{5}{8} \times$ number of kilometres
2.	Number of kilometres is multiplied by $\frac{5}{8}$. So we need to multiply by $\frac{8}{5}$ because $\frac{5}{8} \times \frac{8}{5} = 1$.	
3.	Multiply both sides by $\frac{8}{5}$.	number of miles $\times \frac{8}{5} = \frac{5}{8} \times$ number of kilometres $\times \frac{8}{5}$
4.	Now simplify the formula: Move the “ $\times \frac{8}{5}$ ”.	number of miles $\times \frac{8}{5} = \frac{5}{8} \times \frac{8}{5} \times$ number of kilometres
	Cancel out: $\frac{5}{8} \times \frac{8}{5} = 1$.	number of miles $\times \frac{8}{5} =$ number of kilometres
5.	Now we have number of kilometres = number of miles $\times \frac{8}{5}$	
6.	Use the formula to solve the problem. You can do this in your head: $30 \times 8 = 240$ $240 \div 5 = 48$ Or use a calculator: 30 [\times] 8 [\div] 5 [=]	number of kilometres = number of miles $\times \frac{8}{5}$ number of kilometres = $30 \times \frac{8}{5} = 48$ km Gavin cycled 48 km.



Thami needs to make a circle with an area of 40 cm^2 . What should the radius of the circle be? Round off your answer to two decimal places.

The formula for the area of a circle is $A = \pi r^2$. Use the value of 3,142 for π .

1.	Look at the formula. Which is the quantity that you want to calculate?	$A = \pi r^2$
2.	What do you need to do to get radius on its own on one side of the equation? There are two things: <ul style="list-style-type: none"> • radius is first squared • then it is multiplied by pi (π) 	
3.	Divide both sides by π	$Area \div \pi = \pi r^2 \div \pi$
4.	When then have Which we write as:	$Area \div \pi = r^2$ $\frac{area}{\pi} = r^2$
	Now take the square root of both sides.	$\sqrt{\frac{Area}{\pi}} = \sqrt{r^2}$
5.	Now we have $r = \sqrt{\frac{Area}{\pi}}$	
6.	Use the formula to solve the problem, by substituting the given values. To do this on your calculator: first enter $40 \div 3,142 =$ Then press $\sqrt{}$ Round off to two decimal places	$r = \sqrt{\frac{Area}{\pi}}$ $r = \sqrt{\frac{40}{3,142}} = 3,568 \dots$ $r = 3,57 \text{ cm}$ She needs to make the circle with a radius of 3,57 cm.

3. Statistics

You should at least know the following terminology:

Dependent variable: The thing that comes out of an experiment, the effect; the results.

Independent variable(s): The things that act as input to the experiment, the *potential* causes. Also called the *controlled* variable.

Control variable: A variable that is held constant in order to discover the relationship between two other variables. “Control variable” must not be confused with “controlled variable”.

Correlation does not mean causation. That is, if two variables seem to relate to each other (they seem to co-relate), it doesn’t mean that one causes the other. A variable only *causes* another variable if one of the variables is a function $f(x)$ of the other. We will see more about this when we look at graphs, below.

Mean: The average. In the series 1, 3, 5, 7, 9, the mean is $1 + 3 + 5 + 7 + 9$ divided by 5, since there are 5 bits of data. The mean in this case is 5.

Median: The datum (single bit of data) in the precise middle of a range of data. In the series 1, 3, 5, 7, 9, the median value is 5.

Mode: The most common piece of data. In the series 1, 1, 2, 2, 3, 3, 3, 4, 5, the mode is 3.

4. Triangles

The area of a triangle is half the base times the height: $A = \frac{b}{2}(h)$. A triangle with a base of 5 cm and a height of 3 cm will have an area of $2,5 \times 3 = 7,5 \text{ cm}^2$.

$$A = 7,5$$

b Base

5

h_b Height

3

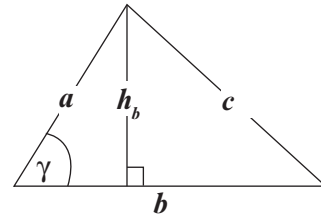

Lengths of Triangle Sides

You can calculate the lengths of sides of right-angled triangles using Pythagoras' Theorem. The square of the hypotenuse is equal to the sum of the squares of the other two sides: In this diagram, b = base, h_b = height, and c = the hypotenuse: $c^2 = h_b^2 + b^2$.

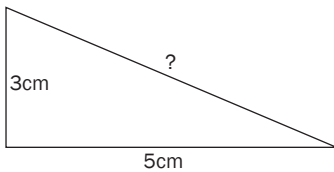

In the triangle shown, the hypotenuse, marked “?”, can be obtained by squaring both sides, adding them, and then square-rooting them for the length of the hypotenuse. That is: $3^2 + 5^2 = 9 + 25 = 34$. Since in this case $34 = \text{hyp}^2$ it follows that the square root of 34 gives the value of “?”, the hypotenuse. That is, 5,83cm.

5. Trigonometry

You can use trigonometry to calculate triangle sides' sizes if you do not have enough information, e.g. you do not have the sizes of at least two sides (but do have the angle).

\sin	=	opposite / hypotenuse	$\sin = O/H$
\cos	=	adjacent / hypotenuse	$\cos = A/H$
\tan	=	opposite / adjacent	$\tan = O/A$

It's probably easiest to remember this as SOHCAHTOA (soak a toe or soccer toe).

Hypotenuse is the longest side next to to the angle, usually represented with a theta (θ). “Opposite” means the side of the triangle directly opposite the angle. “Adjacent” means the side adjacent to (next to) the angle, that is not the hypotenuse.

e.g. 13

In this triangle, the side opposite the angle θ is 3cm long. The side adjacent to the angle θ , and the hypotenuse, are unknown. Theta, the angle, is 30 degrees.

How do we calculate the hypotenuse? Well,

$$\sin \theta = \frac{O}{H} = 3 \text{ cm} \div H.$$

$$\sin 30^\circ = 0,5 \text{ (you can get this from your calculator, or memorise it).}$$

thus

$$0,5 = \frac{3}{H}$$

solving for H, we multiply throughout by H to make H the subject of the formula:

$$H \times 0,5 = 3 \times H \div H$$

$$H \times 0,5 = 3$$

now divide throughout by 0,5 to isolate the H:

$$H \times 0,5 \div 0,5 = 3 \div 0,5$$

$$H = 3 \div 0,5 \therefore H = 6 \text{ cm}$$

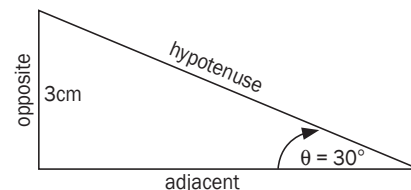

Let's try work out what the adjacent side is equal to, assuming we don't know the hypotenuse.

$$\tan \theta = \frac{O}{A}$$

$$\tan 30^\circ = 3 \text{ cm} \div A$$

$$0,57735 = 3 \div A$$

$$A \times 0,57735 = 3 \times A \div A$$

$$A \times 0,57735 = 3$$

$$A = 3 \div 0,57735$$

$$A = 5,196 \text{ cm} \approx 5,2 \text{ cm.}$$

Let's check this with Pythagoras. Suppose we want to prove that the opposite side is 3 cm. We have $H = 6$ and $A = 5,2$. So, Pythagoras tells us that $A^2 + O^2 = H^2$. So,

$$5,2^2 + O^2 = 6^2$$

$$O^2 = 6^2 - 5,2^2$$

$$O^2 = 36 - 27$$

$$O^2 = 9$$

So the square root of O^2 will give us O namely, $O = 3 \text{ cm}$. The trigonometric calculation is correct.

Lastly, there are three other operations you can do in trigonometry, but they're just inverses of the first three: cosecant, secant and cotangent. Cosec, sometimes abbreviated csc, is the reciprocal (inverse) of sine. Sec is the inverse of cosine. And cot is the inverse of tangent. So this means if $\sin = O/H$, then $\text{cosec} = H/O$, and so on.

e.g. 14

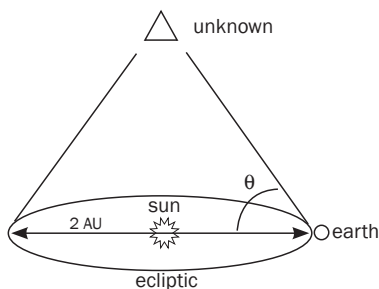

Earth orbits the sun at a distance of 149 597 870 700 metres or 149 597 870,7 km (one hundred and forty nine million km). This distance is called the AU, or astronomical unit. The flat disc that corresponds to earth’s orbit is called the ‘ecliptic’. Suppose that on 21 December, an unknown object is observed at an angle of 88° to the ecliptic, and that on June 21 the same object is observed at 92°. How far is the unknown object in AU?



Step by Step

Solution

Step 1. Ignore extra information. Since the earth orbits the sun, the angle to the unknown object relative to the earth is the same in both cases; it’s just that on one date, the earth is on one side of the unknown object, and on the other date, it is on the other side.

From the angles given, you can tell that the unknown object is at 90° to the sun relative to the earth.

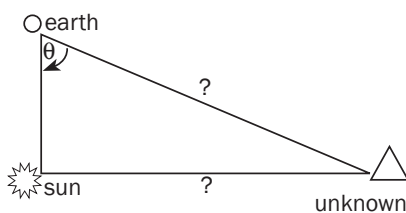

Step 2. We know the angle to the unknown object, and the distance to the sun. So, if we draw a triangle where the sun is the right-angle, the earth is at the tip of the hypotenuse, and the distant unknown object is opposite the sun, we get the following triangle.

So, we want the hypotenuse. We know that triangles add up to 180°, so the difference between θ and the given angle of 88° is 2°. That means that the angle the unknown object makes in reference to earth is 2°.

Thus:

$$\begin{aligned} \sin \theta &= \frac{O}{H} \\ \sin 2^\circ &= 1 \text{ AU} \div H = 149\,597\,870,7 \text{ km} \div H \\ 0,035 &= 149\,597\,870,7 \text{ km} \div H \\ H &= 149\,597\,870,7 \text{ km} \div 0,035 \\ H &= 4\,286\,533\,756,4964 \text{ km} = 28,6 \text{ AU} \end{aligned}$$

This means that the unknown object is 4,2 billion km away, or 28,6 AU away.

6. Graphs

It’s probably best to start from scratch with Cartesian Coordinates.

“Coordinates” are numbers that refer to the distance of a point along a line, or on a surface, or in space, from a central point called the “origin”. Graphs that you will use have only two dimensions (directions). The positions of points on these graphs are described using two coordinates: how far across (left-to-right) the point is, called the *x*-coordinate, and how far up-or-down on the page the point is, called the *y*-coordinate.

e.g. 15

Consider the following graph. It shows six points in a straight line.

The coordinates shown can be described using what are called “ordered pairs”. For example, the furthest point in this graph is 3 units across on the “ x -axis” or horizontal line. Likewise, it is also 3 units up on the y -axis, or vertical (up and down) line. So, its coordinates are (3;3). The point just below the midpoint or “origin”, is one unit down of the x -axis, and one unit left of the y -axis. So its coordinates are (-1;-1). Note that anything to the left or below of the origin (the circle in the middle), takes a minus sign.

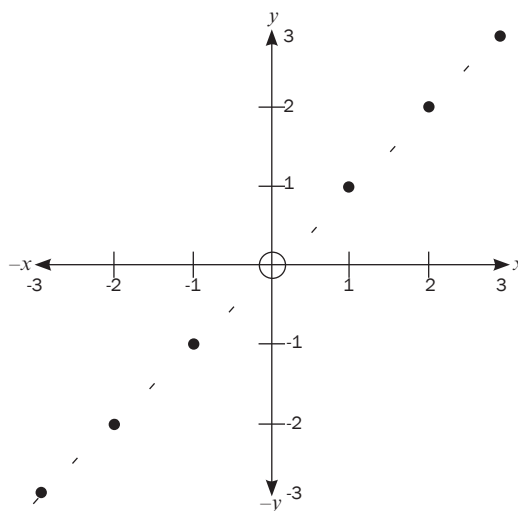

This series of dots look like they’re related to each other, because they’re falling on a straight line. If you see a result like this in an experimental situation, it usually means that you can predict what the next dot will be, namely, (4;4). This kind of prediction is called “extrapolation”. If you carry out the experiment, and find that the result is (4;4), and then (5;5), you’ve established that there is a strong relation or correlation.

Now, another way of saying that x relates to y , or x is proportional to y , is to say that y is a function of x . This is written $y = f(x)$. So, in the example given above, voltage is a function of resistance. But how is y related to x in this graph? Well, it seems to be in a 1 to 1 ratio: $y = x$. So the formula for this graph is $y = x$. In this case, we’re only dealing with two factors; $y = x$ and y .

e.g. 16

Now, let’s take a slightly more complex case, illustrated next to this paragraph.

In this next graph, we see that wherever x is equal to something, y is one more. So, trace your finger from the bottom left dot upwards. It meets the x -axis at the point -3. Do the same for the same point towards the y -axis. You’ll see it meets the y -axis at -2. You’ll see the next coordinates are (-2;-1), then (-1;0), then (0;1), (1;2), and finally (2;3). From this we can see that whatever x is, y is one more. So, $y = x + 1$ is the formula for this line.

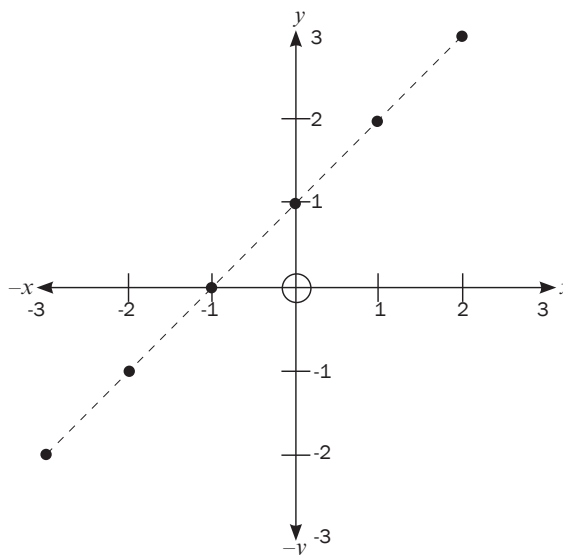

e.g. 17

Let’s take another case. In this next case, we see the following values: where x has a certain value, y has double that value. Let’s tabulate it. When x is 1, y is 2, when x is 2, y is 4. Thus, the formula for this line is: $y = 2x$. This value next to x is called the “gradient” or “slope” of the line. The larger the value next to x is, i.e. the larger the gradient, the steeper the slope. The gradient is usually abbreviated as “ m ” when it is unknown.

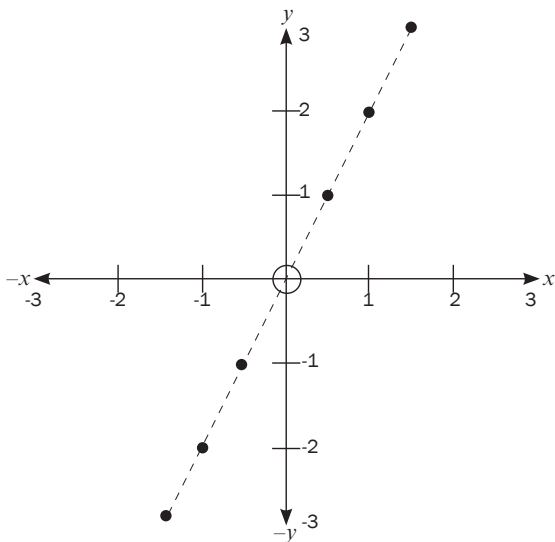

x	y
1,5	3
1	2
0,5	1
0	0
-0,5	-1
-1	-2
-1,5	-3

Let's do one more case. In this case, we can see that y is a function of x , since it's a straight line graph. However, it's not that easy to see the relationship between x and y . We can see that the slope is the same as the previous graph, so it must be something like $y = 2x$. However, it doesn't quite make sense, since $2(-1,5)$ is not -2 . We see that where x is zero (at the origin), y is at 1. But the slope is the same, so it must be $y = 2(0) + 1$. So the formula is: $y = 2x + 1$.

As you can see, this is where mathematicians get the general equation for a straight line of $y = mx + c$. ("c" stands for "constant").

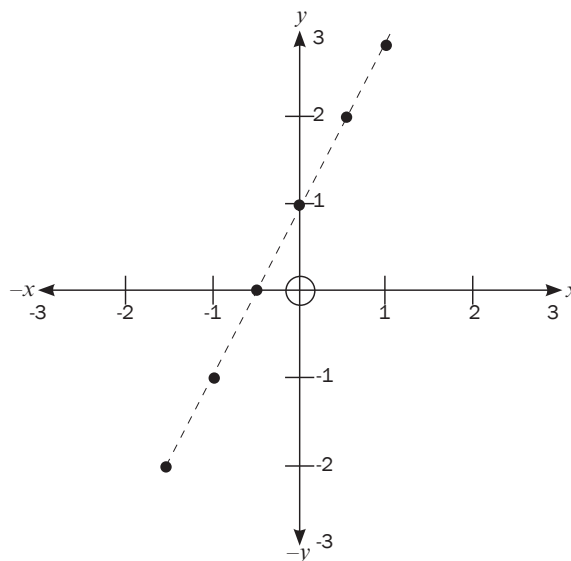

x	y	$2x + 1$
-1,5	-2	$2(-1,5)+1 = -3+1 = -2$
-1	-1	$2(-1)+1 = -2+1 = -1$
-0,5	0	$2(-0,5)+1 = -1+1 = 0$
0	1	$2(0)+1 = 0+1 = 1$
0,5	2	$2(0,5)+1 = 1+1 = 2$
1	3	$2(1)+1 = 2+1 = 3$

7. Circles

- Diameter is the width of a circle ($2r$); radius is half the diameter ($d/2$). The edge of a circle is called the “circumference”. “Diameter” means to “measure across”. Compare “diagonal” which means an *angle across* a square or rectangle, so “dia-” means “across” (Greek). “Circumference” means to “carry in a circle” (Latin); think of how the earth carries us in a circle or orbit around the sun. To remember the difference between these things, just remember that the sun’s rays radiate out from the sun in every direction, so the radius is the distance from the centre of a circle, e.g. the sun, to the outer edge of a circle surrounding it, e.g. earth’s orbit (the circumference).
- Area of a circle = πr^2
- Circumference = $2 \pi r$
- You can use the above to solve for radius or diameter.

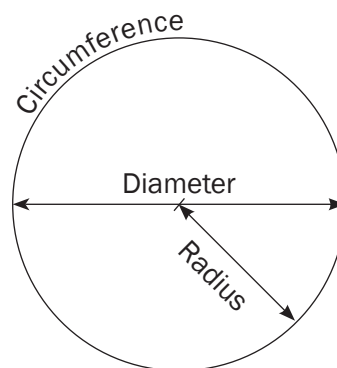

8. Reading Tables

8.1 Reading Tables

A table is a way of showing information in rows and columns.

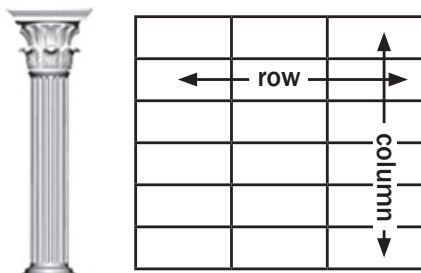

A row goes right across.
A column in a building is upright.

Getting information from tables

Reading a table means finding information in the cells. Each block in a table is called a cell. Reading a table is like reading a grid.

Look at the table on the right.

A and B are the column headings.

1, 2, 3, 4, and 5 are the row headings.

- What is in A2? Go across to column A and read down to row 2. A bell.
- What is in B3? A hand.
- Give the row and column for the star. Row 4 and column A. You can also write A4.
- Give the row and column for the clock. Row 5 and column B. You can also write B5.

	A	B
1.		
2.		
3.		
4.		
5.		



Look at the table below. In a question, you might have to find information in the table and write it down, or you might have to use the information in the table to do a calculation.

The table below shows the average maximum and minimum temperatures (highs and lows) in Mauritius (measured in degrees Celsius) each month.



This shows that in April the average maximum temperature was 29 °C. This shows that in November the average minimum temperature was 22 °C.



The table doesn't have units in the cells, but we know the units because they are in the headings for each column. Always give the units in your answer.



Be careful! Here we are still working with the **average maximum temperature** column.



The difference between the lowest and highest numbers is called the **range**.

Average monthly maximum and minimum temperatures in Mauritius

Month of the year	Average maximum temperature °C	Average minimum temperature °C
January	35	24
February	30	22
March	30	21
April	29	21
May	25	19
June	24	17
July	26	18
August	27	19
September	29	20
October	32	22
November	32	22
December	34	24

Look at the table above to answer these questions.

1. Which month of the year had the highest average maximum temperature in Mauritius?
2. Which month had the lowest average maximum temperature?
3. What is the difference between the average maximum temperature in December and the average minimum temperature in December?

Solution

1. Reading down the **average maximum temperature** column, you can see that January has a temperature of 35 °C, and none of the other temperatures are higher.
2. The lowest maximum temperature is 24 °C in June.
3. Here you will need to find the row for December and look across to get the lowest and highest temperatures for that month, then subtract the lowest temperature from the highest temperature to find the difference: $34 - 24 = 10^{\circ}\text{C}$.



The average monthly increases in the cost of electricity (excluding VAT) between 2011 and 2012

	Electricity consumption in kWh			
	50	150	600	1 000
Amount payable in 2011	R27,35	R85,83	R393,67	R728,63
Amount payable in 2012	R28,83	R94,99	R467,43	R888,83
Increase between 2011 and 2012	R1,48	R9,16	R73,67	R160,20
Percentage increase between 2011 and 2012	5,39%	10,67%	18,74%	21,99%

Read from the table to answer the questions.

1. If a household used 600 kWh of electricity in 2011, what would they have paid?
2. How much more would you pay for 1 000 kWh of electricity in 2012 compared to 2011?
3. What was the percentage increase for 150 kWh of electricity between 2011 and 2012?
4. Was the percentage increase higher for lower electricity consumption, or for higher electricity consumption?

Solution

When you answer a question like this, take a few minutes to look at the table and write down some notes about what it shows. Don't get too detailed, just to understand what the table is showing.

↓ The columns show 4 different amounts of electricity consumption. The unit is kWh.

	Electricity consumption in kWh			
	50	150	600	1 000
Amount payable in 2011	R27,35	R85,85	R393,67	R728,63
Amount payable in 2012	R28,83	R94,99	R467,43	R8883,83
Increase between 2011 and 2012	R1,48	R9,16	R73,67	R160,20
Percentage increase between 2011 and 2012	5,39%	10,67%	18,74%	21,99%

→ Notice that there is an increase in costs this way.

First row shows the cost for 2011 and 2nd row shows 2012. This is what the table is comparing.

These amounts are calculated for us! These are differences between 2011 and 2012: Amount and Percentage.

1. Read off the 2011 row showing the amount, and the 600 kWh column: R393,67.
2. You don't have to calculate; this difference is given in the third row.
3. The percentage increase is given in the last row. So look at the last row and second column (for 150 kWh): 10,67%.
4. In the fourth row, there is a steady increase in the percentages from lower to higher electricity consumption. So the percentage increase is bigger for higher consumption.



The question is asking for the increase in the amount of money. So we are interested in the third row. The consumption is 1 000 kWh, so look at the 4th column and third row: R160,20.

8.2 Reading Two-Way Tables

Two-way tables are a useful way to display information, and they help you to work out missing information.

These tables show the numbers of two categories for the same sample. One category is shown in rows, and the other category is shown in columns.

For example, the table below shows how many Grade 12 learners in a school own a cell phone or not and how many of the same learners own a music player or not.



These numbers are for the same group of learners.

	Own an MP3 player	Do not own an MP3 player
Own a cell phone	57	21
Do not own a cell phone	13	9

What's interesting about this table is that the totals of both columns and the totals of both rows are the same. We can see that the sample was of 100 learners.

	Own an MP3 player	Do not own an MP3 player	Total
Own a cell phone	57	21	78
Do not own a cell phone	13	9	22
Total	70	30	100



During one month, 75 of the 180 babies born in a hospital were boys, and 40 of the babies weighed 4 kg or more. There were 26 baby boys who weighed 4 kg or more.

- Put this information in a two-way table and fill in the missing numbers.
- What percentage of girl babies weighed 4 kg or more?

Solution

- First draw up the grid and fill in the information given. (It doesn't matter whether you put the weights or the gender in the columns or rows.)

	Boys	Girls	Total
Weighed less than 4 kg			
Weighed 4 kg or more	26	0	40
Total	75		180

When you've got the table in this form, you can find the missing information. Work back from the totals. For example, if 26 of the baby boys weighed 4 kg or more, then $75 - 26 = 49$ of them weighed less than 4 kg.

	Boys	Girls	Total
Weighed less than 4 kg	49	91	140
Weighed 4 kg or more	26	14	40
Total	75	105	180

- There were 14 girl babies who weighed 4 kg or more, out of a total of 105 girl babies.

$$\frac{14}{105} \times 100\% = 13,33\%$$



One hundred passengers on a bus trip were asked whether they wanted chicken or beef and whether they preferred rice or potato for their meals. Out of 30 passengers who liked rice, 20 liked chicken. There were 60 passengers who chose chicken.

1. Put this information in a two-way table and fill in the missing numbers.
2. How many meals with beef and potato should the bus company produce?

Solution

1. Here is the information we are given:

	Chicken	Beef	Total
Rice	20		
Potato			
Total	60		

Here are the rest of the information:

	Chicken	Beef	Total
Rice	20	10	30
Potato	40	30	70
Total	60	40	100

Exponents and surds

To understand exponents and surds, you need to revise the number system thoroughly.

1.1 The number system

1.1.1 Real numbers

The numbers that we work with every day are called real numbers.

The set of real numbers has subsets shown in the Venn diagram:

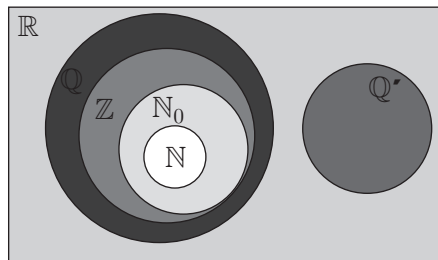

All terminating, recurring decimals are rational numbers examples:
 $0.\dot{3}$; $2,7\dot{1}$; $5,321784571$



1. Natural Numbers

$\mathbb{N} = \{1; 2; 3; \dots\}$ (positive whole numbers)

2. Whole Numbers

$\mathbb{N}_0 = \{0; 1; 2; \dots\}$ (Natural numbers and 0)

3. Integers

$\mathbb{Z} = \{\dots; -3; -2; -1; 0; 1; 2; 3; \dots\}$

4. Rational Numbers

- A rational number is a Real number which can be written in the form $\frac{a}{b}$, where $a, b \in \mathbb{Z}$ and $b \neq 0$. The rational numbers **include** all the integers.

e.g. 1 $5; \sqrt{16}; \sqrt[3]{8}; \frac{3}{7}; \frac{-13}{9}; \frac{132}{1}; \frac{22}{7}; \frac{-16}{4}; 3,14; 0,\dot{3} = \frac{3}{10}; 2,7\dot{1} = \frac{269}{99}$

5. Irrational Numbers

- Irrational numbers are numbers that cannot be written as fractions.
- All decimals that do not terminate or recur are irrational.



Pi (π) is an interesting irrational number. It is the ratio of the circumference to the diameter of any circle:

$$\pi = \frac{\text{circumference of circle}}{\text{diameter of circle}} = 3,141592653 \dots$$

NOTE:

$\frac{22}{7}$ and 3,14 are approximate

rational numbers that have a value close to π .

So $\frac{22}{7} \neq \pi$ and $3,14 \neq \pi$

e.g. 2 $\sqrt{5} = 2,23606\dots$ $\pi (\pi) = 3,141592\dots$

- They have decimals that continue indefinitely with no pattern.
- Look at these numbers on a calculator.
- The calculator will round them off. However, they continue indefinitely without a pattern.
- The symbol for the irrational numbers is \mathbb{Q}' , which means the complement of \mathbb{Q} or **not** \mathbb{Q} .

Some quadratic equations do not have real roots, but some do



6. Real Numbers

The set of real numbers, \mathbb{R} , is the set of all rational and irrational numbers together.

We can also write $\mathbb{R} = \mathbb{Q} \cup \mathbb{Q}'$

e.g. 3 $-3; -\sqrt{7}; -1\frac{1}{4}; -1; 0; \frac{1}{2}; 1; \sqrt{2}; 2; 3; \pi$

1.1.2 Non-real Numbers

The square root (or any even root) of a negative number, is a non-real number.

e.g. 4 $\sqrt{-25}$ is a non-real number.
 $\sqrt[4]{-100}$ is a non-real number
 $\sqrt[6]{-120}$ is a non-real number

- The calculator will show an error.

e.g. 5 $x^2 + 5x + 9 = 0$

Use the quadratic formula to find the values of x :

$$\begin{aligned} x &= \frac{-b \pm \sqrt{b^2 - 4ac}}{2a} \\ &= \frac{-5 \pm \sqrt{5^2 - 4(1)(9)}}{2(1)} \\ &= \frac{-5 \pm \sqrt{25 - 36}}{2} \\ &= \frac{-5 \pm \sqrt{-11}}{2} \end{aligned}$$

$\sqrt{-11}$ is a non-real number so the value of x is non-real. There are no real roots for the equation, so the graph of the function $y = x^2 + 5x + 9$ has no intercepts with the x -axis.

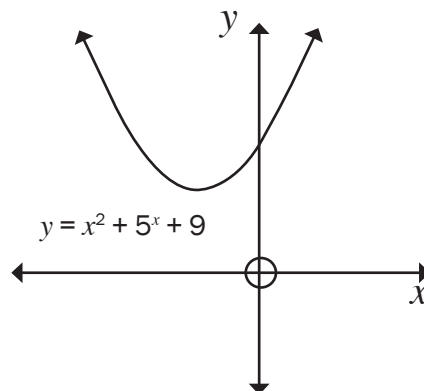

You will learn more about the nature of roots in Unit 2.



Any $\frac{\text{number}}{0} = \text{undefined}$
 The calculator will also show an error.

1.2 Working with irrational numbers

1.2.1 Surds

All square roots; cube roots, etc. that they are not rational are called **surds**.

$\sqrt{2}$; $\sqrt{3}$; $\sqrt{5}$; $\sqrt{6}$; $\sqrt{7}$; $\sqrt{8}$; are all surds.

Surds are real numbers which when expressed as decimals are non-recurring and non-terminating.

We can work out where a surd lies between two integers on a number line.

e.g. 6 $\sqrt{1} = 1$ and $\sqrt{4} = 2$, so $\sqrt{2}$ lies somewhere between 1 and 2.
 $\sqrt[3]{64} = 4$ and $\sqrt[3]{125} = 5$, so $\sqrt[3]{102}$ lies between 4 and 5.

We can show their approximate positions on the number line:



Some roots or radical numbers are rational and are not surds:

e.g. 7 Examples of roots that are not surds include:
 $\sqrt{1} = 1$; $\sqrt{4} = 2$; $\sqrt{9} = 3$; $\sqrt[3]{8} = 2$; $\sqrt[4]{81} = 3$

1.2.2 Simplifying surds

e.g. 8

1. $\sqrt{5} \times \sqrt{3} = \sqrt{15}$ ✓ (1)
2. $(\sqrt{5})^2 = \sqrt{5} \times \sqrt{5} = 5$ ✓ (1)
3. $\sqrt[3]{\frac{8}{27}} = \frac{\sqrt[3]{8}}{\sqrt[3]{27}} = \frac{2}{3}$ ✓✓ (2)
4. $\sqrt{a^2 - b^2}$ cannot be simplified
5. $\sqrt[3]{27^4} = \sqrt[3]{(3^3)^4} = \sqrt[3]{3^{12}} = 3^{\frac{12}{3}} = 3^4 = 81$ ✓ (2)
6. $\sqrt{9 + 16} = \sqrt{25} = 5$ ✓ (1)
7. $\sqrt{9} + \sqrt{16} = 3 + 4 = 7$ ✓ (1)



$$\sqrt{9 + 16} \neq 3 + 4$$



Activity 1

Write in simplest form without using a calculator (show all working).

- $\sqrt{8} \times \sqrt{2}$
- $\sqrt[3]{4} \times \sqrt[3]{2}$
- $\frac{9 + \sqrt{45}}{3}$
- $(2 + \sqrt{5})(2 - \sqrt{5})$

[10]

Solutions

$$1. \sqrt{8} \times \sqrt{8} = \sqrt{8 \times 8} = \sqrt{64} = 8 \checkmark \quad (1)$$

$$2. \sqrt[3]{4} \times \sqrt[3]{2} = \sqrt[3]{4 \times 2} \checkmark = \sqrt[3]{8} = 2 \checkmark \quad (2)$$

$$3. \frac{9 + \sqrt{45}}{3} = \frac{9 + 3\sqrt{5}}{3} \checkmark = \frac{3(3 + \sqrt{5})}{3} \checkmark = 3 + \sqrt{5} \checkmark \quad (3)$$

$$4. (2 + \sqrt{5})(2 - \sqrt{5}) \\ = 2 \times 2 - \sqrt{5} \times \sqrt{5} \checkmark = 4 - 5 = -1 \checkmark \quad (2)$$

Or multiply out the brackets:

$$(2 + \sqrt{5})(2 - \sqrt{5}) = 4 + 2\sqrt{5} - 2\sqrt{5} - \sqrt{5} \cdot \sqrt{5} \checkmark = 4 - 5 = -1 \checkmark \quad (2)$$

[10]

1.2.3 Rationalising a denominator

When a fraction contains a surd in the denominator, you can change the denominator to a rational number. This is called 'rationalising the denominator'.

If you multiply the numerator and the denominator by the same surd, you are not changing the value of the number. You are multiplying by 1

(i.e. $\frac{\sqrt{2}}{\sqrt{2}} = 1$) to change what the number looks like, not its value. Doing this can give you a rational denominator.

e.g. 9

Rationalise the denominator of $\frac{\sqrt{3}}{\sqrt{2}}$.

$$\frac{\sqrt{3}}{\sqrt{2}} = \frac{\sqrt{3}}{\sqrt{2}} \times \frac{\sqrt{2}}{\sqrt{2}} = \frac{\sqrt{3} \times \sqrt{2}}{2} = \frac{\sqrt{6}}{2} \checkmark \quad (1)$$

Now the denominator is a rational value.

Check on a calculator: $\frac{\sqrt{3}}{\sqrt{2}} = \frac{\sqrt{6}}{2} = 1,2247\dots$

e.g. 10

$$\frac{3}{\sqrt{3} - 1}$$

$$= \frac{3}{\sqrt{3} - 1} \times \frac{\sqrt{3} + 1}{\sqrt{3} + 1} \checkmark$$

$$= \frac{3(\sqrt{3} + 1)}{(\sqrt{3} - 1)(\sqrt{3} + 1)} = \frac{3\sqrt{3} + 3}{3 + \sqrt{3} - \sqrt{3} - 1}$$

$$= \frac{3\sqrt{3} + 3}{2} \checkmark \quad (2)$$

(has an irrational number in denominator)

(multiply by $\frac{\sqrt{3} + 1}{\sqrt{3} + 1}$, since $1 = \frac{\sqrt{3} + 1}{\sqrt{3} + 1}$)

(notice how the surd terms cancel)

(now the denominator is rational)

hint

If the denominator is $\sqrt{3} - 1$, multiply by $\frac{\sqrt{3} + 1}{\sqrt{3} + 1}$. This will give us the difference of two squares.



Activity 2 Interpret a graph

1. Complete the table for each number by marking the correct columns.

	Non-real number	Real number \mathbb{R}	Rational number \mathbb{Q}	Irrational number \mathbb{Q}'	Integer \mathbb{Z}	Whole number \mathbb{N}_0	Natural number \mathbb{N}
a) 13							
b) 5,121212...							
c) $\sqrt{-6}$							
d) 3π							
e) $\frac{0}{9} = 0$							
f) $\sqrt{17}$							
g) $\sqrt[3]{64} = 4$							
h) $\frac{22}{7}$							

(23)

2. Which of the following numbers are rational and which are irrational?

- a) $\sqrt{16}$ b) $\sqrt{8}$ c) $\sqrt{\frac{9}{4}}$ d) $\sqrt{6\frac{1}{4}}$
 e) $\sqrt{47}$ f) $\frac{22}{7}$ g) 0,347347... h) $\pi - (-2)$
 i) $2 + \sqrt{2}$ j) 1,121221222...

(10)

[33]

Solutions

1.	Non-real number	Real number \mathbb{R}	Rational number \mathbb{Q}	Irrational number \mathbb{Q}'	Integer \mathbb{Z}	Whole number \mathbb{N}_0	Natural number \mathbb{N}
a) 13		✓	✓		✓	✓	✓
b) 5,121212...		✓	✓				
c) $\sqrt{-6}$	✓						
d) 3π		✓		✓			
e) $\frac{0}{9} = 0$		✓	✓		✓	✓	
f) $\sqrt{17}$		✓		✓			
g) $\sqrt[3]{64} = 4$		✓	✓		✓	✓	✓
h) $\frac{22}{7}$		✓	✓				

(5)

(2)

(1)

(2)

(4)

(2)

(5)

(2)

2. a) $\sqrt{16} = 4$ (rational) ✓ (1) b) $\sqrt{8}$ (irrational) ✓ (1)
 c) $\sqrt{\frac{9}{4}} = \frac{3}{2}$ (rational) ✓ (1) d) $\sqrt{6\frac{1}{4}} = \sqrt{\frac{25}{4}} = \frac{5}{2}$ (rational) ✓ (1)
 e) $\sqrt{47}$ (irrational) ✓ (1) f) $\frac{22}{7}$ (rational) ✓ (1)
 g) 0,347347... (rational, because it is a recurring decimal) ✓ (1)
 h) $\pi - (-2)$ (irrational, because π is irrational) ✓ (1)
 i) $2 + \sqrt{2}$ (irrational, because $\sqrt{2}$ is irrational) ✓ (1)
 j) 1,121221222... (irrational, because it is a non-recurring and non-terminating decimal) ✓ (1)

[33]

1.3 Exponents

The **exponent** of a number tells us how many times to multiply the number (the **base**) by itself.

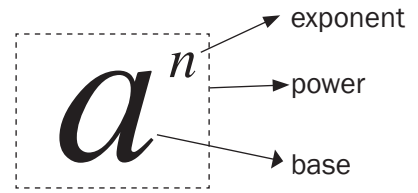

So $a^2 = a \times a$ $a^3 = a \times a \times a$

$a^n = a \times a \times a \times \dots$ n times

e.g. 11

3^4 read as: three to the power of 4, or 3 exponent 4 which is equal to $3 \times 3 \times 3 \times 3 = 81$

1.3.1 Rules of exponents

These rules work for exponents that are integers, rational numbers or irrational numbers.

<p>1. $a^m \times a^n = a^{m+n}$ To multiply two powers with same bases, add their exponents.</p>	<p>$a^5 \times a^3 = a^{5+3} = a^8$ $3^5 \times 3^3 = 3^{5+3} = 3^8$</p>
<p>2. $a^m \div a^n = a^{m-n}$ To divide two powers with same bases, subtract their exponents.</p>	<p>$a^8 \div a^2 = a^{8-2} = a^6$</p>
<p>3. $(a^m)^n = a^{mn}$ To raise a power to an exponent, multiply the exponents. $(ab)^m = (a^m b^m)$ $\left(\frac{a}{b}\right)^m = \frac{a^m}{b^m}$</p>	<p>$(a^4)^3 = a^{4 \times 3} = a^{12}$ $(a^2 \times b^3)^5 = a^{2 \times 5} \cdot b^{3 \times 5} = a^{10} \cdot b^{15}$ $(a^5/b^2)^3 = \frac{a^{5 \times 3}}{b^{2 \times 3}} = \frac{a^{15}}{b^6}$</p>
<p>4. $a^0 = 1$, Any base raised to 0 is 1</p>	<p>$(b)^0 = 1$; $(3)^0 = 1$; $(5a^2b^3)^0 = 1$</p>
<p>5. $\frac{1}{a^n} = a^{-n}$ A positive exponent in the denominator is the same as a negative exponent in the numerator. $\left(\frac{a}{b}\right)^{-m} = \left(\frac{b}{a}\right)^m$</p>	<p>$b^{-3} = \frac{1}{b^3}$ $b^3 = \frac{1}{b^{-3}}$ $\left(\frac{a}{b}\right)^{-3} = \left(\frac{b}{a}\right)^3$ $\left(\frac{2}{5}\right)^{-3} = \left(\frac{5}{2}\right)^3 = \frac{125}{8}$</p>
<p>6. $\sqrt[n]{a^m} = (a^m)^{\frac{1}{n}} = a^{\frac{m}{n}}$ ($n \geq 2$). To find the root of a power, divide the exponents.</p>	<p>$\sqrt{2} = \sqrt[2]{2^1} = (2^1)^{\frac{1}{2}} = 2^{\frac{1}{2}}$ $\sqrt{a} = \sqrt[2]{a^1} = (a^1)^{\frac{1}{2}} = a^{\frac{1}{2}}$ $\sqrt[3]{a^2} = (a^2)^{\frac{1}{3}} = a^{\frac{2}{3}}$</p>

1.3.2 Algebraic expressions with exponents

Remember to work in this order:

signs → values → variables

	Values	Variables	Answer
a) $-3a^3b^2 \times -4a^4b^4$	$-3 \times -4 = 12$	$a^3b^2 \times a^4b^4 = a^7b^6$	$= +12a^7b^6$
b) $12x^5y^8 \div -4x^2y^4$	$12 \div -4 = -3$	$x^5y^8 \div x^2y^4 = x^3 \cdot y^4$	$= -3x^3y^4$
c) $(-3a^3b^2)^3$	$(-3)^3 = -27$	$(a^3b^2)^3 = a^9b^6$	$= -27a^9b^6$
d) $\sqrt[4]{16a^{16}}$	$\sqrt[4]{16} = 2$ $(2^4 = 16)$	$\sqrt[4]{a^{16}} = a^4$	$= 2a^4$

Where necessary, we work out the inside set of brackets first and follow the order of operations:

BODMAS Brackets/Of, Division/Multiplication/Addition/Subtraction



Activity 3

Calculate

a) $-3((-2a^3)^2 + \sqrt{9a^{12}})$

$$\sqrt{9a^{12}} = (3^2a^{12})^{\frac{1}{2}}$$

b) $\frac{5(2a^4)^3}{(-5a^3)^2 - 5a^6}$

[5]

Solutions

$$\begin{aligned} \text{a) } & -3((-2a^3)^2 + \sqrt{9a^{12}}) \\ & = -3(4a^6 + 3a^6) \\ & = -3(7a^6) = -21a^6 \checkmark \end{aligned}$$

simplify exponents inside the brackets and the square root
add like terms inside the bracket
simplify (3)

$$\text{b) } \frac{5(2a^4)^3}{(-5a^3)^2 - 5a^6}$$

$$= \frac{5(8a^{12})}{+25a^6 - 5a^6} \checkmark = \frac{40a^{12}}{20a^6} = 2a^6 \checkmark$$

✓

(2)

[5]

1.3.3 Prime factors

When the bases are different, we can write each base as a product of its prime factors.

Remember: A prime number has only two different factors.

A composite number has more than two factors.

The number 1 is neither a prime number nor a composite number.

Prime numbers: 2; 3; 5; 7; 11; 13 ...

Every **composite number** can be written as **the product of prime numbers**.

This helps us to factorise and to simplify.



2^2	2	2 700
	2	1 350
3^3	3	675
	3	225
	3	75
5^2	5	25
	5	5

e.g. 12

$$4 = 2^2; \quad 6 = 2 \times 3; \quad 8 = 2^3; \quad 9 = 3^2; \quad 10 = 2 \times 5; \quad 12 = 2^2 \times 3$$

$$24 = 8 \times 3 = 2^3 \times 3$$

NOTE:

To find the factors of 2 700, divide by the lowest prime that is a factor eg 2; then move onto 3; then 5 etc.

$$2\,700 = 2^2 \times 3^3 \times 5^2 \quad \checkmark$$

Find out how your scientific calculator can calculate the prime factors of a number for you.



2^3	2	72
	2	36
	2	18
3^2	3	9
	3	3
		1

e.g. 13

Express 72^{x-2} in prime factors

$$\begin{aligned} 72^{x-2} &= (2^3 \cdot 3^2 \checkmark)^{x-2} \\ &= 2^{3(x-2)} \cdot 3^{2(x-2)} \\ &= 2^{3x-6} \cdot 3^{2x-4} \quad \checkmark \end{aligned}$$

1.3.4 Working with negative exponents

It is easier to write answers with positive exponents, so we use the exponent rule:

$$\frac{1}{a^n} = a^{-n} \quad \text{and} \quad \frac{1}{a^{-n}} = a^n$$

This also means that $\left(\frac{a}{b}\right)^{-2} = \left(\frac{b}{a}\right)^2$



Activity 4

Simplify the following. Write answers with positive exponents where necessary.

1. $\frac{a^{-3}}{b^{-2}}$ 2. $\frac{4a^7b^{-4}c^{-1}}{d^2e^5}$ 3. $x^{-1} + y^{-1}$

[5]

Solutions

1. $\frac{a^{-3}}{b^{-2}} = \frac{b^2}{a^3} \checkmark$ 2. $\frac{4a^7b^{-4}c^{-1}}{d^2e^5} = \frac{4a^7d^2}{b^4c^1e^5} \checkmark \checkmark$
 3. $x^{-1} + y^{-1} = \frac{1}{x} + \frac{1}{y} \checkmark = \frac{y+x}{xy} \checkmark$

[5]

NOTE: A surd is also called a radical.

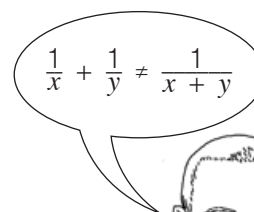

1.3.5 Working with surd (root) signs

The exponential rule $\sqrt[n]{a^m} = a^{\frac{m}{n}}$ ($a > 0; n \geq 2$), can be used to simplify certain expressions.



Activity 5

1. Rewrite these expressions without surd signs and simplify if possible.

a) $\sqrt[3]{5}$ b) $\sqrt[4]{16}$ c) $\sqrt[3]{-32}$

[3]

Solution

a) $\sqrt[3]{5} = 5^{\frac{1}{3}} \checkmark$ b) $\sqrt[4]{16} = 16^{\frac{1}{4}} = (2^4)^{\frac{1}{4}} = 2 \checkmark$
 c) $\sqrt[3]{-32} = (-32)^{\frac{1}{3}} = [(2)^5]^{\frac{1}{3}} = -2 \checkmark$

[3]

We can find a root of a negative number if the root is odd, but not the root of a negative number if the root is even.



e.g. 14

$\sqrt[3]{-27} = -3$ because $(-3)^3 = -27 \therefore \sqrt[3]{-27}$ is real

$\sqrt[4]{-16}$ is non-real

1.3.6 Watch out for these common mistakes!

Correct	Warning
1. $2^n \cdot 3^n = 6^n$	$2 \cdot 3^n \neq 6^n$
2. $3^4 \times 3^5 = 3^9$	$3^4 \times 3^5 \neq 9^9$
3. $4^{10} \div 4^5 = 4^5$	$4^{10} \div 4^5 \neq 4^2$ $4^{10} \div 4^5 \neq 1^5$ $4^{10} \div 4^5 \neq 1^2$
4. $(3b)^{n-1} = 3^{n-1}b^{n-1}$	$(3b)^{n-1} \neq 3 \cdot b^{n-1}$

5. $(a + b)^2 = a^2 + 2ab + b^2$	$(a + b)^2 \neq a^2 + b^2$
6. $\sqrt{16 \times 16} = 4x^8$	$[\sqrt{16 \times 16} \neq 4x^4]$
7. $\sqrt{a^2 + b^2} = (a^2 + b^2)^{\frac{1}{2}} \neq a + b$	$\sqrt{a^2 + b^2} \neq a + b$ e.g. $\sqrt{5^2 - 3^2} \neq 5 - 3 = 2$ because $\sqrt{5^2 - 3^2} = \sqrt{25 - 9} = \sqrt{16} = 4$
8. $3 \times^{-3} = \frac{3}{x^3}$	$3x^{-3} \neq \frac{1}{3x^3}$
9. $(x + y)^{-2} = \frac{1}{(x + y)^2}$	$(x + y)^{-2} \neq x^{-2} + y^{-2}$

1.3.7 Simplification of exponential expressions



Activity 6

Simplify the following and leave answers with positive exponents where necessary:

$$\frac{(a^4)^{n-1} \cdot (a^2b)^{-3n}}{(ab)^{-2n} \cdot b^{-n}}$$

[4]

Solution

$$\begin{aligned} \frac{(a^4)^{n-1} \cdot (a^2b)^{-3n}}{(ab)^{-2n} \cdot b^{-n}} &= \frac{a^{4n-4} \cdot a^{-6n} \cdot b^{-3n}}{a^{-2n} \cdot b^{-2n} \cdot b^{-n}} \checkmark \\ &= a^{4n-4-6n+2n} \cdot b^{-3n+2n+n} \checkmark \\ &= a^{-4} \cdot b^0 \checkmark \\ &= \frac{1}{a^4} \cdot 1 = \frac{1}{a^4} \checkmark \end{aligned}$$

[4]

1.3.8 Algebraic fractions with exponents

1. Expressions with only products of terms

- Factorise the terms using prime factors.
- Use laws of exponents.



$$\begin{aligned} \frac{5^{2n} \cdot 9^{2n-3}}{15^{2n} \cdot 3^{4n-1}} &= \frac{5^{2n} \cdot (3^2)^{2n-3}}{(5 \cdot 3)^{2n} \cdot 3^{2n-1}} \checkmark && \text{(use prime number bases)} \\ &= \frac{5^{2n} \cdot 3^{4n-6}}{5^{2n} \cdot 3^{2n} \cdot 3^{2n-1}} \checkmark \checkmark && \text{(to remove brackets, } \times \text{ exponents)} \\ &= 5^{2n-2n} \cdot 3^{4n-6-2n-(2n-1)} \checkmark && \text{(same bases } \times / \div \text{,} \\ &&& \text{add/subtract exponents)} \\ &= 5^0 \cdot 3^{4n-6-2n-2n+1} \\ &= 1 \cdot 3^{-5} = 1 \times \frac{1}{3^5} && \text{(write negative exponent as positive} \\ &&& \text{exponent)} \\ &= \frac{1}{243} \checkmark \end{aligned}$$

2. Expressions with terms added or subtracted

- First try to factorise both the numerator and denominator.
- Use laws of exponents.
- Cancel any common factors.

 **16**

$$\begin{aligned} \frac{(3^n)^2 + 3^{2n-1}}{9^n} &= 3^{2n} + \frac{3^{2n} \cdot 3^{-1}}{3^{2n}} \\ &= \frac{3^{2n}(1 + 3^{-1})}{3^{2n}} \quad \checkmark\checkmark \quad \text{(factorise: take out HCF)} \\ &= 1 \frac{1}{3} = \frac{4}{3} \quad \checkmark \end{aligned}$$

**Activity 7**

Simplify the following and leave answers with positive exponents where necessary:

1. $\frac{27^{3-2x} \cdot 9^{x-1}}{81^{2-x}}$

2. $\frac{6.5^{x+1} - 2.5^{x+2}}{5^{x+3}}$

3. $\frac{2^{2009} - 2^{2012}}{2^{2010}}$

[13]**Solutions**

$$\begin{aligned} 1. \frac{27^{3-2x} \cdot 9^{x-1}}{81^{2-x}} &= \frac{(3^3)^{3-2x} \cdot (3^2)^{x-1}}{(3^4)^{2-x}} = \frac{3^{9-6x} \cdot 3^{2x-2}}{3^{8-4x}} \quad \checkmark \\ &= 3^{9-6x+2x-2-8+4x} \quad \checkmark \\ &= 3^{-1} = \frac{1}{3} \quad \checkmark \end{aligned} \quad (4)$$

$$\begin{aligned} 2. \frac{6.5^{x+1} - 2.5^{x+2}}{5^{x+3}} &= \frac{6.5^x \cdot 5^1 - 2.5^x \cdot 5^2}{5^x \cdot 5^3} \\ &= \frac{5^x(6 \times 5 - 2 \times 5^2)}{5^x \cdot 5^3} \quad \checkmark\checkmark \\ &= \frac{30 - 50}{125} \quad \checkmark = \frac{-20}{125} = -\frac{4}{25} \quad \checkmark \end{aligned} \quad (4)$$

$$\begin{aligned} 3. \frac{2^{2009} - 2^{2012}}{2^{2010}} &= \frac{2^{2009}(1 - 2^3)}{2^{2010}} = \frac{(2^{2009} \cdot 1 - 8)}{2^{2010}} \quad \checkmark\checkmark \\ &= \frac{2^{2009}(-7)}{2^{2010}} \\ &= 2^{2009-2010} \quad \checkmark \\ &= 2^{-1} \times -7 \quad \checkmark = \frac{1}{2} \times -7 = -\frac{7}{2} \quad \checkmark \end{aligned} \quad (5)$$

[13]

1.4 Exponential equations

Solving equations where x is part of the exponent:

- Write the powers as products of prime factors.
- Aim to get ONE power with the same base on each side of the equation.
- Equate the exponents.
- Solve for x .

e.g. 17

1. Solve for x

$$2^x = 8$$

$$2^x = 2^3$$

$$\therefore x = 3 \checkmark$$

write 8 as a power of 2
get the same base on each side
equate the exponents

2. $5^{2x+1} - 125^{2x-3} = 0$

$$5^{2x+1} = 125^{2x-3}$$

$$5^{2x+1} = (5^3)^{2x-3} \checkmark$$

$$5^{2x+1} = 5^{6x-9} \checkmark$$

$$\therefore 2x + 1 = 6x - 9$$

$$\therefore -4x = -10$$

$$\therefore x = \frac{5}{2} \checkmark \checkmark \checkmark$$

equate the two powers

write with prime bases

3. $2^x = 5^x$

$$\therefore \frac{2^x}{5^x} = 1 \quad \therefore \left(\frac{2}{5}\right)^x = 1 \checkmark$$

$$\therefore \left(\frac{2}{5}\right)^x = \left(\frac{2}{5}\right)^0 \checkmark$$

$$\therefore x = 0 \checkmark$$

4. $3^{x+1} - 3^{x-1} = 216$

$$\therefore 3^x \cdot 3^1 - 3^x \cdot 3^{-1} = 216$$

$$\therefore 3^x(3 - 3^{-1}) = 216 \checkmark \checkmark$$

$$\therefore 3^x\left(3 - \frac{1}{3}\right) = 216$$

$$\therefore 3^x\left(\frac{8}{3}\right) = 216$$

$$\therefore 3^x = 216 \times \frac{3}{8} \checkmark$$

$$\therefore 3^x = 81$$

$$\therefore 3^x = 3^4 \checkmark \quad x = 4 \checkmark$$

5. $3^{2x} - 12 \cdot 3^x + 27 = 0$

$$\therefore 3^x \cdot 3^x - 12 \cdot 3^x + 27 = 0$$

Method 1:

$$\therefore 3^x \cdot 3^x - 12 \cdot 3^x + 27 = 0$$

$$(3^x - 9)(3^x - 3) = 0 \checkmark \checkmark$$

$$3^x = 9 \quad \text{or} \quad 3^x = 3 \checkmark$$

$$3^x = 3^2 \quad \text{or} \quad 3^x = 3^1$$

$$\therefore x = 2 \checkmark \quad \text{or} \quad x = 1 \checkmark$$

Method 2:

$$\therefore 3^x \cdot 3^x - 12 \cdot 3^x + 27 = 0$$

$$\text{let } 3^x = k \therefore k \cdot k - 12k + 27 = 0$$

$$\therefore k^2 - 12k + 27 = 0 \checkmark$$

$$(k - 9)(k - 3) = 0 \checkmark$$

$$\therefore k = 9 \quad \text{or} \quad k = 3 \checkmark$$

$$\text{but } 3^x = k \therefore 3^x = 9 \quad \text{or} \quad 3^x = 3$$

$$\therefore x = 2 \checkmark \quad \text{or} \quad x = 1 \checkmark$$

[24]



Remember:
 $3^x \cdot 3^x = 3^{2x}$



Activity 8

Solve for x :

- $3(9^{x+3}) = 27^{2x-1}$
- $3^{2x-12} = 1$
- $2^x = 0,125$
- $10^{x(x+1)} = 100$
- $5^x + 5^{x+1} = 30$
- $5^{2+x} - 5^x = 5^x \cdot 23 + 1$
- $5^x + 15 \cdot 5^{-x} = 2$
- $x^{\frac{2}{3}} - x^{\frac{1}{3}} - 12 = 0$

[31]

Solutions

Remember: When adding or subtracting terms, you need to factorise first.

$$\begin{array}{ll}
 1. \quad 3(9^{x+3}) = 27^{2x-1} & 2. \quad 3^{2x-12} = 1 \\
 3^1(3^2)^{x+3} = (3^3)^{2x-1} & 3^{2x-12} = 3^0 \quad \checkmark \\
 \text{prime bases} & \text{make same bases by} \\
 & \text{putting } 1 = 3^0 \\
 3^{1+2x+6} = 3^{6x-3} \quad \checkmark & \text{same bases} & \therefore 2x - 12 = 0 \quad \checkmark \\
 \therefore 7 + 2x = 6x - 3 \quad \checkmark & \text{equate exponents} & 2x = 12 \\
 -4x = -3 - 7 & & x = 6 \quad \checkmark \\
 x = \frac{-10}{-4} = \frac{5}{2} \quad \checkmark & & (3)
 \end{array}$$

$$\begin{array}{ll}
 3. \quad 2^x = 0,125 & \text{convert to a common fraction} & 4. \quad 10^{x(x+1)} = 100 \\
 2^x = \frac{125}{1000} = \frac{1}{8} = \frac{1}{2^3} \quad \checkmark & \text{simplify} & 10^{x(x+1)} = 10^2 \\
 2^x = 2^{-3} \quad \checkmark & \text{same bases} & \therefore x(x+1) = 2 \quad \checkmark \\
 \therefore x = -3 \quad \checkmark & \text{equate exponents} & x^2 + x - 2 = 0 \\
 & (3) & \text{set quadratic equation} = 0 \\
 & & (x+2)(x-1) = 0 \quad \checkmark \\
 & & \text{factorise the trinomial} \\
 & & x+2=0 \quad \text{or} \quad x-1=0 \\
 & & x = -2 \quad \checkmark \quad x = 1 \\
 & & \checkmark & (4)
 \end{array}$$

$$\begin{array}{l}
 5. \quad 5^{2+x} - 5^x = 5^x \cdot 23 + 1 \\
 5^{2+x} - 5^x - 5^x \cdot 23 = 1 \quad \text{like terms} \\
 5^{2+x} - 24 \cdot 5^x = 1 \quad \checkmark \\
 5^2 \cdot 5^x - 24 \cdot 5^x = 1 \quad \text{factorise (Common Factor)} \\
 5^x(5^2 - 24) = 1 \quad \checkmark \checkmark \\
 5^x(1) = 1 \\
 5^x = 5^0 \quad \therefore x = 0 \quad \checkmark \\
 (4)
 \end{array}$$



When adding or subtracting terms, you need to factorise first.

$$\begin{array}{l}
 6. \quad 5^x + 5^{x+1} = 30 \\
 5^x + 5^x \cdot 5^1 = 30 \quad \text{factorise} \\
 5^x(1 + 5^1) = 30 \quad \checkmark \checkmark \quad \text{common factor } 5^x \\
 5^x(6) = 30 \quad \checkmark \quad \text{divide 30 by 6} \\
 5^x = 5 \quad \text{same bases} \\
 \therefore x = 1 \quad \checkmark \quad \text{equate exponents} \quad (4)
 \end{array}$$



$$5^{x+1} = 5^x \cdot 5$$



When adding or subtracting terms, you need to factorise first.

7. $5^x + 15 \cdot 5^{-x} = 2$

$\therefore 5^x + \frac{15}{5^x} = 2$

$\times 5^x \therefore 5^x \cdot 5^x + 5^x \cdot \frac{15}{5^x} = 2 \cdot 5^x \checkmark$

$\therefore 5^x \cdot 5^x + 15 = 2 \cdot 5^x$

$\therefore 5^x \cdot 5^x - 2 \cdot 5^x + 15 = 0 \checkmark$

$\therefore (5^x - 5)(5^x + 3) = 0 \checkmark \checkmark$

$\therefore 5^x = 5$ or $5^x = -3$ (no solution)

$\therefore x = 1 \checkmark$

hint

$5^{-x} = \frac{1}{5^x} \therefore 15 \cdot 5^{-x} = 15 \times \frac{1}{5^x} = \frac{15}{5^x}$

hint

Factorise - trinomial

(5)

8. $x^{\frac{2}{3}} - x^{\frac{1}{3}} - 12 = 0$

$\therefore (x^{\frac{1}{3}} - 4)(x^{\frac{1}{3}} + 3) \checkmark \checkmark = 0$

$\therefore x^{\frac{1}{3}} = 4$ or $x^{\frac{1}{3}} = -3 \checkmark$

$\therefore x = 64 \checkmark$ or $x = -267 \checkmark$

hint

$x^{\frac{1}{3}} \cdot x^{\frac{1}{3}} = x^{\frac{2}{3}}$

(5)

[31]

If the numerator of the exponent is odd, then we will always have one and only one solution



1.5 Equations with rational exponents

1.5.1 Tips

- When working with equations, you must do the same operation to both sides of the equation.
- Get the variable with the fraction exponent on one side by itself.
- Get x by itself by changing the fraction exponent to an exponent of 1.
- Do this by choosing an exponent for both sides, so that $x^{\frac{m}{n}}$ becomes x^1 .

e.g. 18

1. $x^{\frac{1}{2}} = 3$

(Raise both sides to the power of 3)

$(x^{\frac{1}{2}})^2 = (3)^2 \checkmark$

$\therefore x^1 = 9 \checkmark$

(Raise both sides to the power of 2)

2. $x^{\frac{1}{2}} = -3 \checkmark$

$x^1 = (x^{\frac{1}{2}})^2 = 9$

(Raise both sides to the power of $\frac{4}{3}$)

3. $x^{\frac{3}{4}} = 8$

$(x^{\frac{3}{4}})^{\frac{4}{3}} = 8^{\frac{4}{3}} \checkmark$

$x^1 = (2^3)^{\frac{4}{3}} = 2^4 = 16 \checkmark$

4. $x^{\frac{2}{3}} = 4$

$(x^{\frac{2}{3}})^{\frac{3}{2}} = \pm 4^{\frac{3}{2}} \checkmark$

$x = \pm (2^2)^{\frac{3}{2}} = \pm (2)^3 \checkmark$

$\therefore x = -8 \checkmark$ or $x = 8 \checkmark$

If the numerator of the exponent is even, then we get a quadratic equation with two possible answers.

$x^{\frac{2}{3}} = 4$

$\therefore x^{\frac{2}{3}} - 4 = 0$

$\therefore (x^{\frac{1}{3}} - 2)(x^{\frac{1}{3}} + 2) = 0$

$\therefore x^{\frac{1}{3}} = 2$ or $x^{\frac{1}{3}} = -2$

$\therefore (x^{\frac{1}{3}})^3 = 2^3$ or $(x^{\frac{1}{3}})^3 = (-2)^3$

$\therefore x = 8$ or $x = -8$

$x^{\frac{1}{2}} = -3$
 $\therefore \sqrt{x} = -3$
The square root of a negative is non-real





Activity 9

Solve for x :

1. $x^{-\frac{3}{2}} = 8$

2. $\sqrt[5]{x^4} = 256$

[7]

Solutions

1. $x^{-\frac{3}{2}} = 8$

$$(x^{-\frac{3}{2}})^{-\frac{2}{3}} = (2^3)^{-\frac{2}{3}} \quad \checkmark \checkmark \quad \text{(raise both sides to the power of } -\frac{2}{3}\text{)}$$

$$x^{+1} = 2^{-2} \quad \checkmark \quad (2)^3 \times -\frac{2}{3}$$

$$x = \frac{1}{4}$$

(3)

2. $\sqrt[5]{x^4} = 256$ (change radical to fractional exponent form)

$$x^{\frac{4}{5}} = \pm (2)^8 \quad \checkmark \quad \text{(raise both sides of equation to the power of } \frac{5}{4}\text{)}$$

$$(x^{\frac{4}{5}})^{\frac{5}{4}} = \pm (2^8)^{\frac{5}{4}} \quad \checkmark$$

$$\therefore x = \pm (2)^{10} \quad \checkmark = \pm 1024 \quad \checkmark$$

(4)

[7]

The numerator of the exponent is even, therefore two solutions are possible.

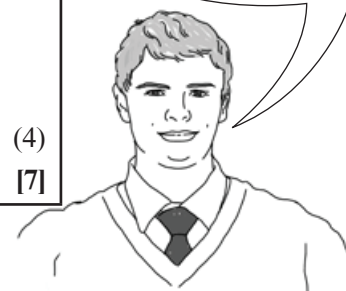

1.5.2 Exponential equations with surds

e.g. 19

Solve for x :

$3\sqrt{x+2} + x = 2$

[7]

Solution

$$3\sqrt{x+2} + x = 2$$

$$\therefore 3\sqrt{x+2} = 2 - x$$

$$\therefore (3\sqrt{x+2})^2 = (2-x)^2 \quad \checkmark$$

$$\therefore 9(x+2) = (2-x)(2-x) \quad \checkmark$$

$$\therefore 9x + 18 = 4 - 4x + x^2 \quad \checkmark$$

$$\therefore 0 = x^2 - 13x - 14 \quad \checkmark$$

$$\therefore 0 = (x-14)(x+1) \quad \checkmark$$

$$\therefore x = 14 \text{ or } x = -1 \quad \checkmark$$

Check:

$$x = 14 \quad LHS = 3\sqrt{14+2} + 14 = 3\sqrt{16} + 14 = 3 \times 4 + 14 = 26 \quad RHS = 2$$

$$\therefore x = 14 \text{ is not a solution} \quad \checkmark$$

$$x = -1 \quad LHS = 3\sqrt{-1+2} + (-1) = 3\sqrt{1} - 1 = 3 \times 1 - 1 = 2 \quad RHS = 2$$

$$\therefore x = -1 \text{ is a solution}$$

[7]



Activity 10

Solve these equations and check your solutions.

1. $\sqrt{3x+4} - 5 = 0$ (3)

2. $\sqrt{3x-5} - x = 5$ (5)

[8]

Solutions

1. $\sqrt{3x+4} - 5 = 0$

$\sqrt{3x+4} = 5$ (isolate the radical)

$(\sqrt{3x+4})^2 = 5^2$ ✓ (square both sides of the equation)

$3x+4 = 25$ ✓

$3x = 21$

$x = 7$ ✓

Check:

LHS: $\sqrt{3(7)+4} - 5$

$= \sqrt{21+4} - 5$

$= \sqrt{25} - 5$

$= 0$

$= \text{RHS}$

$\therefore x = 7$ is a solution (3)

2. $\sqrt{3x-5} - x = 5$

$\sqrt{3x-5} = x+5$

$(\sqrt{3x-5})^2 = (x+5)^2$ ✓

$3x-5 = x^2+10x+25$ ✓

$0 = x^2+7x+30$ ✓

$0 = (x+10)(x+3)$ ✓

$x = -10$ or $x = -3$

(always isolate the radical first)

(square both sides)

Remember: $(x+5)^2 \neq x^2+25$

(quadratic equation, set = 0)

(factorise the trinomial and make each factor = 0)

Check your answer:

If $x = 10$

LHS:

$\sqrt{3(10)-5} - 10$

$= \sqrt{25} - 10$

$= -5 = \text{RHS}$

$\therefore x = 10$ is a solution. ✓

If $x = 3$

LHS

$\sqrt{3(3)-5} - 3$

$= \sqrt{4} - 3$

$= -1 \neq \text{RHS}$

(5)

[8]

1.6 Exam type examples



Activity 11

1. Simplify the following:

a) $\frac{6^{6x} \cdot 9^{3x}}{54^{4x} \cdot \left(\frac{1}{4}\right)^{2-x}}$

b) $\frac{2^{2x+2} - 2^{2x-1}}{4^x + 8 \cdot 2^{2x-4}}$

2. Solve for x :

a) $3^x - 3^{x-1} = 6$

b) $4^{(x+1)(x-3)} = 8^{-x}$

c) $2^{2x} - 3 \times 2^x - 4 = 0$

[22]

Solutions

$$\begin{aligned} \text{a) } \frac{6^{6x} \cdot 9^{3x}}{54^{4x} \cdot \left(\frac{1}{4}\right)^{2-x}} &= \frac{(2 \times 3)^{6x} \cdot (3^2)^{3x}}{(2 \times 3^3)^{4x} (2^{-2})^{2-x}} \checkmark = \frac{2^{6x} \times 3^{6x} \times 3^{6x}}{2^{4x} \times 3^{12x} \times 2^{-4+2x}} \checkmark \\ &= \frac{2^{6x} \times 3^{6x} \times 3^{6x}}{2^{4x} \times 3^{12x} \times 2^{-4+2x}} \checkmark \\ &= 2^4 \times 3^0 = 16 \checkmark \end{aligned} \quad (5)$$

$$\begin{aligned} \text{b) } \frac{2^{2x+2} - 2^{2x-1}}{4^x + 8 \cdot 2^{2x-4}} &= \frac{2^{2x} \cdot 2^2 - 2^{2x} \cdot 2^{-1}}{2^{2x} + 2^3 \cdot 2^{2x-4}} \checkmark \\ &= \frac{2^{2x}(2^2 - 2^{-1})}{2^{2x}(1 + 2^3 \cdot 2^{-4})} \checkmark \\ &= \frac{2^{2x}\left(2^2 - \frac{1}{2}\right)}{2^{2x}\left(1 + \frac{2^3}{2^4}\right)} \\ &= \frac{4 - \frac{1}{2}}{1 + \frac{1}{2}} \checkmark = \left(\frac{8-1}{2}\right) \div \left(\frac{2+1}{2}\right) \\ &= \left(\frac{7}{2}\right) \div \left(\frac{3}{2}\right) = \frac{7}{2} \times \frac{2}{3} = \frac{7}{3} \checkmark \end{aligned} \quad (4)$$

$$\begin{aligned} \text{2. a) } 3^x - 3^{x-1} &= 6 \\ 3^x - 3^x \cdot 3^{-1} &= 6 \\ 3^x(1 - 3^{-1}) &= 6 \checkmark \checkmark \\ 3^x\left(1 - \frac{1}{3}\right) &= 6 \checkmark \\ 3^x\left(\frac{2}{3}\right) &= 6 \\ 3^x &= 6 \times \frac{3}{2} \\ 3^x &= 9 \\ 3^x &= 3^2 \therefore x = 2 \checkmark \quad (4) \end{aligned} \quad \begin{aligned} \text{b) } 4^{(x+1)(x-3)} &= 8^{-x} \\ 4^{x^2-2x-3} &= (2^3)^{-x} \\ (2^2)^{x^2-2x-3} &= 2^{-3x} \checkmark \\ 2^{2x^2-4x-6} &= 2^{-3x} \\ \therefore 2x^2 - 4x - 6 &= -3x \checkmark \\ \therefore 2x^2 - x - 6 &= 0 \checkmark \\ \therefore (2x+3)(x-2) &= 0 \checkmark \\ \therefore x &= -\frac{3}{2} \text{ or } x = 2 \checkmark \end{aligned} \quad (5)$$

$$\begin{aligned} \text{c) } 2^{2x} - 3 \times 2^x - 4 &= 0 \\ (2^x - 4)(2^x + 1) &\checkmark \checkmark = 0 \\ \therefore 2^x &= 4 \text{ or } 2^x = -1 \text{ (no solution)} \checkmark \\ \therefore x &= 2 \checkmark \end{aligned} \quad (4)$$

[22]

What you need to be able to do:

- Use the laws of exponents to simplify expressions
- Calculate with negative powers
- Multiply and divide powers
- Add and subtract powers
- Solve exponential equations, including those with rational exponents
- Simplify surds and do operations with surds
- Rationalise the denominator if necessary
- Solve equations involving surds.



Feb/March 2014 Q 1.1.3
Nov 2013 Q 1.3
Feb/March 2013 Q 1.1.3
Feb/March 2011 Q 1.3
Nov 2010 Q1.3
Feb/March 2010 Q1.4



Algebra

2.1 Algebraic expressions

Algebraic expressions are made up of constants, variables and number operations (add, subtract, divide and multiply).

The variables are shown with letters such as x , y , a , b , p , m , n , etc.

The terms in an algebraic expression are separated by a plus or a minus sign.

e.g. 1

- $2x + 3y$ is an algebraic expression with two terms which are $2x$ and $3y$.
- $2x(3y)$ is only one term.
- $(2x + 3y)(2x - 3y)$ is also only one term because it is two expressions in brackets multiplied together. The brackets are not separated by $+$ or $-$.
- $\sqrt{2x - 3}$ is also an algebraic expression with one term because square roots can be written as exponents. $\sqrt{2x - 3} = (2x - 3)^{\frac{1}{2}}$

2.2 Addition and subtraction

Check that you know these facts:

- We can add or subtract like terms.
- If the terms are like, we add or subtract the coefficients.
- Like terms have the same variables (letters) and the variables must have the same exponents.

e.g. 2

$$3x + 5x = 8x$$

$$-3a + 10a = 7a$$

$$6x^2y + 3x - 10x^2y = -4x^2y + 3x$$

$$\frac{a}{b} + \frac{c}{d} = \frac{ad + cb}{bd}$$

We cannot add or subtract unlike terms.

2.3 Multiplication and division

Dividing by $\frac{c}{d}$ is the same as multiplying by $\frac{d}{c}$.



Check that you know these facts:

positive number \times positive number = positive answer. $3x \times 5y^2 = 15xy^2$
 positive number \times negative number = negative answer. $3x \times -5y^2 = -15xy^2$
 negative number \times positive number = negative answer. $-3x \times 5y^2 = -15xy^2$
 negative number \times negative number = positive answer. $-3x \times -5y^2 = 15xy^2$

$$\frac{a}{b} \times \frac{c}{d} = \frac{ac}{bd}$$

e.g. 3

$$\frac{6x}{7y} \times \frac{3}{5z} = \frac{18x}{35yz}$$

e.g. 4

$$\frac{6x}{8y} + \frac{3}{12z} = \frac{6x3z + 3(2y)}{24yz} = \frac{18xz + 6y}{24yz}$$

$$\checkmark \frac{a}{b} \div \frac{c}{d} = \frac{a}{b} \times \frac{d}{c} = \frac{ad}{bc}$$

The distributive law:

$$c(a + b) = c \times a + c \times b = ac + bc$$

e.g. 5

$$-3x(5x - 6y) = -15x^2 + 18xy$$

$$\begin{array}{c} \text{F} \quad \text{L} \\ (x + y)(a + b) = ax + bx + ay + by \\ \text{O} \quad \text{I} \end{array}$$

e.g. 6

$$(2x + y)(3x - 2y) = 6x^2 - 4xy + 3xy - 2y^2 = 6x^2 - xy - 2y^2$$



Multiply numerators and multiply denominators. Simplify if possible.



Find the lowest common multiple or denominator (LCM) first. 8 and 12 have an LCM of 24.

2.4 Factorising

What does it mean to 'factorise an expression'?

It means to write the expression as a product of its factors.

e.g. 7

Here are ways to factorise an expression:

1. Find the **common factor**:

$$9x^2 - 6xy^2 = 3x(3x - 2y^2)$$

2. Factorise by **grouping in pairs and then finding a common factor**:

$$3xy - 2x + 3y - 2$$

$$= 3xy + 3y - 2x - 2$$

$$= 3y(x + 1) - 2(x + 1)$$

When you take out a negative factor, signs in bracket change.

$$= (x + 1)(3y - 2)$$

3. Factorise a **difference of two squares**:

$$16x^2 - y^2 = (4x - y)(4x + y)$$

4. Factorise a **difference of two cubes**:

$$8x^3 - y^3 = (2x - y)(4x^2 + 2xy + y^2)$$

5. Factorise a **sum of two cubes**:

$$27a^3 + 64b^3 = (3a + 4b)(9a^2 - 12ab + 16b^2)$$

6. Factorise a **trinomial**:

$$9x^2 + 5x - 4 = (9x - 4)(x + 1)$$

It is useful to use 'FOIL' (multiply **FIRST** terms, **OUTER** terms, **INNER** terms and **LAST** terms).



hint

When factorising, always take out a common factor first, if possible. Then look to factorise the difference of two squares or the sum/difference of two cubes or a trinomial.

2.5 Notes on factorising a trinomial

The following steps will explain how to factorise a trinomial:

e.g. 8 Factorise $3x^2 + 11x + 6$

Step 1: Multiply the coefficient of x^2 and the constant value ($+3 \times +6 = 18$).

Step 2: Write down all the products of 18: 10×1
 9×2
 6×3

Step 3: We will use 9×2 , because $9 + 2 = 11$, the middle term.

Step 4: We write the middle term ($11x$) as $9x + 2x$
 $\therefore 3x^2 + 11x + 6$
 $= 3x^2 + 9x + 2x + 6$we wrote the $9x$ first, followed by the $2x$

Step 5: We now group the four terms and factorise by taking out a common factor.
 $3x^2 + 9x + 2x + 6$
 $= 3x(x + 3) + 2(x + 3)$
 $= (x + 3)(3x + 2)$

e.g. 9 Factorise $4x^2 + 9x - 13$

Step 1: Multiply the coefficient of x^2 and the constant value ($+4 \times -13 = -52$).

Step 2: Write down all the products of 52: 52×1
 26×2
 13×4

Step 3: We will use 13×4 , because $13 - 4 = 9$, the middle term.

Step 4: We write the middle term ($9x$) as $-4x + 13x$
 $\therefore 4x^2 + 9x - 13$
 $= 4x^2 - 4x + 13x - 13$we write the $-4x$ first, followed by the $13x$

Step 5: We now group the four terms and factorise by taking out a common factor.
 $4x^2 - 4x + 13x - 13$
 $= 4x(x - 1) + 13(x - 1)$
 $= (x - 1)(4x + 13)$

e.g. 10 Factorise $8x^2 - 18x + 9$

Step 1: Multiply the coefficient of x^2 and the constant value ($+8 \times +9 = 72$).

Step 2: Write down all the products of 72: 72×1
 36×2
 24×3
 18×4
 12×6
 9×8



We write the $9x$ first and the $2x$ second because: There is a common factor between $3x^2$ and $9x$.
 There is a common factor between $2x$ and 6 .



We write the $-4x$ first and the $13x$ second because:
 There is a common factor between $4x^2$ and $-4x$. There is a common factor between $13x$ and -13 .

Step 3: We will use 12×6 , because $-12 - 6 = -18$, the middle term.

Step 4: We write the middle term ($-18x$) as $-12x - 6x$ or $-6x - 12x$
 $\therefore 8x^2 - 18x + 9$
 $= 8x^2 - 12x - 6x + 9$we write the $-4x$ first followed by the $13x$

Step 5: We now group the four terms and factorise by taking out a common factor

$$\begin{aligned} & 8x^2 - 12x - 6x + 9 \\ & = 4x(2x - 3) - 3(2x - 3) \\ & = (2x - 3)(4x - 3) \end{aligned}$$



In this example, we can write $-12x$ first and then $-6x$ or $-6x$ first and then $-12x$. We have a common factor between $8x^2$ and $-12x$ and between $-12x$ and 9 . We have a common factor between $8x^2$ and $-6x$ and between $-6x$ and 9 .



Activity 1

Factorise each of the following completely:

1. $12x^2 + 17x + 6$
2. $5x^2 - 23x - 10$
3. $9x^2 + 5x - 4$
4. $12x^2 - 11x + 2$
5. $5x^2 - 45$
6. $2x^3 + 16$
7. $6x^3 - 13x^2 + 5x$

[16]

Solutions

$$\begin{aligned} 1. \quad & 12x^2 + 17x + 6 \\ & = 12x^2 + 9x + 8x + 6 \dots\dots\dots 12 \times 6 = 72 \text{ and } 72 = 9 \times 8 \text{ (} 9 + 8 = 17 \text{)} \\ & = 3x(4x + 3) + 2(4x + 3) \\ & = (4x + 3)(3x + 2) \checkmark \checkmark \end{aligned} \quad (2)$$

$$\begin{aligned} 2. \quad & 5x^2 - 23x - 10 \\ & = 5x^2 - 25x + 2x - 10 \dots\dots\dots 5 \times -10 = -50 \text{ and } 50 = 25 \times 2 \text{ (} -25 + 2 = -23 \text{)} \\ & = 5x(x - 5) + 2(x - 5) \\ & = (x - 5)(5x + 2) \checkmark \checkmark \end{aligned} \quad (2)$$

$$\begin{aligned} 3. \quad & 9x^2 + 5x - 4 \\ & = 9x^2 + 9x - 4x - 4 \dots\dots\dots 9 \times -4 = -36 \text{ and } 36 = 9 \times 4 \text{ (} 9 - 4 = 5 \text{)} \\ & = 9x(x + 1) - 4(x + 1) \\ & = (x + 1)(9x - 4) \checkmark \checkmark \end{aligned} \quad (2)$$

$$\begin{aligned} 4. \quad & 12x^2 - 11x + 2 \\ & = 12x^2 - 3x - 8x + 2 \dots\dots\dots 12 \times 2 = 24 \text{ and } 24 = 8 \times 3 \text{ (} -8 - 3 = -11 \text{)} \\ & = 3x(4x - 1) - 2(4x - 1) \\ & = (4x - 1)(3x - 2) \checkmark \checkmark \end{aligned} \quad (2)$$

$$\begin{aligned} 5. \quad & 5x^2 - 45 \dots\dots\dots \text{Common factor of } 5 \\ & = 5(x^2 - 9) \dots\dots\dots \text{Difference of two squares} \\ & = 5(x - 3)(x + 3) \checkmark \checkmark \end{aligned} \quad (2)$$

$$\begin{aligned} 6. \quad & 2x^3 + 16 \dots\dots\dots \text{Common factor of } 2 \\ & = 2(x^3 + 8) \checkmark \dots\dots\dots \text{Sum of two cubes} \\ & = 2(x + 2)(x^2 - 2x + 4) \checkmark \checkmark \end{aligned} \quad (3)$$

$$\begin{aligned} 7. \quad & 6x^3 - 13x^2 + 5x \dots\dots\dots \text{Common factor of } x \\ & = x(6x^2 - 13x + 5) \checkmark \dots\dots\dots \text{Trinomial factorising} \\ & = x(6x^2 - 3x - 10x + 5) \dots\dots\dots 6 \times 5 = 30 \text{ and } 30 = 10 \times 3 \text{ (} -3 - 10 = -13 \text{)} \\ & = x[3x(2x - 1) - 5(2x - 1)] \\ & = x[(2x - 1)(3x - 5)] \checkmark \checkmark \end{aligned} \quad (3)$$

[16]

2.6 Quadratic equations

e.g. 11

Here are some quadratic equations:

- $x^2 + 5x + 6 = 0$
- $3x^2 - 7x = 12$
- $3x(x - 9) + 2 = 5x$ $3x \times x = 3x^2$ so the equation has x^2 as its highest power of x

Quadratic equations can be put into the standard form: $ax^2 + bx + c = 0$

e.g. 12

- $x^2 + 5x + 6 = 0$ So $a = 1$, $b = 5$ and $c = 6$
- $3x^2 - 4x = 12$
 $3x^2 - 4x - 12 = 0$ So $a = 3$, $b = -4$ and $c = -12$
- $3x(x - 9) + 2 = 5x$
 $3x^2 - 27x + 2 - 5x = 0$
 $3x^2 - 32x + 2 = 0$ So $a = 3$, $b = -32$ and $c = 2$

If $(A) \times (B) = 0$, then
either $A = 0$
OR $B = 0$.



2.6.1 Solving a quadratic equation by factorising:

What does it mean to 'solve a quadratic equation'?

It means to find the unknown value(s) of x in a quadratic equation. The x -values in a quadratic equation are also called the **roots** of the equation when the equation is equal to zero.

e.g. 13

Solve for x :

$$x^2 - 7x = -10$$

$$x^2 - 7x + 10 = 0$$

$$x^2 - 5x - 2x + 10 = 0$$

$$x(x-5) - 2(x-5) = 0$$

$$(x-5)(x-2) = 0$$

$$\therefore x - 5 = 0 \text{ or } x - 2 = 0$$

$$x = 5 \quad \therefore x = 2$$

Write in standard form and equal to 0

Factorise the trinomial



Activity 2

Solve for x :

$$1. \quad x(x + 3) = 0$$

$$2. \quad x(2x - 5) = 12$$

$$3. \quad 2x^2 + x - 6 = 0$$

$$4. \quad 2x^2 = 32$$

$$5. \quad 3x + \frac{1}{x} = 4, \quad x \neq 0$$

$$6. \quad 2\sqrt{x-3} = x-3$$

[22]

Solutions

1. $x(x + 3) = 0$
 $x = 0$ or $x + 3 = 0$
 $x = 0$ ✓ or $x = -3$ ✓ (2)

We have a product = 0. Therefore put each factor = 0

2. $x(2x - 5) = 12$
 $(2x + 3)(x - 4) = 0$
 $2x + 3 = 0$ or $x - 4 = 0$
 $2x = -3$ or $x = 4$
 $x = -\frac{3}{2}$ ✓ $x = 4$ ✓ (2)

We need a product = 0. Therefore, multiply out brackets and write in standard form with all the terms on one side and equal to 0

Factorise

Put each factor = 0

3. $2x^2 + x - 6 = 0$
 $(2x - 3)(x + 2) = 0$ ✓✓
 $\therefore 2x = 3$ or $x = -2$
 $\therefore x = \frac{3}{2}$ or $x = -2$ ✓✓ (4)

Find the solutions by putting each factor equal to zero

4. $2x^2 = 32$
 $2x^2 - 32 = 0$
 $x^2 - 16 = 0$ ✓
 $(x + 4)(x - 4) = 0$ ✓
 $\therefore x + 4 = 0$ or $x - 4 = 0$
 $\therefore x = -4$ ✓ or $\therefore x = 4$ ✓ (4)

Write in standard form with all the terms on one side and equal to 0

Divide every term on both sides by 2

Factorise (the difference of two squares)

5. $3x + \frac{1}{x} = 4, x \neq 0$
 $3x^2 + 1 = 4x$
 $3x^2 - 4x + 1 = 0$ ✓
 $(3x - 1)(x - 1) = 0$ ✓✓
 $\therefore 3x - 1 = 0$ or $x - 1 = 0$
 $\therefore 3x = 1$ or $x = 1$
 $\therefore x = \frac{1}{3}$ ✓ or $\therefore x = 1$ ✓ (5)

Multiply through by x to get rid of the denominator

Write in standard form with all the terms on one side and equal to 0

Factorise (the trinomial)

6. $2\sqrt{x-3} = x-3$
 $(2\sqrt{x-3})^2 = (x-3)^2$
 $4(x-3) = (x-3)(x-3)$ ✓
 $4x - 12 = x^2 - 6x + 9$
 $0 = x^2 - 10x + 21$ ✓
 $0 = (x-7)(x-3)$ ✓
 $\therefore x-7 = 0$ or $x-3 = 0$
 $\therefore x = 7$ ✓ or $x = 3$ ✓ (5)

Square both sides

[22]

Check your answers:

$$x = 7$$

$$\text{LHS} = 2\sqrt{7-3} = 2\sqrt{4} = 2(2) = 4 \quad \text{RHS} = 7 - 3 = 4 \quad \therefore x = 7 \text{ is a solution}$$

$$x = 3$$

$$\text{LHS} = 2\sqrt{3-3} = 2\sqrt{0} = 0 \quad \text{RHS} = 3 - 3 = 0 \quad \therefore x = 3 \text{ is a solution}$$

If a quadratic equation cannot be factorised, there are other ways to find the roots or solutions. Sometimes the solutions do not exist!

2.6.2 Completing the square

e.g. 14

Write $y = 3x^2 + 12x + 9$ in the form $y = a(x + p)^2 + q$.

To do this, we can follow a few steps:

$$y = 3x^2 + 12x + 9$$

To complete the square, the coefficient of x^2 must be one (1). We take 3 out as a factor so that the coefficient of x^2 is one.

$$y = 3[x^2 + 4x + 3]$$

Take (half of the coefficient of x) and square the number. Add and subtract this answer to keep the equation balanced.

The coefficient of x is +4.
Halving 4 = 2. $(+2)^2 = 4$.

$$y = 3[x^2 + 4x + (+2)^2 + 3 - (+2)^2]$$

Thus, add 4 and subtract 4.

$$\begin{aligned} y &= 3[x^2 + 4x + 4 + 3 - 4] \\ &= 3[\underbrace{x^2 + 4x + (+2)^2}_{(x + 2)^2} + 3 - 4] \end{aligned}$$

Now we can complete the square by factorising

$$y = 3[(x + 2)^2 + 3 - 4]$$

$$y = 3[(x + 2)^2 - 1]$$

$$y = 3(x + 2)^2 - 3$$

We have now written $y = 3x^2 + 12x + 9$ as $y = 3(x + 2)^2 - 3$. Therefore, we have written

$y = ax^2 + bx + c$ in the form $y = a(x + p)^2 + q$ with $a = 3$, $p = 2$ and $q = -3$.

The quadratic equation $y = 3x^2 + 12x + 9$ helps us to identify the **y-intercept**, while the form $y = 3(x + 2)^2 - 3$ helps us to identify the **turning point**. Refer to graphs in unit 4 on **Functions**.



Activity 3

- What term can be added to the following equations to make a complete square?
 - $0 = x^2 - 8x + ?$
 - $y = x^2 + 9x + ?$
 - $y = x^2 - \frac{b}{a}x + ?$
- Solve for x by using the method of completing the square.
 - $-3x^2 + 5x + 4 = 0$
 - $ax^2 + bx + c = 0$

[17]

Solutions

1a) $0 = x^2 - 8x + (-4)^2$

$$0 = x^2 - 8x + 16$$

$$0 = (x - 4)^2 \quad \checkmark$$

Use half of -8 squared

b) $y = x^2 + 9x + \left(\frac{9}{2}\right)^2$

$$y = x^2 + 9x + \frac{81}{4}$$

$$y = \left(x + \frac{9}{2}\right)^2 \quad \checkmark\checkmark (2)$$

c) $y = x^2 - \frac{b}{a}x + ?$

$$y = x^2 - \frac{b}{a}x + \left(-\frac{b}{2a}\right)^2 = x^2 - \frac{b}{a}x + \frac{b}{a}$$

$$y = \left(x - \frac{b}{2a}\right)^2 \quad \checkmark\checkmark (2)$$

Use half of $-\frac{b}{a}$ squared

2a) $-3x^2 + 5x + 4 = 0$

$$x^2 - \frac{5}{3}x - \frac{4}{3} = 0$$

$$x^2 - \frac{5}{3}x = \frac{4}{3} \quad \checkmark$$

$$x^2 - \frac{5}{3}x + \left(\frac{5}{6}\right)^2 = \frac{4}{3} + \left(\frac{5}{6}\right)^2 \quad \checkmark$$

$$\left(x - \frac{5}{6}\right)^2 \checkmark = \frac{4}{3} + \frac{25}{36}$$

$$\left(x - \frac{5}{6}\right)^2 = \frac{48 + 25}{36}$$

$$\left(x - \frac{5}{6}\right)^2 = \frac{73}{36} \quad \checkmark$$

$$x - \frac{5}{6} = \pm \sqrt{\frac{73}{36}}$$

$$x = \frac{5}{6} \pm \frac{\sqrt{73}}{6}$$

$$x = \frac{5}{6} + \frac{\sqrt{73}}{6} \text{ or } x = \frac{5}{6} - \frac{\sqrt{73}}{6} \quad \checkmark\checkmark (6)$$

$$x = 2,2573\dots \text{ or } x = -0,5906\dots$$

$$\therefore x = 2,26 \text{ or } x = -0,59$$

These are the roots of the equation.

Divide each term on both sides by -3

Get the constant value on its own on RHS

Add $(\frac{1}{2}$ coefficient of x term) 2 to both sides

Complete the square by factorising the LHS

Add the constant values on RHS

Take the square root of both sides

Get x on its own

Separate the two values of the square root

Use a calculator to get each value

Rounded off to two decimal places

Divide each term on both sides by a

Get the constant term on its own

Add $(\frac{1}{2}$ coefficient of x term) 2 to both sides

This complete a perfect square on LHS

Add the constant values on RHS

$$\sqrt{\left(x + \frac{b}{2a}\right)^2} = \pm \sqrt{\frac{b^2 - 4ac}{4a^2}}$$

$$\therefore x + \frac{b}{2a} = \pm \sqrt{\frac{b^2 - 4ac}{4a^2}}$$

$$\therefore x = -\frac{b}{2a} \pm \sqrt{\frac{b^2 - 4ac}{4a^2}}$$

$$\therefore x = -\frac{b \pm \sqrt{b^2 - 4ac}}{2a} \quad \checkmark\checkmark (6)$$

Take square root of both sides

Get x on its own

Write the two fractions as one fraction

[17]

$\therefore x = \frac{-b \pm \sqrt{b^2 - 4ac}}{2a}$
is the formula that we use to solve any quadratic equation, $y = ax^2 + bx + c$ where a = coefficient of x^2 , b = coefficient of x and c = constant value/term.



2.6.3 Solving quadratic equations using the formula

Some quadratic equations cannot be factorised, but there is another way to find the roots of the equation.

e.g. 15

Can you find factors for this quadratic equation: $x^2 - 5x + 3 = 0$?

There are no rational numbers that can be multiplied to get 3 and added to get 5,

therefore use the quadratic formula to solve the equation.

The standard form of the quadratic equation $ax^2 + bx + c = 0$ is used from which the formula is derived:

$$x = \frac{-b \pm \sqrt{b^2 - 4ac}}{2a}$$

For $x^2 - 5x + 3 = 0$ $a = 1$, $b = -5$ and $c = 3$

Substitute these values for a , b and c in the formula:

$$x = \frac{-(-5) \pm \sqrt{(-5)^2 - 4(1)(3)}}{2(1)}$$

$$x = \frac{5 \pm \sqrt{25 - 12}}{2}$$

$$x = \frac{5 \pm \sqrt{13}}{2}$$

$$x = \frac{5 + \sqrt{13}}{2} \quad \text{OR} \quad x = \frac{5 - \sqrt{13}}{2}$$



Activity 4: Interpret a graph

Solve for x (correct to two decimal places):

$$4x^2 - 8x = 7$$

$$2x(3x + 5) - 11 = 0$$

[9]

Solutions

1. $4x^2 - 8x = 7$

$$4x^2 - 8x - 7 = 0$$

$$a = 4; b = -8; c = -7$$

$$x = \frac{-b \pm \sqrt{b^2 - 4ac}}{2a}$$

$$x = \frac{-(-8) \pm \sqrt{(-8)^2 - 4(4)(-7)}}{2(4)} \checkmark \checkmark$$

$$x = \frac{8 \pm \sqrt{176}}{8}$$

$$x = \frac{8 + \sqrt{176}}{8} \text{ or } x = \frac{8 - \sqrt{176}}{8} \checkmark$$

$$x = 2,66 \checkmark \text{ or } x = -0,66 \checkmark$$

Write the equation in standard form

$$(ax^2 + bx + c = 0)$$

List the values of a , b and c

Write down the formula

Substitute the values for a , b and c into the formula.

Simplify the value under the square root sign

Separate the positive and negative value of the square root

Answers in surd form

Answers correct to two decimal places (5)

2. $2x(3x + 5) - 11 = 0$

$$6x^2 + 10x - 11 = 0 \quad (ax^2 + bx + c = 0)$$

$$x = \frac{-10 \pm \sqrt{100 + 264}}{12} \checkmark \checkmark$$

$$= -10 \pm \frac{\sqrt{364}}{12} \checkmark$$

$$= \frac{-5 \pm \sqrt{91}}{6} \checkmark$$

Write the equation in standard form

(4)

[9]



These roots are irrational. Unless the question asks for decimal values, leave them in surd form (the square root form).

e.g. 16

If $\frac{2}{3}$ is a root of the equation $12x^2 - kx - 8 = 0$, determine the value of k .

Solution

If $\frac{2}{3}$ is a root of the equation, then $x = \frac{2}{3}$. Therefore, we can substitute $x = \frac{2}{3}$ into the equation:

$$12x^2 - kx - 8 = 0$$

$$\therefore 12\left(\frac{2}{3}\right)^2 - k\left(\frac{2}{3}\right) - 8 = 0$$

$$\frac{16}{3} - \frac{2}{3}k - 8 = 0$$

$$\therefore -\frac{2}{3}k = \frac{8}{3}$$

$$\therefore k = -4$$

2.7 Quadratic inequalities

Solving quadratic

To solve quadratic inequalities

- Get the inequality into the standard form $ax^2 + bx + c > 0$ or $ax^2 + bx + c < 0$ or $ax^2 + bx + c \leq 0$ or $ax^2 + bx + c \geq 0$
- If the value of $a < 0$, multiply the equation by -1 .
- Factorise the inequality when this is possible or
- use the quadratic formula to obtain the critical values.

If we multiply an inequality by a negative, the inequality sign swaps:
If $-5 < 7$, then after being multiplied by (-1) ,
 $\therefore 5 > -7$



e.g. 17 Solve for x if $x^2 < 25$

Method 1

$$x^2 < 25$$

$$x^2 - 25 < 0$$

$$(x - 5)(x + 5) < 0$$

The critical values are where the expression $x^2 - 25$ is equal to zero. Therefore the critical values are -5 and 5 .

We now indicate -5 and 5 on a number line.



We know that the expression $x^2 - 25 = 0$ at -5 and 5 . We can indicate this on the number line.

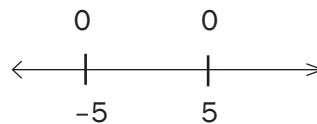

Our next step is to choose values less than -5 , values between -5 and 5 and values greater than 5 and substitute it into the expression $x^2 - 25$. If the answer is positive, then we indicate $+$ on the number line. If the answer is negative, we indicate $-$ on the number line.

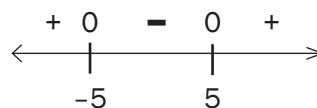

We have to solve for x where $x^2 - 25 < 0$. The solution on the number line is the interval where we see a negative. This happens between -5 and 5 .

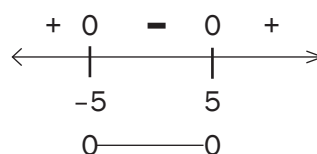

Therefore the solution is : $-5 < x < 5$

hint

If $x = -10$,
then $(-10)^2 - 25 = 75 > 0 \therefore +$

If $x = -6$,
then $(-6)^2 - 25 = 11 > 0 \therefore +$

If $x = -3$,
then $(-3)^2 - 25 = -16 < 0 \therefore -$

If $x = 2$,
then $(2)^2 - 25 = -21 < 0 \therefore -$

If $x = 7$,
then $(7)^2 - 25 = 24 > 0 \therefore +$

If $x = 9$,
then $(9)^2 - 25 = 56 > 0 \therefore +$

OR ALTERNATIVE METHOD by using a rough sketch of the parabola:

Above the x -axis y is positive

On the x -axis y is zero

Below the x -axis y is negative

e.g. 18 Solve for x if $x^2 < 25$

$$x^2 < 25$$

$$x^2 - 25 < 0$$

$$(x - 5)(x + 5) < 0$$

Critical values of x : -5 and 5

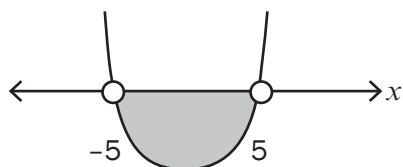

$$-5 < x < 5$$

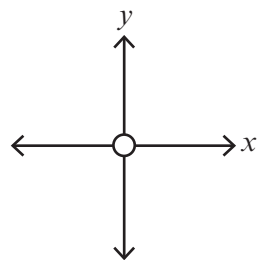

Get 0 on RHS
Factorise LHS

Make a rough sketch of a parabola

If $(***)(***) < 0$ (it means where y is negative)

Read off the x values of the graph under the x -axis

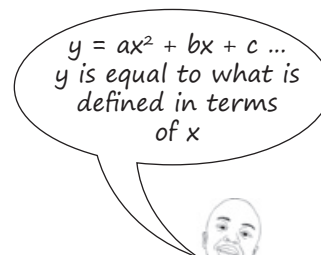

Activity 5

Solve for x if

1. $(x+3)(x-5) \leq -12$

2. $-x \leq 2x^2 - 3$

[10]

Solutions

1. $(x+3)(x-5) \leq -12$

$$x^2 - 2x - 15 + 12 \leq 0 \quad \text{Get into the standard form } (ax^2 + bx + c \leq 0)$$

$$x^2 - 2x - 3 \leq 0 \quad \checkmark$$

Factorise the trinomial:

$$(x - 3)(x + 1) \leq 0 \quad \checkmark$$

Critical values:

$$x = 3 \text{ and } x = -1$$

We now indicate 3 and -1 on a number line.

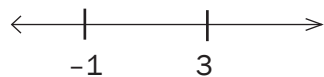

We know that the expression $x^2 - 2x - 3 = 0$ at $x = 3$ and $x = -1$. We can indicate this on the number line.

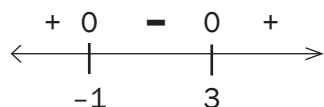

hint

If $x = -10$, then $(-10)^2 - 2(-10) - 3 = 117 > 0 \therefore +$
 If $x = 1$, then $(1)^2 - 2(1) - 3 = -4 < 0 \therefore -$
 If $x = 5$, then $(5)^2 - 2(5) - 3 = 12 > 0 \therefore +$

Whenever we multiply or divide an inequality by a negative, the inequality sign changes i.e. the less or equal to sign changes to a greater or equal to sign.



hint

If $x = -10$, then $2(-10)^2 + (-10) - 3 = 187 > 0 \therefore +$
 If $x = 0$, then $2(0)^2 - 0 - 3 = -3 < 0 \therefore -$
 If $x = 3$, then $2(3)^2 + 3 - 3 = 18 > 0 \therefore +$

Our next step is to choose values less than -1 , values between -1 and 3 and values greater than 3 and substitute it into the expression $x^2 - 2x - 3$. If the answer is positive, then we indicate $+$ on the number line. If the answer is negative, we indicate $-$ on the number line

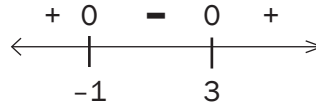

We have to solve for x where $x^2 - 2x - 3 \leq 0$. The solution on the number line is the interval where we see zero and a negative. This happens when the x values are less than or equal to 3 and are also more than or equal to -1 .

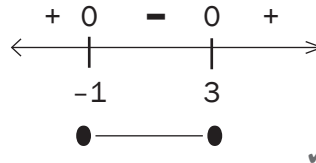

Therefore the solution is : $-1 \leq x \leq 3$ ✓✓ (5)

2. $-x \leq 2x^2 - 3$

$-2x^2 - x + 3 \leq 0$

$\frac{-2x}{-1} - \frac{x}{-1} + \frac{3}{-1} \geq \frac{0}{-1}$

$2x^2 + x - 3 \geq 0$ ✓

$(2x + 3)(x - 1) \geq 0$ ✓

Get into the standard form ($ax^2 + bx + c \leq 0$)

Divide both sides by -1 to change the coefficient of x^2 to a positive

Factorise the trinomial

Critical values:

$x = \frac{-3}{2}$ and $x = 1$

We now indicate $\frac{-3}{2}$ and 1 on a number line.

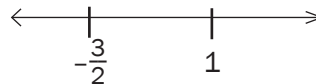

We know that the expression $2x^2 + x - 3 = 0$ at $x = \frac{-3}{2}$ and $x = 1$. We can indicate this on the number line.

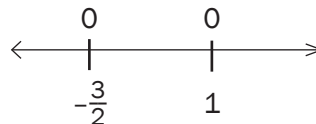

Our next step is to choose values less than $\frac{-3}{2}$, values between $\frac{-3}{2}$ and 1 and values greater than 1 and substitute it into the expression $2x^2 + x - 3$. If the answer is positive, then we indicate $+$ on the number line. If the answer is negative, we indicate $-$ on the number line

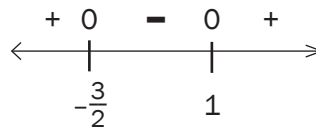

We have to solve for x where $2x^2 + x - 3 \geq 0$. The solution on the number line is the interval where we see zero and a positive. This happens for the x values less than or equal to $-\frac{3}{2}$ and for the x values greater than or equal to 1.

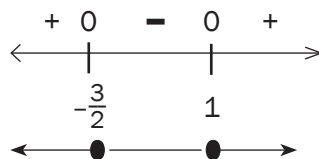

Therefore the solution is : $x \leq -\frac{3}{2}$ or $x \geq 1$ ✓✓ (5)

OR ALTERNATIVE METHOD by using a rough sketch of the parabola:

$$-x < 2x^2 - 3$$

Get into the standard form $ax^2 + bx + c < 0$

$$-2x^2 - x + 3 < 0$$

Divide both sides by -1 .

$$\frac{-2x}{-1} - \frac{x}{-1} + \frac{3}{-1} > 0$$

This is necessary to draw the rough sketch of a “positive” parabola

$$2x^2 + x - 3 > 0 \quad \checkmark$$

With 0 on RHS

$$(2x + 3)(x - 1) > 0 \quad \checkmark$$

Factorise LHS

Critical values of x : $-\frac{3}{2}$ and $= 1$

Make a rough sketch of a parabola

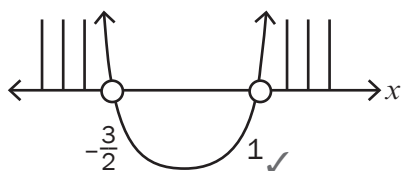

If $(***)(***) > 0$ (it means where y is positive)

Read off the x values of the graph above the x -axis

$$\therefore x < -\frac{3}{2} \text{ or } x > 1 \quad \checkmark\checkmark$$

(5)

[10]

2.8 Simultaneous equations

e.g. 19



When you divide, you sometimes need to round off to the closest numbers that are easier to divide.

Solve for x and y simultaneously:

$$y + 2x - 2 = 0 \quad \text{and} \quad 2x^2 + y^2 = 3yx$$

In this example, a quadratic equation and a linear equation must be solved simultaneously. Use the following steps:

Step 1: Use the linear equation to make one of the unknowns the subject of the equation (i.e. get x or y alone on one side of the equation).

Step 2: Substitute x or y (whichever is the subject of the equation) into the quadratic equation. The equation will contain only one unknown.

Step 3: Solve the one unknown.

Step 4: Substitute the solved unknown into the linear equation to solve for the other unknown.



Always label the equations: equation 1 (eqn 1) and equation 2 (eqn 2)

Solution

$$y + 2x - 2 = 0 \quad \dots\dots\dots \text{eqn (1)}$$

$$2x^2 + y^2 = 3yx \quad \dots\dots\dots \text{eqn (2)}$$

Step 1: $y + 2x - 2 = 0 \dots\dots\dots$ from eqn (1)
 $\therefore y = 2 - 2x \dots\dots\dots$ eqn (3)

Step 2: Substitute eqn (3) in eqn (2)
 $2x^2 + y^2 = 3yx$
 $\therefore 2x^2 + (2 - 2x)^2 = 3x(2 - 2x)$

Step 3: $2x^2 + (2 - 2x)(2 - 2x) = 3x(2 - 2x)$
 $2x^2 + 4 - 8x + 4x^2 = 6x - 6x^2$
 $12x^2 - 14x + 4 = 0$
 $\div 2 \therefore 6x^2 - 7x + 2 = 0$
 $\therefore (3x - 2)(2x - 1) = 0$
 $\therefore x = \frac{2}{3} \text{ or } x = \frac{1}{2}$

Step 4: Substitute $x = \frac{2}{3}$ in eqn (3) Substitute $x = \frac{1}{2}$ in eqn (3)
 $\therefore y = 2 - 2 \left(\frac{2}{3}\right) = \frac{2}{3}$ $\therefore y = 2 - 2 \left(\frac{1}{2}\right) = 1$



If the coefficient of y in the linear equation is one, get y alone on one side of the equation. If the coefficient of x in the linear equation is one, get x alone on one side of the equation. This way, you will not have to deal with fractions.

e.g. 20

Given the functions $y = \frac{6}{x}$ and $y = x - 1$, find the coordinates of the points of intersection of the two graphs algebraically.

$$y = \frac{6}{x} \quad \dots \quad \text{eqn (1)}$$

$$y = x - 1 \quad \dots \quad \text{eqn (2)}$$

Substitute eqn (2) into eqn (1):

(Wherever there is a y , replace it with $(x - 1)$, using brackets)

$$x - 1 = \frac{6}{x}$$

$$\therefore x^2 - x = 6 \quad \text{LCD} = x$$

$$\therefore x^2 - x - 6 = 0$$

$$\therefore (x - 3)(x + 2)$$

$$\therefore x = 3 \text{ and } x = -2$$

Subst. $x = 3$ in eqn(2):

$$y = 3 - 1 = 2$$

Subst. $x = -2$ in eqn(2):

$$y = -2 - 1 = -3$$

$\therefore (3; 2)$ and $(-2; -3)$ are the points of intersection

Both these points satisfy the equations.

The graphs of the two equations will intersect at two points.

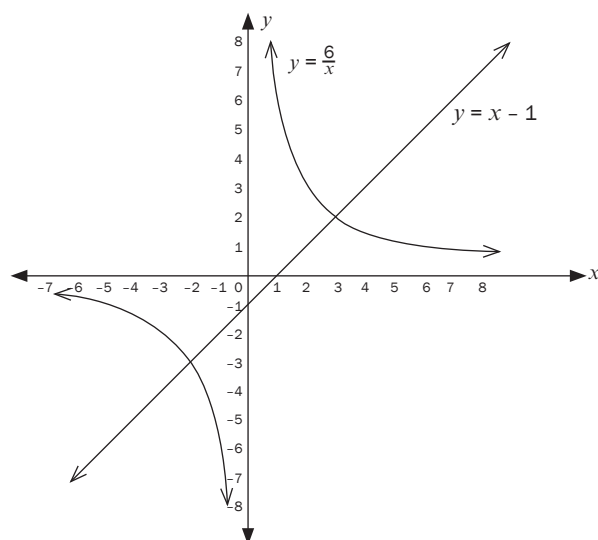

In order to determine the points of intersection of two graphs, we solve the equations of the graphs simultaneously.





Activity 6

Solve the following equations simultaneously.

- $2x + y = 3$ and $x^2 + y + x = y^2$
- $y = \frac{-6}{x+1} - 2$ and $y = -3x + 2$

[14]

Solutions

$$1. \quad 2x + y = 3 \quad \dots\dots\dots \text{eqn (1)}$$

$$x^2 + y + x = y^2 \quad \dots\dots\dots \text{eqn (2)}$$

$$y = -2x + 3 \quad \checkmark \quad \dots\dots\dots \text{eqn (3)}$$

Use the linear equation (1) to write y alone on one side of the equation.

Substitute eqn (3) into eqn (2), to eliminate the y variable.

$$x^2 + (-2x + 3) + x = (-2x + 3)^2 \quad \checkmark$$

Simplify both sides.

$$x^2 - x + 3 = 4x^2 - 12x + 9$$

Factorise the trinomial.

$$0 = 3x^2 - 11x + 6 \quad \checkmark$$

$$0 = (3x - 2)(x - 3) \quad \checkmark$$

$$\therefore 3x - 2 = 0 \quad \text{or} \quad x - 3 = 0$$

$$\therefore x = \frac{2}{3} \quad \text{or} \quad \therefore x = 3 \quad \checkmark$$

Substitute these two values of x into eqn (3) to find the values for y :

$$\text{Subst } x = \frac{2}{3} \text{ in eqn (3)}$$

$$\text{Subst } x = 3 \text{ in eqn (3)}$$

$$\therefore y = -2\left(\frac{2}{3}\right) + 3 = \frac{5}{3} \quad \checkmark$$

$$\therefore y = -2(3) + 3 = -3 \quad \checkmark \quad (7)$$

So there are two solutions: $\left(\frac{2}{3}, \frac{5}{3}\right)$ and $(3; -3)$

$$2. \quad y = \frac{-6}{x+1} - 2 \quad \text{and} \quad y = -3x + 2$$

$$y = \frac{-6}{x+1} - 2 \quad \dots\dots\dots (\text{eqn 1})$$

$$y = -3x + 2 \quad \dots\dots\dots (\text{eqn 2})$$

y is alone on one side of both equations.

$$\therefore y = \frac{-6}{x+1} - 2 = -3x + 2 \quad \checkmark \quad \dots\dots\dots \text{LCD} = x + 1$$

$$\therefore -6 - 2(x + 1) = -3x(x + 1) + 2(x + 1) \quad \checkmark$$

$$\therefore -6 - 2x - 2 = -3x^2 - 3x + 2x + 2$$

$$\therefore 3x^2 - x - 10 = 0 \quad \checkmark$$

$$\therefore (3x + 5)(x - 2) = 0 \quad \checkmark$$

$$\therefore x = -\frac{5}{3} \quad \text{or} \quad x = 2 \quad \checkmark$$

$$\text{Subst } x = -\frac{5}{3} \text{ in eqn (2)}$$

$$\text{Subst } x = 2 \text{ in eqn (2)}$$

$$y = -3\left(-\frac{5}{3}\right) + 2 = 7 \quad \checkmark$$

$$y = -3(2) + 2 = -4 \quad \checkmark \quad (7)$$

[14]

2.9 The nature of the roots

2.9.1 Determine the nature of the roots

The roots of any quadratic equation $ax^2 + bx + c = 0$ can be found by

$$x = \frac{-b \pm \sqrt{b^2 - 4ac}}{2a}$$

- The roots of a quadratic equation are the x -values when the equation is zero.
- The roots are the x -intercepts of the graph.
- When you are asked to 'determine the nature of the roots of an equation', you are NOT asked to solve the equation.

Summary:

To find the nature of the roots of a quadratic equation $ax^2 + bx + c = 0$, look at the value of D , the discriminant.

- If $\Delta < 0$: The roots are non-real/no real roots.
- If $\Delta = 0$: There are two equal, real and rational roots.
- If $\Delta > 0$: There are two real roots which may be rational or irrational.
 - If D is a perfect square, the roots are rational.
 - If D is not a perfect square, then the roots are irrational

The nature of the roots also tells us about the x -intercepts of the graph of the quadratic equation.



Nature of roots

Graphs

$$\Delta < 0$$

Roots are non-real.

There are no x -intercepts.

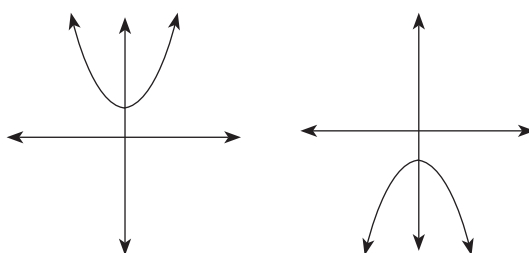

$$\Delta = 0$$

Roots are real and equal.

There is only one x -intercept and it is at the turning point of the graph.

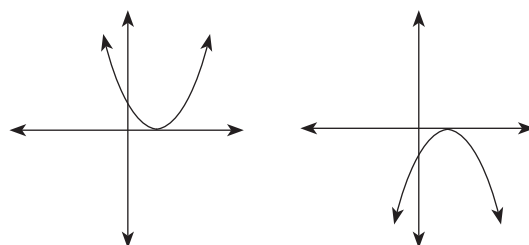

$$\Delta > 0$$

Roots are real and unequal (two roots):

If Δ is a squared rational number, roots are rational.

If Δ is not a squared number, the roots are irrational.

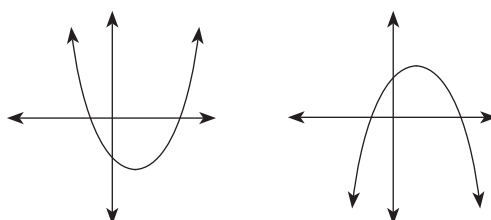

 **21**

1. $x = \frac{-6 \pm \sqrt{25}}{4}$

$\Delta = 25 \therefore \Delta > 0$, so there are two real roots.

We can see that 25 is a perfect square ($\sqrt{25} = 5$)

So the roots will be **real, rational** and **unequal**.

2. $x = \frac{4 \pm \sqrt{24}}{2}$

$\Delta = 24 \therefore \Delta > 0$, so there are two real roots. 24 is not a perfect square ($\sqrt{24} = 4,898979486\dots$)

So the roots will be **real, irrational** and **unequal**.

3. $x = \frac{-5 \pm \sqrt{-9}}{8}$

$\Delta = -9 \therefore \Delta < 0$, so $\sqrt{-9}$ is non-real. There are no real solutions for x , so the roots are **non-real**.

 **22**

The solutions to a quadratic equation are: $x = 5 \pm \sqrt{10 + 2a}$.

For which values of a will the equation have equal roots.

Solution

The equation will have equal roots if $\Delta = 0$.

$$\Delta = 10 + 2a$$

$$0 = 10 + 2a$$

$$10 = -2a$$

$$\therefore a = -5$$

Activity 7

- Show that the roots of $x^2 - 2x - 7 = 0$, are irrational, without solving the equation. (3)
- Show that $x^2 + x + 1 = 0$ has no real roots. (3)
- If $x = 2$ is a root of the equation $3x^2 - 5x - 2k = 0$, determine the value of k . (2)
- The solutions to a quadratic equation are: $x = 5 \pm \sqrt{12 - 3a}$.
For which value(s) of a will the equation have equal roots. (3)
- Determine the value(s) of k for which the equation $3x^2 + (k + 2)x + k = 0$ has equal roots (4)

[15]

Solutions

1. $a = 1; b = -2; c = -7$

$$\begin{aligned}\Delta &= b^2 - 4ac = (-2)^2 - 4(1)(-7) \quad \checkmark \\ &= 4 + 28 \\ &= 32 \quad \checkmark\end{aligned}$$

 \therefore The roots will be irrational \checkmark $(\Delta > 0$ and not a perfect square)

(3)

2. $a = 1; b = 1; c = 1$

$$\begin{aligned}\Delta &= b^2 - 4ac = (1)^2 - 4(1)(1) \quad \checkmark \\ &= 1 - 4 = -3 \quad \checkmark\end{aligned}$$

 \therefore There are no real roots $(\Delta < 0) \quad \checkmark$

(3)

3. If 2 is a root of the equation, then $x = 2$. Therefore, we can substitute $x = 2$ into the equation.

$3x^2 - 5x - 2k = 0$

$\therefore 3(2)^2 - 5(2) - 2k = 0 \quad \checkmark$

$\therefore 12 - 10 - 2k = 0$

$\therefore 2k = 2$

$\therefore k = 1 \quad \checkmark$

(2)

4. The equation will have equal roots if $\Delta = 0$

$\Delta = 12 - 3a$

$0 \quad \checkmark = 12 - 3a \quad \checkmark$

$-12 = -3a$

$\therefore a = 4 \quad \checkmark$

(3)

5. $3x^2 + (k + 2)x + k = 0$

$\therefore a = 3; b = (k + 2); c = k$

$\therefore \Delta = b^2 - 4ac$

$= (k + 2)^2 - 4(3)(k) \quad \checkmark$

$= k^2 + 4k + 4 - 12k$

$= k^2 - 8k + 4 \quad \checkmark$

For equal roots the $\Delta = 0 \quad \checkmark$

$\therefore k^2 - 8k + 4 = 0$

$\therefore k = \frac{8 \pm \sqrt{(-8)^2 - 4(1)(4)}}{2(1)}$

$\therefore k = \frac{8 \pm \sqrt{48}}{2}$

$\therefore k = 7,46$ or $k = -0,54 \quad \checkmark$

(4)

[15]

32 is not a perfect square so the roots are irrational.

 $-3 < 0$ \therefore is non-real

2.9.2 Problem solving using quadratic equations

You can use an equation to represent a problem. Find what part of the problem is unknown and needs to be represented by a variable.

hint

m^2 here means square metres. It is not a variable.

hint

Dimensions: the measurements of the sides

e.g. 23

The area of a rectangle is 12 m^2 .

The length is 4 metres longer than the breadth. Find the dimensions of the rectangle.

We don't know the length or the breadth of the rectangle.

We do know that the length is 4 m longer than the breadth.

It makes sense to let the breadth be x metres. Then the length is $x + 4$ metres.

Draw a picture to help you. Let breadth be x metres

Area of rectangle = length \times breadth

$$12 = (x + 4)x$$

$$12 = x^2 + 4x$$

$$0 = x^2 + 4x - 12$$

$$0 = (x + 6)(x - 2)$$

$$\therefore x + 6 = 0 \quad \text{or} \quad x - 2 = 0$$

$$x = -6$$

$$x = 2$$

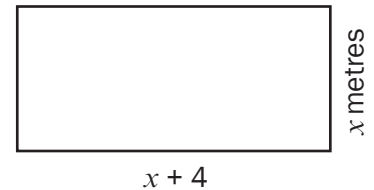

Length and breadth must both be positive lengths. You can't have a negative length!

So $x \neq -6$

$\therefore x = 2$ and so the breadth is 2 metres.

The length is $x + 4$ and so the length is 6 metres.

What you need to be able to do:

- Solve quadratic equations by factorising when possible.
- Rewrite a quadratic equation that is written in the general form $y = ax^2 + bx + c$ in the form $y = a(x + p)^2 + q$ by completing the square.
- Use completing the square to solve quadratic equations.
- Use the formula $x = \frac{-b \pm \sqrt{b^2 - 4ac}}{2a}$ to determine the roots of an equation.
- Use the value of the discriminant ($b^2 - 4ac$) of a quadratic equation to determine the nature of the roots.
- Solve linear and quadratic inequalities.
- Solve simultaneous equations to find the points of intersection between two different functions.



Feb/March 2014 Q1.1.1 & Q1.1.2 & Q1.2 & Q1.3

Nov 2013 Q1.1.1 & Q1.1.2a,b & Q1.1.3 & Q1.2

Feb/March 2013 Q1.1.1 & Q1.1.2 & Q1.1.4 & Q1.2.1 & Q1.2.2 & Q1.2.3

Nov 2012 Q1.1.1 & Q1.1.1 & Q1.1.3 & Q1.2.1 & Q1.3.1 & Q1.3.2

Feb/March 2012 1.1.1 & 1.1.2 & 1.1.3 & 1.2

Nov 2011 Q1.1.1 & Q1.1.2 & Q1.1.3 & Q1.2

Feb/March 2011 Q1.1.1 & Q1.1.2 & Q1.1.3 & Q1.2



Keep going!

3

Unit

Number patterns, sequences and series

3.1 Number patterns

A list of numbers in order is called a number pattern or number sequence.

We need at least three numbers in the list to work out if the numbers form a pattern. If we only have two numbers, we cannot be sure what the pattern is.

For example, if we have the list 2; 4; ... many different number patterns are possible:

- The pattern could be 2; 4; 6; ... add 2 to each number to get the next number
 OR 2; 4; 8; ... multiply each number by 2 to get the next number
 OR 2; 4; 2; 4; ... repeat the pattern

A single number in a pattern or sequence is called a **term**.

Term 1 is written as T_1 , term 2 is written as T_2 and so on. The number of the term shows its position in the sequence.

T_{10} is the 10th term in the sequence.

T_n is the n th term in a sequence.



1. Look at the number pattern 3; 8; 13; ...

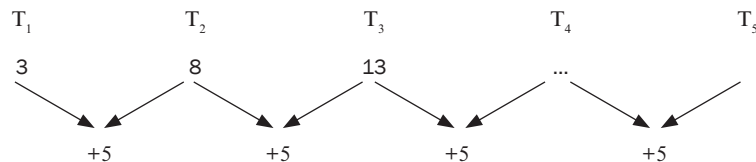

If we keep adding 5 to each term we get the next term:

$$T_4 = 13 + 5 = 18; \quad T_5 = 23; \quad T_6 = 28, \text{ etc.}$$

2. Look at the number pattern 5; 15; 45; ...

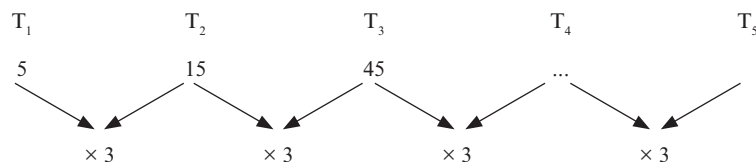

In this pattern, each term is multiplied by 3 to get the next term.

So $T_4 = 45 \times 3 = 135$; $T_5 = 405$; $T_6 = 1\,215$, and so on.

3. Look at the sequence: 1; 4; 9; ...

$$T_1 = 1^2; T_2 = 2^2; T_3 = 3^2$$

These are all perfect square numbers. Each number is the number of the term squared.

So $T_4 = (4)^2 = 16$; $T_5 = (5)^2 = 25$; $T_6 = (6)^2 = 36$, and so on.

It is important to learn to recognise square numbers.

3.2 Arithmetic sequences

Arithmetic sequence is a sequence where the common difference (d) between consecutive terms is constant.

$$T_2 - T_1 = T_3 - T_2 = T_n - T_{n-1} = d \text{ (common difference)}$$

- e.g. 2** Given the sequence: 5; 9; 13; 17; . . .
- Determine the common difference
 - Determine the next two terms

Solution

$$d = 9 - 5 = 13 - 9 = 4$$

$$T_5 = 17 + 4 = 21 \text{ and } T_6 = 21 + 4 = 25$$

If we use a for the first term T_1 , d for the common difference, then the general term T_n for an arithmetic sequence is: $T_n = a + (n - 1)d$

- e.g. 3** Given the sequence 4; 10; 16; . . .
- Determine a formula for the n th term of the sequence.
 - Calculate the 50th term.
 - Which term of the sequence is equal to 310

Solutions

a) $a = 4$ and $d = 10 - 4 = 16 - 10 = 6$

$$\begin{aligned} T_n &= a + (n - 1)d \\ &= 4 + (n - 1)6 \\ &= 4 + 6n - 6 \\ &= 6n - 2 \end{aligned}$$

b) $T_{50} = 6 \times 50 - 2$

$$\begin{aligned} &= 300 - 2 \\ &= 298 \end{aligned}$$

c) $6n - 2 = 310$

$$\begin{aligned} 6n &= 312 \\ n &= 52 \end{aligned}$$

or by looking at the structure, the numbers are 2 less than the multiples of 6
i.e. $T_n = 6n - 2$





Activity 1

- Given the sequence 6; 13; 20; ...
 - Determine a formula for the n th term of the sequence.
 - Calculate the 21st term of this sequence.
 - Determine which term of this sequence is 97. (5)
- Consider this number pattern: 8; 5; 2; ...
 - Calculate the 15th term.
 - Determine which term of this sequence is -289 . (4)
- Given the arithmetic sequence $1 - p; 2p - 3; p + 5; \dots$ determine the value of p .
 - Determine the values of the first three terms of the sequence. (5)

[14]

Solutions

- It is an arithmetic sequence because there is a common difference.
 $a = 6; d = 7 \quad T_n = a + (n - 1)d \checkmark$
 $T_n = 6 + (n - 1)(7)$
 $T_n = 7n - 1 \checkmark$
 - $T_{21} = 7(21) - 1 = 147 - 1 = 146 \checkmark$
 - $97 = 7n - 1 \checkmark$
 $\therefore 98 = 7n$
 $\therefore 14 = n \checkmark$
 $\therefore 97$ is the 14th term of the sequence. (5)
- It is an arithmetic sequence: $a = 8; d = 5 - 8 = 2 - 5 = -3$
 $T_n = a + (n - 1)d$
 $\therefore T_{15} = 8 + (15 - 1)(-3) \checkmark$
 $T_{15} = 8 + 14(-3)$
 $T_{15} = 8 - 42 = -34 \checkmark$
 - $T_n = a + (n - 1)d$
 $-289 = 8 + (n - 1)(-3) \checkmark$
 $\therefore -289 = 8 - 3n + 3$
 $\therefore -300 = -3n$
 $\therefore 100 = n \quad \checkmark \quad \therefore -289$ will be the 100th term (4)
- Since this is an arithmetic sequence, you can assume that there is a common difference between the terms.
 $d = T_2 - T_1 = T_3 - T_2$
 $\therefore (2p - 3) - (1 - p) = (p + 5) - (2p - 3) \checkmark$
 $3p - 4 = -p + 8 \checkmark$
 $4p = 12$
 $p = 3 \checkmark$
 - $p = 3$
 $T_1 = 1 - p = 1 - 3 = -2$
 $T_2 = 2p - 3 = 2(3) - 3 = 3 \checkmark$
 $T_3 = p + 5 = 3 + 5 = 8 \checkmark$
 So the first three terms of the sequence are $-2; 3; 8$ (5)

[14]

3.3 Quadratic sequences

At least four numbers are needed to determine whether the sequence is quadratic or not.

Consider this number pattern:

There is no common difference between the numbers.

The differences are
6; 10; 14; 18.

Now we can see if there is a second common difference.

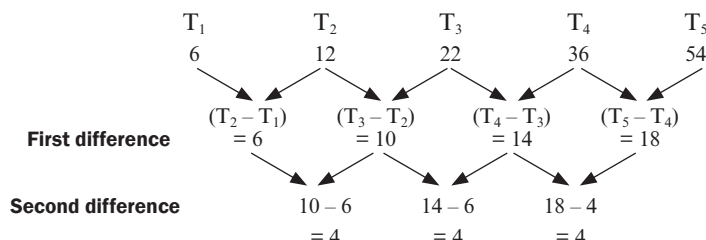

In this sequence, there is a second common difference of 4.

The next term will be: $T_6 = 54 + (18 + 4) = 76$

A pattern with a common second difference is called a **quadratic number sequence**.

The general formula for any term of a quadratic sequence is: $T_n = an^2 + bn + c$

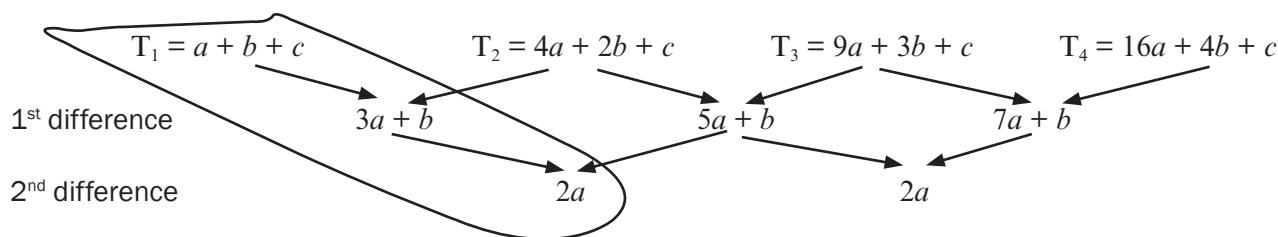

If $T_n = an^2 + bn + c$
 then $2a$ is the second difference
 $3a + b$ is $T_2 - T_1$
 $a + b + c$ is the first term

e.g. 4 Look at the number sequence 12; 20; 32; 48; ...

2nd common difference is 4

So $2a = 4$ $\therefore a = 2$

2. $T_2 - T_1 = 8$
 So $3a + b = 8$ $\therefore 3(2) + b = 8$
 $\therefore b = 2$

3. 1st term is 12
 So $a + b + c = 12$ $\therefore 2 + 2 + c = 12$
 $\therefore c = 8$

$\therefore T_n = 2n^2 + 2n + 8$

$\therefore T_5 = 2(5)^2 + 2(5) + 8 = 68$

$\therefore T_6 = 2(6)^2 + 2(6) + 8 = 92$

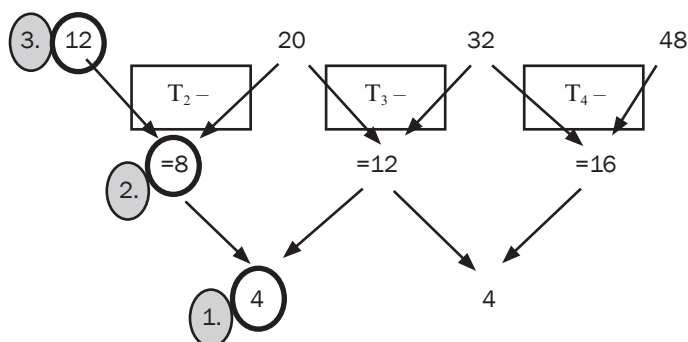



Activity 2

- Consider the number pattern: 3; 13; 31; 57; 91; ...
 - Determine the general term for this pattern.
 - Calculate the 7th term of this pattern.
 - Which term is equal to 241? (9)
- Find term 6 of this pattern and then find the rule in the form $T_n = an^2 + bn + c$
 -1 ; 3; 9; 17; 27 ... (4)

[13]

Solutions

1. a) It helps to make a diagram:

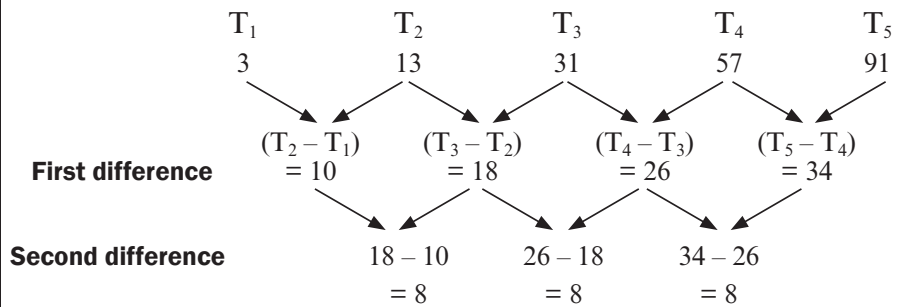

\therefore it is a quadratic sequence.

$$2a = 8 \therefore a = 4 \quad \checkmark$$

$$3a + b = 10 \therefore 3(4) + b = 10$$

$$b = -2 \quad \checkmark$$

$$a + b + c = 3 \therefore 4 + (-2) + c = 3$$

$$c = 1 \quad \checkmark$$

$$\therefore T_n = 4n^2 - 2n + 1 \quad \checkmark$$

b) $T_7 = 4(7)^2 - 2(7) + 1 \quad \checkmark$

$$= 4(49) - 14 + 1$$

$$= 183 \quad \checkmark$$

c) $241 = 4n^2 - 2n + 1$

$$0 = 4n^2 - 2n + 1 - 241 \quad \checkmark \quad \text{make the equation} = 0 \text{ to solve}$$

$$0 = 4n^2 - 2n - 240$$

$$0 = 2n^2 - n - 120 \quad \text{divide through by 2}$$

$$0 = (2n + 15)(n - 8) \quad \checkmark$$

factorise

$$\therefore 2n + 15 = 0 \quad \text{OR} \quad n - 8 = 0$$

$$\therefore n = -7,5 \quad \text{OR} \quad n = 8 \quad \checkmark$$

(9)

n = -7,5 not possible because n is the position of the term so it must be a positive natural number. ✓

$\therefore 241$ is the 8th term of the sequence.



2.	T_1	T_2	T_3	T_4	T_5	
	-1	3	9	17	27	...
	4	6	8	10		
	2	2	2			✓

$\therefore T_6 = 27 + (10 + 2) = 39$ ✓ use the pattern of the numbers
 $2a = 2 \therefore a = 1$
 $3a + b = 4$
 $3(1) + b = 4 \therefore b = 1$
 $a + b + c = -1$
 $1 + 1 + c = -1 \therefore c = -3$
 $T_n = n^2 + n - 3$ ✓✓

(4)
[13]

3.4 Geometric sequences

When there is a **common ratio** (r) between consecutive terms, we can say this is a **geometric sequence**.

If the first term (T_1) is a , the common ratio is r , and the general term is T_n , then:

$$r = \frac{T_2}{T_1} = \frac{T_3}{T_2} = \frac{T_n}{T_{n-1}} \text{ and}$$

$$T_n = ar^{n-1}$$

Given the sequence, check whether it is arithmetic, geometric or quadratic.

Look at the sequence 5; 15; 45; 135; 405; ...

$$\frac{15}{5} = 3 \quad \frac{45}{15} = 3 \quad \text{and} \quad \frac{135}{45} = 3 \quad \text{and so the common ratio is 3.}$$

Therefore the sequence is geometric. To get the next term you multiply the preceding term by the common ratio.

e.g. 5

Given the sequence $1; \frac{2}{3}; \frac{4}{9}; \dots$

a) Determine the next two terms

b) Which term of the sequence is equal to $\frac{32}{243}$?

Solutions

The common ratio is $\frac{2}{3}$ because $\frac{2}{3} \div 1 = \frac{2}{3} = \frac{4}{9} \div \frac{2}{3}$

a) $T_4 = ar^3 = 1\left(\frac{2}{3}\right)^3 = \frac{8}{27}$ and $T_5 = 1\left(\frac{2}{3}\right)^4 = \frac{16}{81}$

b) $a = 1; r = \frac{2}{3}$ and $T_n = ar^{n-1} = \frac{32}{243}$

$$\therefore T_n = (1)\left(\frac{2}{3}\right)^{n-1} = \frac{2^5}{3^5} = \left(\frac{2}{3}\right)^5$$

$$\therefore \left(\frac{2}{3}\right)^{n-1} = \left(\frac{2}{3}\right)^5$$

$$\therefore n - 1 = 5$$

$$n = 6$$

e.g. 6

In a geometric sequence, the fifth term is 80 and the common ratio is -2 . Determine the first three terms of the sequence.

$$T_5 = 80 \text{ and } r = -2$$

$$T_5 = ar^4 = a(-2)^4 = 80$$

$$16a = 80$$

$$a = 5$$

$$\therefore T_1 = 5; T_2 = 5(-2)^1 = -10; T_3 = 5(-2)^2 = 20$$

OR

$$T_4 = T_3 \times r =$$

$$\frac{4}{9} \times \frac{2}{3} = \frac{8}{27}$$

$$T_5 = T_4 \times r =$$

$$\frac{8}{27} \times \frac{2}{3} = \frac{16}{81}$$





Activity 3

- a) Determine the 10th term of the sequence: 3; 6; 12; . . . (2)
- b) Determine the number of terms in the sequence: 2; 4; 8; . . . ; 1024 (2)
- c) If 5; x ; 45 are the first three terms of a geometric sequence, determine the value of x . (2)
- d) Determine the geometric sequence whose 8th term is 9 and whose 10th term is 25. (3)

[9]

Solutions

a) $a = 3; r = \frac{6}{3} = \frac{12}{6} = 2$

$$T_n = ar^{n-1}$$

$$T_{10} = 3(2)^{10-1} = 3(2)^9 = 3 \times 512 = 1536 \checkmark\checkmark \quad (2)$$

b) $a = 2; r = \frac{4}{2} = \frac{8}{4} = 2$

$$ar^{n-1} = 1024$$

$$2(2)^{n-1} = 2^{10} = 2^n = 2^{10} \checkmark$$

$$\therefore n = 10 \quad \checkmark \quad (2)$$

c) $\frac{x}{5} = \frac{45}{x} \checkmark$

$$x = \pm \sqrt{225} = \pm 15 \checkmark \quad (2)$$

d) $ar^7 = 9$

$$ar^9 = 25$$

$$\frac{ar^9}{ar^7} = \frac{25}{9}$$

$$\therefore r^2 = \frac{25}{9}$$

$$r = \frac{5}{3} \checkmark$$

$$a = \frac{9}{\left(\frac{5}{3}\right)^7} = 9 \times \left(\frac{3}{5}\right)^7 \checkmark$$

The sequence is: $9\left(\frac{3}{5}\right)^7; 9\left(\frac{3}{5}\right)^6; 9\left(\frac{3}{5}\right)^5; 9\left(\frac{3}{5}\right)^4; 9\left(\frac{3}{5}\right)^3 \checkmark \quad (3)$

[9]

3.5 Arithmetic and geometric series

The proof must be learnt for exams



Add first terms:
 $a + [a + (n - 1)d]$
 $= 2a + (n - 1)d$

Add second terms:
 $a + d + [a + (n - 2)d]$
 $= 2a + (n - 1)d$

Add third terms:
 $a + 2d + [a + (n - 3)d]$
 $= 2a + (n - 1)d$

Add last terms:
 $[a + (n - 1)d] + a$
 $= 2a + (n - 1)d$

i.e. $(a + l)$, n times



When we add the terms of a sequence together, we form a series.
 We use the symbol S_n to show the sum of the first n terms of a series.

$$\text{So } S_n = T_1 + T_2 + T_3 + T_4 + \dots + T_n$$

3.5.1 Arithmetic series

The formula is $S_n = \frac{n}{2} [2a + (n - 1)d]$ where S_n is the sum of n terms,
 a is the first term,
 n is the number of terms and
 d is the common difference.

Proof

The general term of an arithmetic series is $T_n = a + (n - 1)d$

So $S_n = T_1 + T_2 + T_3 + T_4 + \dots + T_n$

$$S_n = a + [a + d] + a + 2d + \dots + [a + (n - 2)d] + [a + (n - 1)d] \dots \text{equation 1}$$

If we write the series in reverse we get:

$$S_n = [a + (n - 1)d] + [a + (n - 2)d] + [a + (n - 3)d] + \dots + [a + d] + a \dots \text{equation 2}$$

We can add equation 1 and equation 2.

$$\text{So } 2S_n = [2a + (n - 1)d] + [2a + (n - 1)d] + [2a + (n - 1)d] + \dots + [2a + (n - 1)d] + [2a + (n - 1)d]$$

$$2S_n = n [2a + (n - 1)d]$$

$$S_n = \frac{n}{2} [2a + (n - 1)d]$$

This formula is provided on the **information sheet** in the final exam.

Alternative Proof

Or $S_n = a + [a + d] + [a + 2d] + \dots + [l - d] + l \dots \text{equation 1}$

In reverse $S_n = [a + (n - 1)d] + [a + (n - 2)d] + [a + (n - 3)d] + \dots + [a + d] + a$

$$S_n = l + [l - d] + [l - 2d] + \dots + [a + d] + a \dots \text{equation 2}$$

Adding equation 1 and equation 2

$$2S_n = [a + l] + [a + l] + \dots + [a + l] \quad n \text{ times}$$

$$2S_n = n[a + l]$$

$$\therefore S_n = \frac{n}{2} [a + l]$$

e.g. 7

- Determine the sum of the first 20 terms of the series:
 $3 + 7 + 11 + 15 + \dots$
- The sum of the series $5 + 3 + 1 + \dots$ is -216 , determine the number of terms in the series

Solutions

1. $a = 3, n = 20, d = 4$

$$S_n = \frac{n}{2} [2a + (n - 1)d]$$

$$S_{20} = \frac{20}{2} [2(3) + (19)4]$$

$$S_{20} = 10(6 + 76)$$

$$S_{20} = 820$$

The sum of the first 20 terms is 820

2. $a = 5 \quad d = -2 \quad S_n = -216 \quad S_n = \frac{n}{2} [2a + (n - 1)d] \quad n = ?$

Substitute into the formula:

$$-216 = \frac{n}{2} [2(5) + (n - 1)(-2)]$$

$$-216 = \frac{n}{2} [10 + -2n + 2]$$

$$-216 = \frac{n}{2} [12 - 2n]$$

$$-432 = 12n - 2n^2$$

$$-432 = -2n^2 + 12n \quad \dots \text{ Make equation } = 0$$

$$2n^2 - 12n - 432 = 0 \quad \dots \text{ Divide through by 2 (common factor)}$$

$$n^2 - 6n - 216 = 0 \quad \dots \text{ Factorise trinomial}$$

$$(n - 18)(n + 12) = 0$$

$$\therefore n - 18 = 0 \text{ or } n + 12 = 0$$

$$n = 18 \quad \text{or} \quad n = -12$$

$$n > 0 \quad \therefore n = 18$$

\therefore 18 terms of the series add up to -216 .

**Activity 4**

- Determine the sum of the series: $19 + 22 + 25 + \dots + 121$ (3)
- The sum of the series $22 + 28 + 34 + \dots$ is 1870. Determine the number of terms. (2)
- Given the arithmetic sequence $-3; 1; 5; \dots, 393$
 - Determine a formula for the n th term of the sequence.
 - Write down the 4th, 5th, 6th and 7th terms of the sequence.
 - Write down the remainders when each of the first seven terms of the sequence is divided by 3.
 - Calculate the sum of the terms in the arithmetic sequence that are divisible by 3. (10)
- The sum of n terms is given by $S_n = \frac{n}{2} (1 + n)$. Determine T_5 . (3)
- $3x + 1; 2x; 3x - 7$ are the first three terms of an arithmetic sequence. Calculate the value of x . (3)
- The first and second terms of an arithmetic sequence are 10 and 6 respectively.
 - Calculate the 11th term of the sequence.
 - The sum of the first n terms of this sequence is -560 . Calculate n . (6)

[27]

Solutions

1. $a = 19$ and $d = 3$

$$T_n = 3n + 16 = 121$$

$$3n = 105$$

$$n = 35 \quad \checkmark$$

$$S_n = \frac{n}{2}(a + 1)$$

$$S_{35} = \frac{35}{2}(19 + 121) = \frac{35}{2}(140) = 35 \times 70 = 2450 \quad \checkmark \quad (3)$$

2. $a = 22$ and $d = 6$

$$S_n = \frac{n}{2}[2a + (n - 1)d]$$

$$\frac{n}{2}[2 \times 22 + (n - 1)6] = 1870 \quad \checkmark$$

$$19n + 3n^2 = 1870$$

$$3n^2 + 19n - 1870 = 0$$

$$(3n + 85)(n - 22) = 0 \quad \checkmark$$

$$\therefore n = 22$$

n cannot be a negative because it is the number of terms (2)

3. a) $T_n = -3 + (n - 1)4 \quad \checkmark$

$$4n - 7 = T_n \quad \checkmark$$

b) $T_4 = 5 + 4 = 9; \quad T_5 = 9 + 4 = 13; \quad \checkmark \quad T_6 = 13 + 4 = 17 \quad \text{and}$

$$T_7 = 17 + 4 = 21 \quad \checkmark$$

c) $0; 1; 2; 0; 1; 2; 0 \quad \checkmark \checkmark$

d) $T_n = -3 + 12(n - 1) \quad \checkmark$

$$393 = 12n - 15$$

$$12n = 393 + 15 = 408 \quad \checkmark$$

$$n = 34$$

$$S_{34} = \frac{34}{2} \times (-3 + 393)$$

$$= 17 \times 390 \quad \checkmark \checkmark$$

$$= 6630 \quad (10)$$

4. $S_5 = \frac{5}{2}(1 + 5) = 15 \quad \checkmark$

$$S_4 = \frac{4}{2}(1 + 4) = 10 \quad \checkmark$$

$$T_5 = 15 - 10 = 5 \quad \checkmark \quad (3)$$

5. $T_2 - T_1 = T_3 - T_2$

$$2x - (3x + 1) = (3x - 7) - 2x \quad \checkmark$$

$$2x - 3x - 1 = 3x - 7 - 2x$$

$$-2x + 6 = 0 \quad \checkmark$$

$$2x = 6$$

$$x = 3 \quad \checkmark \quad (3)$$

6. a) $T_n = a + (n - 1)d$

$$T_{11} = 10 + (11 - 1)(-4) \quad \checkmark$$

$$= -30 \quad \checkmark$$

b) $S_n = \frac{n}{2} [2a + (n - 1)d]$

$$-560 = \frac{n}{2} [2(10) + (n - 1)(-4)] \quad \checkmark$$

$$-1120 = -4n^2 + 24n$$

$$4n^2 - 24n - 1120 = 0$$

$$n^2 - 6n - 280 = 0 \quad \checkmark$$

$$(n - 20)(n + 14) = 0 \quad \checkmark$$

$$n = 20 \text{ or } n = -14$$

$$n = 20 \text{ only } \checkmark \text{ because number of terms cannot be a negative number} \quad (6)$$

[27]

3.5.2 Geometric series

The formula is

$$S_n = \frac{a(r^n - 1)}{r - 1} \text{ for } r > 1 \text{ or } S_n = \frac{a(1 - r^n)}{1 - r} \text{ for } r < 1$$

where a is the first term

r is the common ratio

n is the number of terms

S_n is the sum of the terms

Proof:

The general term of a geometric series is $T_n = ar^{n-1}$

$$\text{So } S_n = T_1 + T_2 + T_3 + T_4 + \dots + T_n$$

$$S_n = a + ar + ar^2 + \dots + ar^{n-2} + ar^{n-1}$$

$$rS_n = ar + ar^2 + ar^3 + \dots + ar^{n-1} + ar^n$$

multiply each term by r

$$\frac{S_n = a + ar + ar^2 + \dots + ar^{n-2} + ar^{n-1}}{rS_n - S_n = -a + 0 + 0 + \dots + 0 + 0 + ar^n}$$

write down the series again with like terms under each other

$$\therefore rS_n - S_n = ar^n - a$$

subtract each bottom term from each top term

$$S_n(r - 1) = a(r^n - 1)$$

S_n and a are common factors

$$\text{So } S_n = \frac{a(r^n - 1)}{r - 1}$$

Divide through by $(r - 1)$

$$\text{We can also use for } S_n = \frac{a(1 - r^n)}{1 - r} \text{ for } r < 1$$

The proof must be learnt for exams



 **8**

Evaluate: $25 + 50 + 100 + \dots$ to 6 terms

Solution

We need to check if this is an arithmetic series or a geometric series first.

You should see that there is a common ratio of 2 because $\frac{50}{25} = 2$ and $\frac{100}{50} = 2$

$$r = 2$$

\therefore It is a geometric series and $a = 25$, $n = 6$, $r = 2$

$$S_n = \frac{a(1 - r^n)}{1 - r}$$

$$S_6 = \frac{25(1 - 2^6)}{1 - 2} \quad 2^6 = 64$$

$$S_6 = \frac{25(1 - 64)}{-1}$$

$$S_6 = \frac{25(-63)}{-1}$$

$$= 1\,575$$

So the sum of the first 6 terms of the series is 1 575.

**Activity 5**

- Determine $3 + 6 + 12 + 24 + \dots$ to 10 terms (2)
- If $2 + 6 + 18 + \dots = 728$, determine the value of n . (3)

[5]

Solutions

$$1. \quad a = 3 \text{ and } r = \frac{6}{3} = \frac{12}{6} = 2$$

$$S_n = \frac{a(r^n - 1)}{r - 1}$$

$$S_{10} = \frac{3(2^{10} - 1)}{2 - 1} = 3(1024 - 1) = 3069 \quad \checkmark \quad (2)$$

$$2. \quad a = 2 \text{ and } r = \frac{6}{2} = \frac{18}{6} = 3$$

$$S_n = \frac{2(3^n - 1)}{3 - 1} = 728 \quad \checkmark$$

$$\frac{2(3^n - 1)}{2} = 728$$

$$3^n - 1 = 728$$

$$3^n = 729 = 3^6 \quad \checkmark$$

$$\therefore n = 6 \quad \checkmark$$

(3)

[5]

3.5.3 Sigma notation

Here is another useful way of **representing** a series.
The sum of a series can be written in **sigma notation**.
The symbol sigma is a Greek letter that stands for ‘the sum of’.

Σ is the symbol for ‘the sum of’

$\sum_{k=1}^n T_k$ means ‘the sum of the terms T_k from $k = 1$ to $k = n$.’

In other words, $\sum_{k=1}^n T_k = T_1 + T_2 + T_3 + T_4 + \dots + T_n$

e.g. 9

$$\sum_{k=3}^{17} p^k = p^3 + p^4 + p^5 + \dots + p^{17}$$



Activity 6

- Evaluate: $\sum_{n=4}^{70} (2n - 4)$ (3)
- What is the value of m for which $\sum_{k=1}^m 5(3)^{k-1} = 65$? (4)
- Consider the sequence: $\frac{1}{2}; 4; \frac{1}{4}; 7; \frac{1}{8}; 10; \dots$
 - If the pattern continues in the same way, write down the next TWO terms in the sequence.
 - Calculate the sum of the first 50 terms of the sequence. (5)

[12]



hint

Look for two different sequences in the pattern and separate them

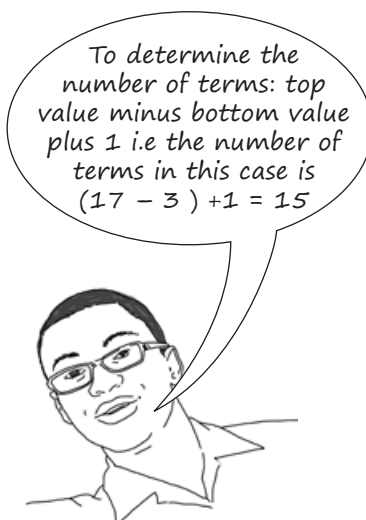

Solutions

1. The question asks you to find the sum of the terms from $n = 4$ to $n = 70$ if the n^{th} term is $2n - 4$.

$$a = T_1 = 2(4) - 4 = 4 \quad \text{Find the first term } a$$

$$T_2 = 2(5) - 4 = 6$$

$$T_3 = 2(6) - 4 = 8$$

So the sequence is 4; 6; 8; ... and this is an arithmetic series. ✓

To check d , calculate $T_2 - T_1$

$$d = T_2 - T_1 = 6 - 4 = 2$$

$$n = (70 - 4) + 1 = 67 \quad \checkmark$$

There are 67 terms

Now we can substitute these values into the formula to find the sum of 67 terms.

$$S_n = \frac{n}{2} [2a + (n - 1)d]$$

$$S_{67} = \frac{67}{2} [2(4) + (67 - 1)2]$$

$$S_{67} = 33.5 [8 + 132] = 4690$$

$$\text{So } \sum_{n=4}^{70} (2n - 4) = 4690 \quad \checkmark$$

(3)

2. This is a geometric series because $5(3)^{k-1}$ has the form ar^{k-1} , $T_1 = 5(3)^{1-1} = 5$;
 $T_2 = 5(3)^{2-1} = 15$; $T_3 = 5(3)^{3-1} = 45$
 $a = 5$; $r = 3$; $n = m$ and $S_m = 65$

$$S_n = \frac{a(r^n - 1)}{r - 1} \quad \checkmark \quad \dots \quad \text{substitute}$$

$$65 = \frac{5(3^m - 1)}{3 - 1} \quad \checkmark$$

$$65 = \frac{5(3^m - 1)}{2} \quad \dots \quad \text{multiply through by 2}$$

$$130 = 5.3^m - 5 \quad \dots \quad \text{add like terms}$$

$$135 = 5.3^m \quad \checkmark \quad \dots \quad \text{divide through by 5}$$

$$27 = 3^m \quad \dots \quad \text{write 27 as a power of 3}$$

$$3^3 = 3^m \quad \dots \quad \text{bases are the same, so the powers are equal}$$

$$\therefore m = 3 \quad \checkmark \quad (4)$$

3. a) T_1, T_3 and T_5 form a sequence with a common ratio of $\frac{1}{2}$, so T_7 is $\frac{1}{16}$. \checkmark
 T_2, T_4 and T_6 form a sequence with a common difference of 3, so T_8 is 13.

b) $S_{50} = 25$ terms of 1st sequence + 25 terms of 2nd sequence

$$S_{50} = \left(\frac{1}{2} + \frac{1}{4} + \frac{1}{8} + \dots \text{ to 25 terms}\right) + (4 + 7 + 10 + 13 + \dots \text{ to 25 terms}) \quad \checkmark$$

$$S_{50} = \frac{\frac{1}{2} \left[\left(\frac{1}{2}\right)^{25} - 1 \right]}{\frac{1}{2} - 1} + \frac{25}{2} [2(4) + 24(3)] \quad \checkmark$$

$$S_{50} = 0,99999997 + 1\,000 \quad \checkmark$$

$$S_{50} \approx 1\,001,00 \quad \checkmark$$

(5)

[12]

3.5.4 Infinite geometric series

An infinite series is one in which there is no last term, i.e. the series goes on without ending.

e.g. 10

$$6 + 3 + \frac{3}{2} + \frac{3}{4} + \dots$$

$$S_{\infty} = \sum_{k=1}^{\infty} 2(3)^{k-1} = 2 + 6 + 18 + 54 + \dots \text{ the sum from term 1 to infinity of } 2(3)^{k-1}$$

$$T_1 = 2(3)^0 = 2$$

$$T_2 = 2(3)^1 = 6$$

$$T_3 = 2(3)^2 = 18$$

$$T_4 = 2(3)^3 = 54 \quad \dots$$

The terms of this series are all positive numbers and the sum will get bigger and bigger without any end. This is called a **divergent** series.

e.g. 11

Look at this infinite series:

$$S_{\infty} = 1 + \frac{1}{2} + \frac{1}{4} + \frac{1}{8} + \frac{1}{16} + \dots$$

$$S_2 = 1 + \frac{1}{2} = 1\frac{1}{2} = 1.5$$

$$S_3 = 1\frac{1}{2} + \frac{1}{4} = 1\frac{3}{4} = 1.75$$

$$S_4 = 1\frac{3}{4} + \frac{1}{8} = 1\frac{7}{8} = 1.675$$

$$S_5 = 1\frac{7}{8} + \frac{1}{16} = 1\frac{15}{16} = \dots$$

This series will converge to 2. It is therefore called a convergent series and we can write the sum to infinity equals 2: $S_{\infty} = 2$

You can identify a convergent infinite series by looking at the value r

An infinite series is convergent if $-1 < r < 1, r \neq 0$

The formula for the sum of a convergent infinite series:

$$S_{\infty} = \frac{a}{1-r}$$

where a is the first term, r is the common ratio

This formula is provided on the information sheet in the final exam.

e.g. 12

1. Look again at the example where $S_{\infty} = 1 + \frac{1}{2} + \frac{1}{4} + \frac{1}{8} + \frac{1}{16} + \dots$
 $a = 1$ and $r = \frac{1}{2}$ $0 < r < 1$

$$S_{\infty} = \frac{a}{1-r}$$

$$S_{\infty} = \frac{1}{1-\frac{1}{2}} = 1 \div \frac{1}{2}$$

$$S_{\infty} = 1 \times 2 = 2$$

2. For which value(s) of x will $8x^2 + 4x^3 + 2x^4 + \dots$ be convergent?

For convergent geometric series, $-1 < r < 1$

$$r = T_2 \div T_1$$

$$= 4x^3 \div 8x^2$$

$$= \frac{x}{2}$$

$$\therefore -1 < \frac{x}{2} < 1 \quad \text{multiply through by 2}$$

$$-2 < x < 2 \dots \dots \dots x \neq 0$$



Activity 7

1. Calculate S_{∞} if $\sum_{p=1}^{\infty} 8(4)^{1-p}$ (3)
2. Given the series: $3(2x-3)^2 + 3(2x-3)^3 + 3(2x-3)^4 + \dots$ for which values of x will the series converge? (4)
3. Find the value of m if: $\sum_{k=1}^m 3(2)^{k-1} = 93$ (4)
4. For which values of x will $\sum_{k=1}^{\infty} (4x-1)^k$ exists. (3)

[14]

Solutions

1. $T_1 = 8(4)^{1-1} = 8 = a$ ✓

To find r , find the common ratio using T_1 and T_2 , T_2 and T_3 .

$$T_2 = 8(4)^{1-2} = 8(4)^{-1} = 8 \times \frac{1}{4} = 2$$

$$T_3 = 8(4)^{1-3} = 8(4)^{-2} = 8 \times \frac{1}{16} = \frac{1}{2}$$

$$T_2 \div T_1 = \frac{2}{8} = \frac{1}{4} \text{ and } T_3 \div T_2 = \frac{\frac{1}{2}}{2} = \frac{1}{2} \times \frac{1}{2} = \frac{1}{4}$$

so $r = \frac{1}{4}$ and $a = 8$ ✓

$$\therefore S_{\infty} = \frac{a}{1-r} = \frac{8}{1-\frac{1}{4}} = \frac{8}{\frac{3}{4}} \checkmark$$

When dividing by a fraction, you can multiply by the inverse

$$= 8 \times \frac{4}{3} = \frac{32}{3}$$

$$\therefore S_{\infty} = \frac{32}{3} \text{ or } 10 \frac{2}{3} \quad (3)$$

2. This is a geometric series with $r = 2x - 3$ ✓

To converge $-1 < r < 1$ ✓

$$-1 < 2x - 3 < 1 \quad \text{Add 3 to both sides}$$

$$2 < 2x < 4 \quad \text{Divide by 2 on both sides}$$

$$1 < x < 2 \checkmark \quad x \neq \frac{3}{2} \checkmark \quad (4)$$

The series will converge for $1 < x < 2$

3. $a = 3; r = 2; S_m = 93$

$$S_n = \frac{a(1-r^n)}{1-r} \checkmark$$

$$93 = \frac{3(1-2^m)}{1-2} \checkmark$$

$$93 = \frac{3(1-2^m)}{-1}$$

$$-93 = 3(1-2^m)$$

$$-31 = 1 - 2^m$$

$$2^m = 32 \checkmark$$

$$2^m = 2^5$$

$$\therefore m = 5 \checkmark \quad (4)$$

4. $r = 4x - 1$ ✓

$$-1 < r < 1$$

$$-1 < 4x - 1 < 1; \quad x \neq \frac{1}{4} \checkmark$$

$$0 < 4x < 2$$

$$0 < x < \frac{1}{2} \checkmark \quad (3)$$

[14]

What you need to be able to do:

- Find the next few terms in a given sequence.
- Identify arithmetic sequences, quadratic sequences and geometric sequences
- Apply knowledge of sequences and series to solve real life problems
- Find the first difference and the second common difference in a quadratic sequence.
- Find the general terms of sequences.
- Know how to derive the formulae for the sum of Arithmetic or Geometric Series.
- Solve problems using these sum formulae.
- Work with the sum of infinite geometric sequences that are convergent.



February/March 2014	Questions 2; 3 and 4
November 2013	Questions 2 and 3
February/March 2013	Questions 2 and 3
February/March 2012	Questions 2, 3 and 4
November 2012	Questions 2, 3 and 4
November 2010	Questions 2 and 3



4

Unit

Functions

4.1 What is a function?

If you are given a set of x -values, you can work out the set of y -values or answers that came from *using a given rule* on each x -value.

So there is a **relationship** between the x -values and the y -values that is described by the rule.

The x -values are the input values and the y -values are the output values. In this flow diagram, the rule is $y = 2x - 1$

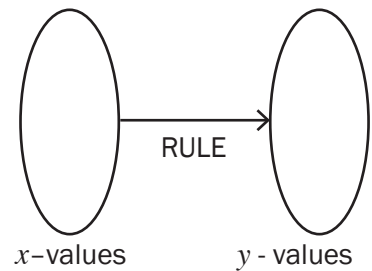

So for every x -value, we multiply it by 2 and subtract 1 to find the corresponding y -value.

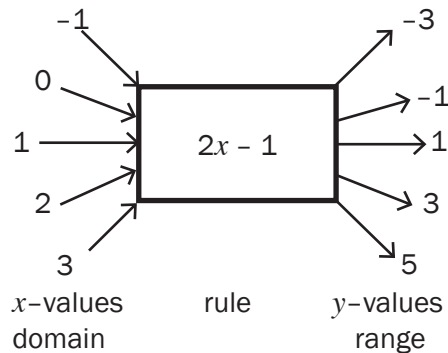

The input values or x -values are the elements of the **domain** of this set and the output values or y -values are the elements of the **range** of this set.

We can plot these values on the Cartesian plane.

If we extend the domain so that $x \in \mathbb{R}$, we get the graph for $y = 2x - 1$.

Look at the graph. For every x -value on this graph, there is only one y -value. If a rule or a formula produces only one y -value for each x -value, then we have a **function**.

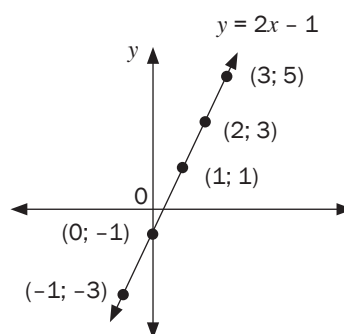

A **function** is a relationship between x and y , where for every x -value there is only one y -value.

One way to decide whether or not a graph represents a function is to use the **vertical line test**.

If any line drawn parallel to the y -axis cuts the graph only once, then the graph represents a function.

e.g. 1

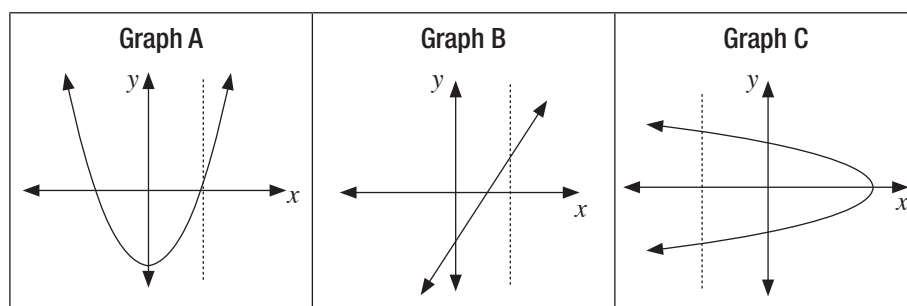

Graph A and Graph B are functions.

Graph C is not a function because the vertical cuts the graph twice. So for an x -value on the graph, there are two y -values.

4.2 Function notation

We use function notation $f(x)$ to show that each y -value is a function of an x -value.

We can also use other letters too, such as $g(x)$, $h(x)$, etc.

So $y = 2x - 1$ can be written as $f(x) = 2x - 1$.

The value of $f(x)$ for any x -value can be worked out by substitution:

For example, at $x = -3$ we can find $f(-3) = 2(-3) - 1 = -7$

So the point $(-3; -7)$ lies on the graph of $f(x) = 2x - 1$



Activity 1

- If $h(x) = \left(\frac{1}{2}\right)^x$ determine the value of $h(-4)$. (3)
 - If the function $g(x) = -x^2 - 3x$, find $g(x + h)$. (2)
 - If $f(x) = 4x + 1$, determine the value of:
 - $f(x + a)$
 - $f(x) + a$
 - $af(x)$ (3)
 - If $g(x) = 2x^2$, determine the value of:
 - $g(-x)$
 - $-g(x)$ (2)
- [10]**

Solutions

1. $h(x) = \left(\frac{1}{2}\right)^x$
 $\therefore h(-4) = \left(\frac{1}{2}\right)^{-4} \checkmark (2^{-1})^{-4} = 2^4 = 16 \checkmark$
 So when $x = -4$, $y = 16$ and the point $(-4; 16)$ lies on the graph of the function $\checkmark h$. (3)

2. $g(x) = -x^2 - 3x$
 $\therefore g(x + h) = -(x + h)^2 - 3(x + h) \checkmark$ wherever there is an x , replace it with $(x + h)$
 $= -(x^2 + 2xh + h^2) - 3x - 3h$
 $= -x^2 - 2xh - h^2 - 3x - 3h \checkmark$

This means that when $x = x + h$, $y = -x^2 - 2xh - h^2 - 3x - 3h$ (2)

3.1 $f(x) = 4x + 1$ 3.2 $f(x) = 4x + 1$ 3.3 $f(x) = 4x + 1$
 $f(x + a) = 4(x + a) + 1$ $f(x) + a = 4x + 1 + a$ $af(x) = a(4x + 1)$
 $= 4x + 4a + 1 \checkmark$ \checkmark $= 4ax + a \checkmark$ (3)

4.1 $g(x) = 2x^2$ 4.2 $g(x) = 2x^2$
 $g(-x) = 2(-x)^2$ $-g(x) = -2x^2 \checkmark$
 $= 2x^2 \checkmark$ (2)

[10]



In each example, there is only one possible y -value for each x -value, so $f(x)$; $h(x)$ and $g(x)$ are functions.

4.3 The basic functions, formulas and graphs

Important terms to remember:

Domain:	the set of possible x -values
Range:	the set of possible y -values
Axis of symmetry:	an imaginary line that divides a graph into two mirror images of each other.
Maximum:	the highest possible y -value of a function.
Minimum:	the lowest possible y -value of a function.
Asymptote:	an imaginary line that a graph approaches but never touches.
Turning point:	The point at which a graph reaches its maximum or minimum value and changes direction.

4.3.1 The linear function (straight line)

Linear functions have the form $f(x) = ax + q$ where a represents the **gradient** of a straight-line graph and q represents the y -intercept when $x = 0$.

The graph of y is a straight line with $a = 1$ and $q = 0$

Domain: $x \in \mathbb{R}$

Range: $y \in \mathbb{R}$

Also note the shape of the following linear functions

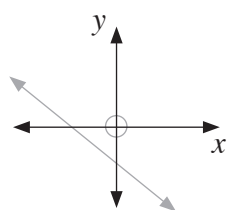
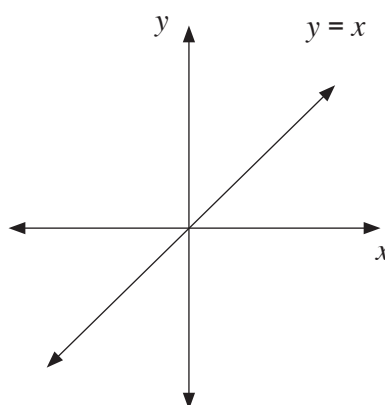

$$a < 0$$

$$q < 0$$

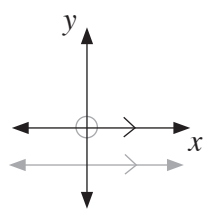

$$a = 0$$

$$y = q$$

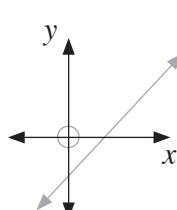

$$a > 0$$

$$q < 0$$

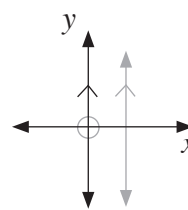

a is undefined
there is no q -value

SKETCHING THE LINEAR FUNCTION

To sketch the linear function using the dual intercept method.

- Determine the x -intercept (let $y = 0$)
- Determine the y -intercept (let $x = 0$)
- Plot these two points and draw a straight line through them.

DETERMINING THE EQUATION OF A LINEAR FUNCTION

To determine the equation of the linear function follow the following steps:

- Determine the gradient of the function.
- Substitute the value of the gradient into the general formula for the linear function.
- Solve for q .
- Write the equation in the form $f(x) = ax + q$

e.g. 2

1.

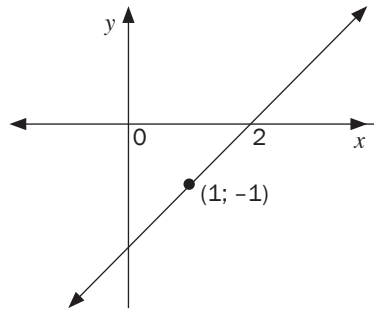

2.

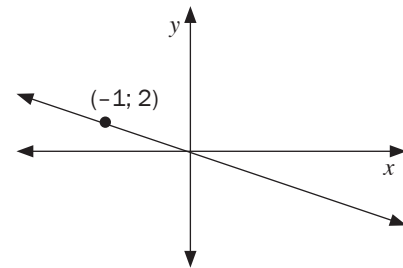
**Solutions**

1.

$$a = \frac{y_2 - y_1}{x_2 - x_1}$$

$$= \frac{-1 - 0}{1 - 2} \quad \checkmark \quad \checkmark$$

$$a = 1$$

$$\therefore y = 1x + c$$

$$0 = 1(2) + c$$

$$c = -2 \quad \checkmark$$

$$\therefore f(x) = x - 2$$

2.

$$a = \frac{y_2 - y_1}{x_2 - x_1}$$

$$= \frac{2 - 0}{-1 - 0} \quad \checkmark$$

$$a = -2$$

$$\therefore y = -2x + c$$

$$0 = -2(0) + c$$

$$c = 0 \quad \checkmark$$

$$\therefore f(x) = x - 2x$$

[5]**4.3.2 The quadratic functions (parabola)**

A **quadratic function** is a **parabola** and can be represented with a general formula $y = ax^2 + bx + c$ or $y = a(x + p)^2 + q$

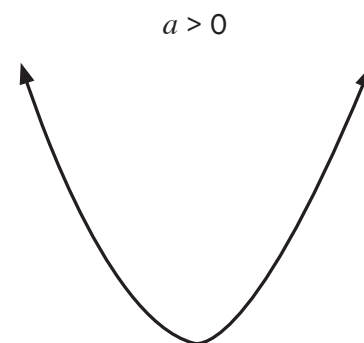
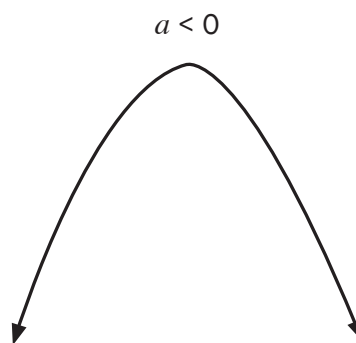
[PROPERTIES OF A PARABOLA]**1. Shape**

- The graph has an axis of symmetry at $x = \frac{-b}{2a}$ or
- The function has one turning point given by $\left(-\frac{b}{2a}; f\left(-\frac{b}{2a}\right)\right)$.
- The function may have either a maximum or a minimum value but never both.
- Domain:** $x \in \mathbb{R}$
Range: $y \geq f\left(-\frac{b}{2a}\right)$ or $y \leq f\left(-\frac{b}{2a}\right)$

SKETCHING THE QUADRATIC FUNCTION

To sketch any quadratic function, follow the following steps:

- Write down the y -intercept (let $x = 0$)
- To calculate the x -intercepts,
 - Write the equation in the form $ax^2 + bx + c = 0$
 - Factorise the left hand side of the equation.
 - Use the fact that if $(x - p)(x - q) = 0$, then $x = p$ or $x = q$, to calculate the x -intercepts.
- Determine the axis of symmetry.
- Substitute the x -value of the axis of symmetry into the original equation of the function to calculate the co-ordinates of the turning point.
- Plot the points and then draw the function using free hand.



Sketch the graph of $f(x) = x^2 - 5x - 6$

1. y -intercept

$$f(0) = -6$$

Therefore the co-ordinates of the y -intercept are $(0; -6)$ ✓

2. x -intercept

$$\begin{aligned} x^2 - 5x - 6 &= 0 && \checkmark \\ (x - 6)(x + 1) &= 0 && \checkmark \\ x &= 6 \text{ or } x = -1 && \checkmark \\ (6; 0) \text{ and } (-1; 0) &&& \end{aligned}$$

3. Axis of symmetry

$$\begin{aligned} x &= \frac{-b}{2a} && \checkmark \\ &= \frac{-(-5)}{2(1)} && \checkmark \\ &= \frac{5}{2} && \checkmark \end{aligned}$$

4. Turning point

$$\begin{aligned} f\left(\frac{5}{2}\right) &= \left(\frac{5}{2}\right)^2 - 5\left(\frac{5}{2}\right) - 6 && \checkmark \\ &= -12\frac{1}{4} && \checkmark \\ \therefore TP &\left(\frac{5}{2}; -12\frac{1}{4}\right) && \checkmark \end{aligned}$$

5. Sketch graph

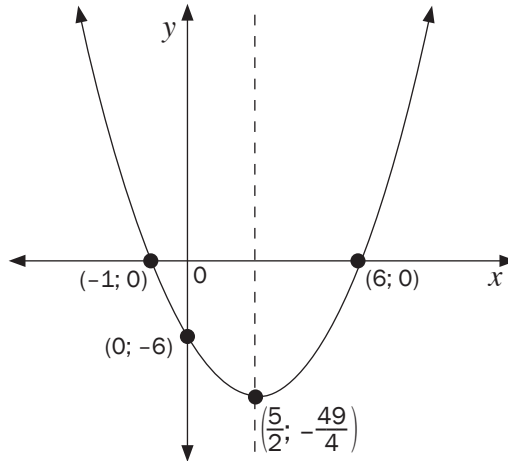

✓x-intercepts ✓y-intercept ✓shape ✓turning point

Determining the equation of a quadratic function

Given the x-intercept and one point	Given the turning point and one point
<ul style="list-style-type: none"> Use the formula: $y = a(x - x_1)(x - x_2)$. Substitute the values of the x-intercepts. Substitute the given point which is not the x-intercept. Solve for a. Write the equation in the form $f(x) = ax^2 + bx + c$. 	<ul style="list-style-type: none"> Use the formula: $y = a(x + p)^2 + q$. Substitute the co-ordinates of the turning point $(p; q)$. Substitute the given point. Solve for a. Write the equation in the form $y = a(x + p)^2 + q$ or $f(x) = ax^2 + bx + c$ depending on the instruction in the question.
Given the co-ordinates of three points on the parabola	
<ul style="list-style-type: none"> Use the formula: $y = ax^2 + bx + c$. One of the given point is the y-intercept, therefore c is given, so substitute its value. Substitute the co-ordinates of the other two points into $y = ax^2 + bx + c$. Solve the two equations simultaneously for a and b. 	

Nature of the roots and the quadratic function

Nature of roots	Quadratic function
Real roots $\Delta > 0$	<p>NOTE: there are two x-intercepts.</p>

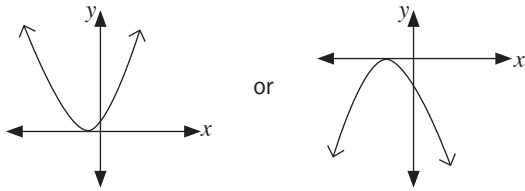
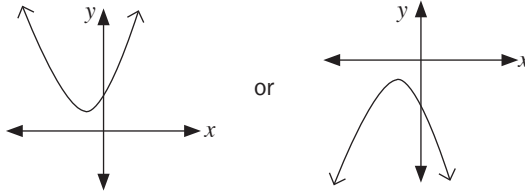
Equal roots $\Delta = 0$	 <p style="text-align: center;">NOTE: there is only one x-intercept.</p>
Non-real roots $\Delta > 0$	 <p style="text-align: center;">NOTE: there are no x-intercepts.</p>



Activity 2

The sketch represents the graph of the parabola given by $f(x) = 2 - x - x^2$.

Points A, B and C are the intercepts on the axes and D is the turning point of the graph.

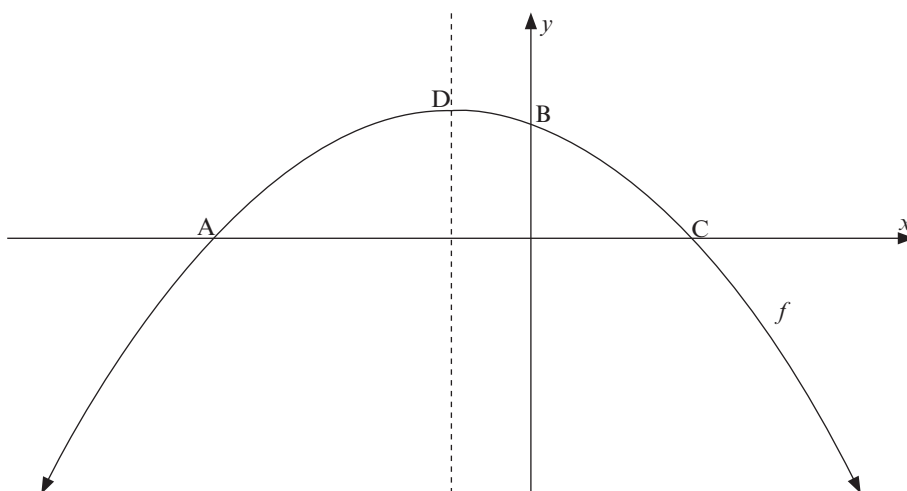

- 1.1 Determine the co-ordinates of A, B and C. (4)
- 1.2 Determine the co-ordinates of the turning point D. (3)
- 1.3 Write down the equation of the axes of symmetry of $f(x-5)$. (1)
- 1.4 Determine the values of x for which $-f(x) \geq 0$. (2)

[10]

Solutions

1.1 B(0; 2)

$$2 - x - x^2 = 0 \quad \checkmark$$

$$x^2 + x - 2 = 0$$

$$(x - 1)(x + 2) = 0 \quad \checkmark$$

$$x = 1 \text{ or } x = -2 \quad \checkmark$$

$$A(-2; 0) \text{ and } C(1; 0) \quad \checkmark$$

(4)

1.2

$$x = \frac{-b}{2a}$$

$$= \frac{-(-1)}{2(-1)} \quad \checkmark$$

$$= -\frac{1}{2} \quad \checkmark$$

$$f\left(-\frac{1}{2}\right) = 2 - \left(-\frac{1}{2}\right) - \left(-\frac{1}{2}\right)^2$$

$$= \frac{9}{4} = 2\frac{1}{4}$$

$$D\left(-\frac{1}{2}; \frac{9}{4}\right) \quad \checkmark$$

(3)

1.3 $x = \frac{9}{2}$ or $x = 4\frac{1}{2}$ ✓

(1)

1.4 $x \leq -2$ ✓ or $x \geq 1$ ✓

(2)

[10]**Activity 3**

The sketch represents the graph of the parabola given by $f(x) = ax^2 + bx + c$ and the straight line defined by $g(x) = mx + c$

Points A, B, C and D are the intercepts on the axes. E is the point of intersection of the two graphs.

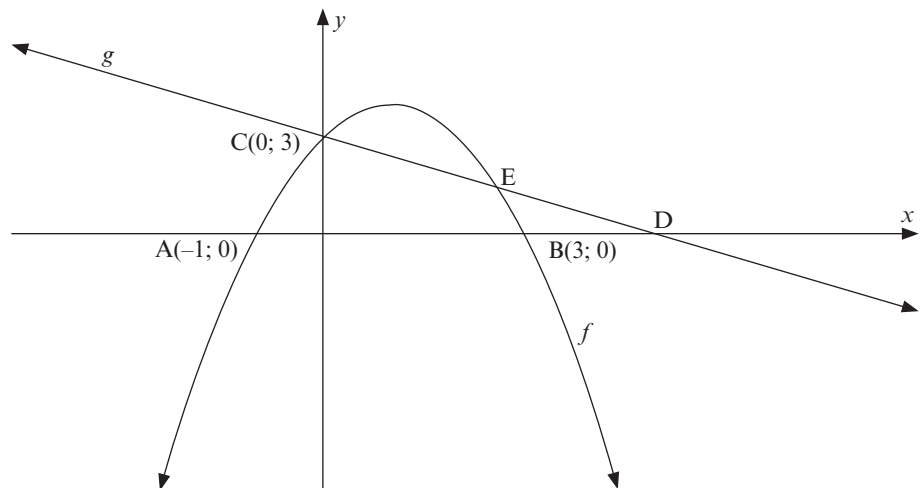

2.1 Write down the co-ordinates of point D if D is the image of B after B has been translated two units to the right. (1)

2.2 Determine the equation of g. (3)

2.3 Determine the equation of the function f in the form $f(x) = ax^2 + bx + c$. (4)

2.4 Determine the coordinates of E. (4)

2.5 Write down the values of x for which $f(x) \geq g(x)$. (2)

[14]

Solutions

2.1 $D(5; 0)$ ✓ (1)

2.2 $g(x) = mx + 3$
 $0 = m(5) + 3$ or $m_g = \frac{3-0}{0-5} = -\frac{3}{5}$ ✓
 $m = -\frac{3}{5}$ ✓
 $g(x) = -\frac{3}{5}x + 3$ ✓ (3)

2.3 $f(x) = a(x+1)(x-3)$ ✓
 $3 = a(0+1)(0-3)$ ✓
 $a = 1$ ✓
 $f(x) = -(x+1)(x-3)$
 $f(x) = -x^2 + 2x + 3$ ✓ (4)

2.4 $-\frac{3}{5}x + 3 = -x^2 + 2x + 3$ ✓
 $x^2 - \frac{13}{5}x = 0$
 $x(x - \frac{13}{5}) = 0$ ✓
 $x = 0$ or $x = \frac{13}{5} = 2,60$ ✓
 $g(\frac{13}{5}) = -\frac{3}{5}(\frac{13}{5}) + 3$
 $= \frac{36}{25}$
 $= 1,44$ ✓
 $\therefore E(\frac{13}{5}; \frac{36}{25})$ or $E(2\frac{3}{5}; 1\frac{11}{25})$ or $E(2,60; 1,44)$ (4)

2.5 $0 \leq x \leq \frac{13}{5}$ ✓✓ (2)

[14]

4.3.3 The hyperbolic function

Hyperbola of the form $y = \frac{a}{x}$ or $xy = a$ where $a \neq 0$; $x \neq 0$; $y \neq 0$.

Properties

Shape

1. $a > 0$

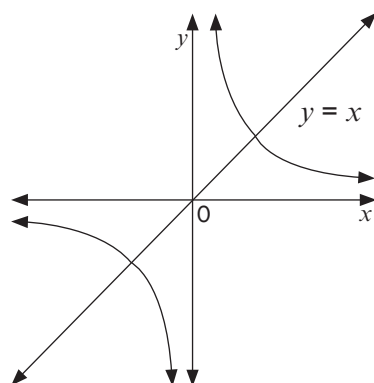

$a < 0$

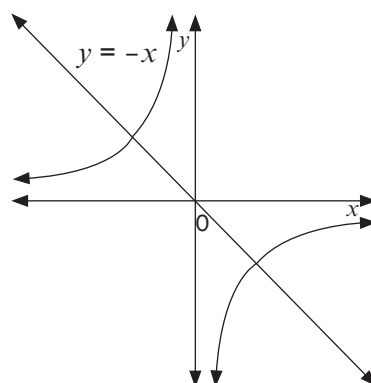

2. (i) Domain : $x \in \mathbb{R}; x \neq 0$ (i) Range: $y \in \mathbb{R}; y \neq 0$
3. The horizontal asymptote is the x -axis
4. The vertical asymptote is the y -axis
5. If $a < 0$, the graph lies in the 2nd and 4th quadrant
6. If $a > 0$, the graph lies in the 1st and 3rd quadrant
7. The lines of symmetry are: $y = x$ and $y = -x$.

SKETCHING THE HYPERBOLA OF THE FORM:

$y = \frac{a}{x}$ or $xy = a$

- The graph does not cut the x -axis and the y -axis (asymptotes)
- Use the table and consider both the negative and positive x -values
- a determine two quadrants where the graph will be drawn



Activity 4

1. Sketch the graph of $y = \frac{1}{x}$ by plotting points. Describe the main features of the graph. (4)

Solution

$a = 1$

$a > 0$, the graph lies in the 1st and 3rd quadrant

-3	-2	-1	$-\frac{1}{2}$	0	$\frac{1}{2}$	1	2	3
$-\frac{1}{3}$	$-\frac{1}{2}$	-1	-2	undefined	2	1	$\frac{1}{2}$	$\frac{1}{3}$

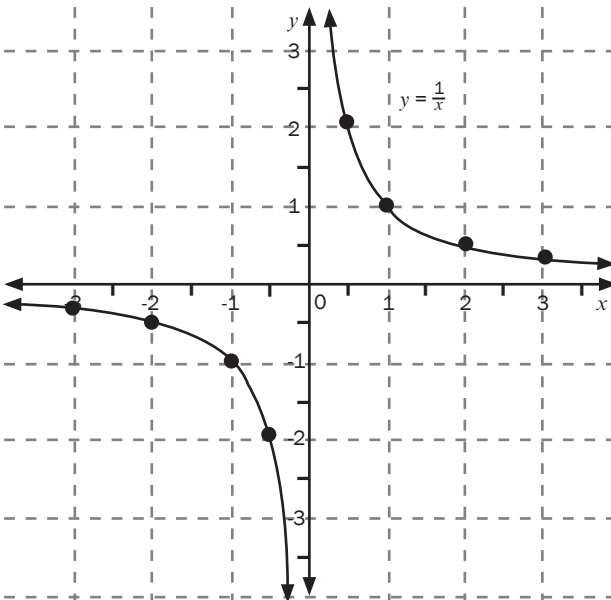

- Domain: $x \in \mathbb{R}; x \neq 0$ ✓
- Range: $y \in \mathbb{R}; y \neq 0$ ✓
- Asymptotes: $x = 0$ and $y = 0$ ✓
- Lines of symmetry $y = x$ and $y = -x$ ✓ (4)

2. Sketch the graph of $y = \frac{-4}{x}$ by plotting the points. Describe the main features of the graphs. (4)

Solution

$a = -4$

$a < 0$, the graph lies in the 2nd and 4th quadrant

-4	-2	-1	0	1	2	4
1	2	4	undefined	-4	-2	-1

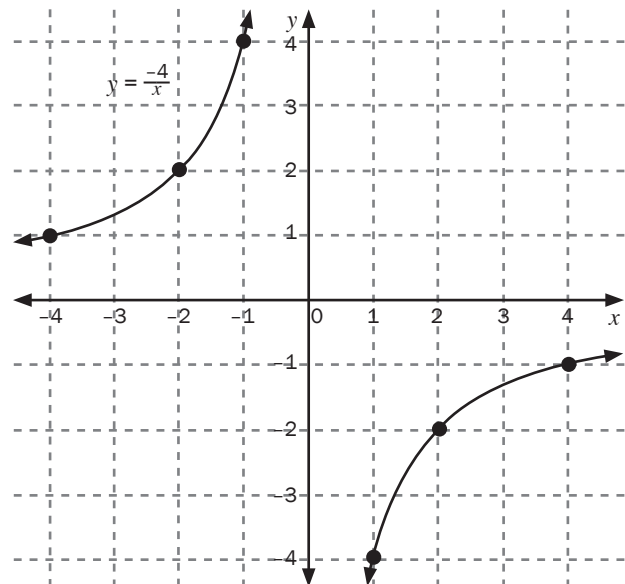

- Domain: $x \in \mathbb{R}; x \neq 0$ ✓
- Range: $y \in \mathbb{R}; y \neq 0$ ✓
- Asymptotes: $x = 0$ and $y = 0$ ✓
- Lines of symmetry $y = x$ and $y = -x$ ✓ (4)

[8]

4.3.4 The hyperbola

Hyperbola of the form $y = \frac{a}{x} + q$ is the translation of the graph of $y = \frac{a}{x}$ vertically by q units.

The Horizontal asymptote (x -axis) will also shift q units vertically (up or down).



Activity 5

1. Consider the function $y = \frac{1}{x} - 2$

1.1 Determine :

- the equations of the asymptotes
- the coordinates of the x -intercepts

1.2 Sketch the graph

1.3 Write down:

- the domain and range
- the lines of symmetry
 $y = x + c$ and $y = -x + c$

(10)

Solutions

1.1

- The horizontal asymptote is $y = -2$ since the graph moved 2 units down and the vertical asymptote is $x = 0$ ✓ denominator cannot equal to zero.

- For x - intercepts let $y = 0$

$$0 = \frac{1}{x} - 2 \quad \checkmark$$

$$0 = 1 - 2x \quad \checkmark \text{ (multiplying by LCD which is } x \text{)}$$

$$2x = 1 \quad \checkmark$$

$$x = \frac{1}{2} \quad \checkmark$$

$$\left(\frac{1}{2}; 0\right)$$

2. Consider the function $f(x) = \frac{-4}{x} + 1$

2.1 Determine:

- the equations of the asymptotes
- the coordinates of the x -intercepts

2.2 Sketch the graph

2.3 Write down the domain and range

- If the graph of f is reflected by the line having the equation $y = -x + c$, the new graph coincides with the graph of $f(x)$.

Determine the value of c .

(9)

Solutions

2.1

- The horizontal asymptote is $y = 1$ ✓ since the graph moved 1 units up and the vertical asymptote is $x = 0$ denominator cannot equal to zero.

- For x -intercepts let $y = 0$

$$0 = \frac{-4}{x} + 1 \quad \checkmark$$

$$0 = -4 + x \quad \checkmark \text{ (multiplying by LCD which is } x \text{)}$$

$$x = 4 \quad \checkmark$$

$$(4; 0)$$

1.2

x	-4	-2	-1	0	1	2	4
y	$-2\frac{1}{4}$	$-2\frac{1}{2}$	-3	undefined	-1	$-1\frac{1}{2}$	$-1\frac{3}{4}$

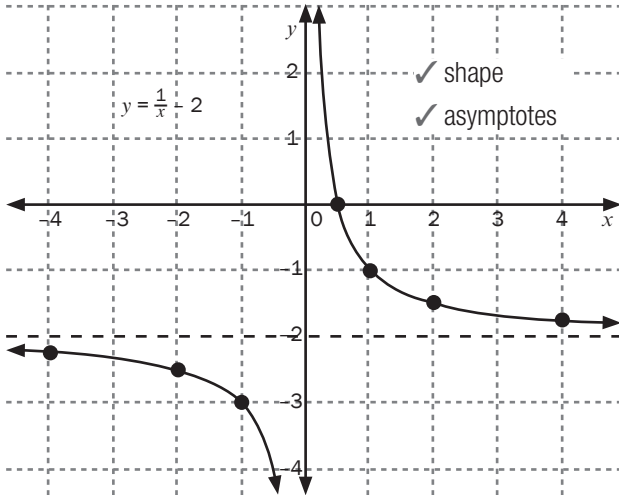

1.3

a) Domain: $x \in \mathbb{R}; x \neq 0$ ✓

Range: $y \in \mathbb{R}; y \neq 2$ ✓

b) $y = x$ and $y = -x$

translation 2 units down therefore

$y = x - 2$ and $y = -x - 2$ ✓

$\therefore c = -2$

Or substitute (0; 2) point of intersection of the two asymptotes in

$y = x + c$ or $y = -x + c$

And calculate the value of c

[10]



Compare this graph with the one in activity 4 (a)

2.2

x	-4	-2	-1	0	1	2	4
y	2	2	5	undefined	-3	-1	0

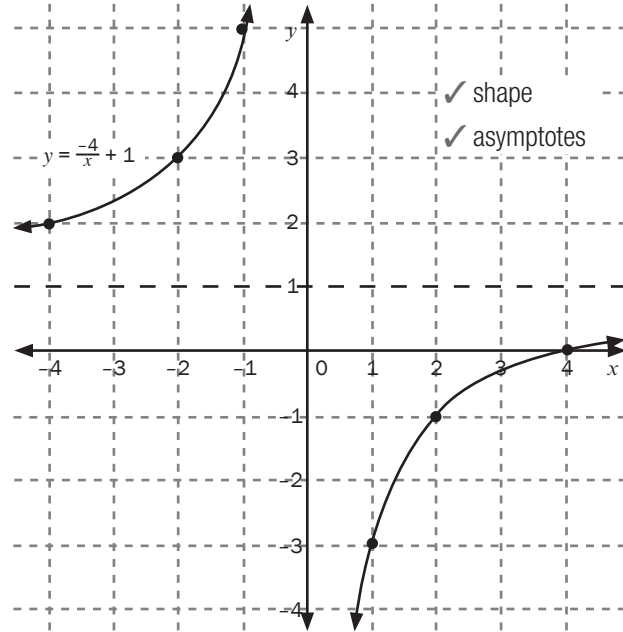

2.3 Domain: $x \in \mathbb{R}; y \neq 0$ ✓

Range: $y \in \mathbb{R}; y \neq 1$ ✓

2.4 The asymptotes are

$x = 0$ and $y = 1$

$y = -x + c$

$1 = -(0) + c$

$1 = c$

lines are $y = -x + 1$ and $y = x + 1$ ✓

[9]



Compare this graph with the one in activity 4 (b)

4.3.5 Hyperbola of the form

$$y = \frac{a}{x+p} + q \text{ where } a \neq 0, x \neq -p, y \neq q$$

1. Shape

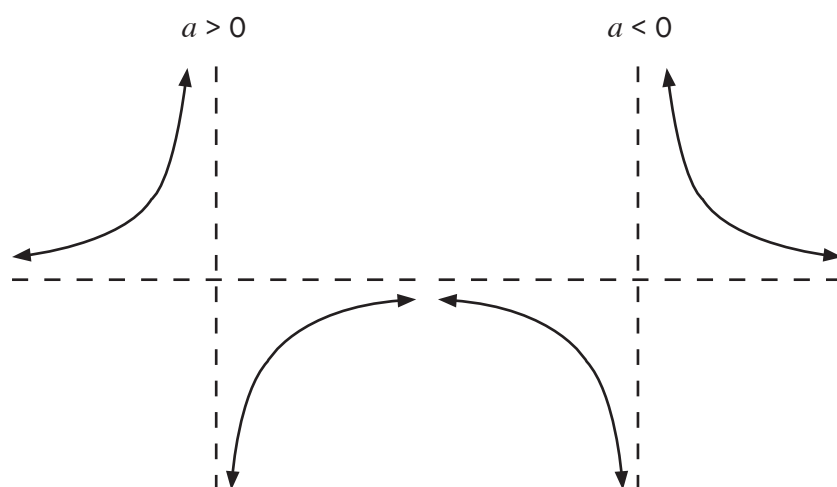

The dotted lines are the asymptotes

- Domain: $x \in \mathbb{R}; x \neq -p$. Range: $y \in \mathbb{R}; y \neq q$
- The **horizontal asymptote** is $y = q$
- The **vertical asymptote** is $x + p = 0 \therefore x = -p$
- The lines of symmetry are $y = x + c$ and $y = x + c$

e.g. 4

Consider $g(x) = \frac{8}{x-2} - 3$ has the horizontal asymptote at $y = -3$ and $x - 2 \neq 0 \therefore x \neq 2$ because if $x = 2$ the denominator of the expression $\frac{8}{x-2}$ would be $\frac{8}{2-2} = \frac{8}{0}$ which is undefined because the denominator is zero.

Thus the graph is undefined for $x - 2 = 0 \therefore x = 2$ is the **vertical asymptote**

The graph $y = \frac{8}{x}$ shift 2 units to the right and 3 units down to form the graph $g(x) = \frac{8}{x-2} - 3$

SKETCHING THE HYPERBOLA OF THE FORM

$$y = \frac{a}{x+p} + q$$

- Write down the asymptotes
- Draw the asymptotes on the set of axes as dotted lines
- Use a to determine the two quadrants where the graph will be drawn
- Determine the x - intercept(s) let $y = 0$
- Determine the y - intercept(s) let $x = 0$
- Plot the points and then draw the graph using free hand



Activity 6

- Consider the function $f(x) = \frac{2}{x-3} + 1$
 - Write down the equations of the asymptotes of f (2)
 - Calculate the coordinates of the x and y -intercepts of f (4)
 - Write the domain and range (2)
 - Sketch the graph of f clearly showing ALL asymptotes and intercepts with the axes. (3)
- Consider the function $f(x) = \frac{3}{x-1} - 2$
 - Write down the equation of the asymptotes. (2)
 - Calculate the coordinates of the intercepts of the graph of f with the axes. (3)
 - Sketch the graph of f clearly showing the intercepts with the axes and the asymptotes. (3)
 - Write down the range of $y = -f(x)$. (1)
 - Describe, in words, the transformation of f to g if $g(x) = \frac{-3}{x+1} - 2$ (2)

[22]

Solution

- $x = 3$ and $y = 1$ ✓✓ (2)
 - $f(x) = \frac{2}{x-3} + 1$
 y -intercept $y = \frac{2}{0-3} + 1 = \frac{1}{3}$ ✓
 $(0; \frac{1}{3})$
 x -intercept $0 = \frac{2}{x-3} + 1$ ✓
 $0 = 2 + 1(x-3)$
 $0 = 2 + x - 3$
 $x = 1 \therefore (1; 0)$ (4)
 - Domain: $x \in \mathbb{R}; x \neq 3$ ✓
Range: $y \in \mathbb{R}; y \neq 1$ ✓ (2)
 - $a > 0$

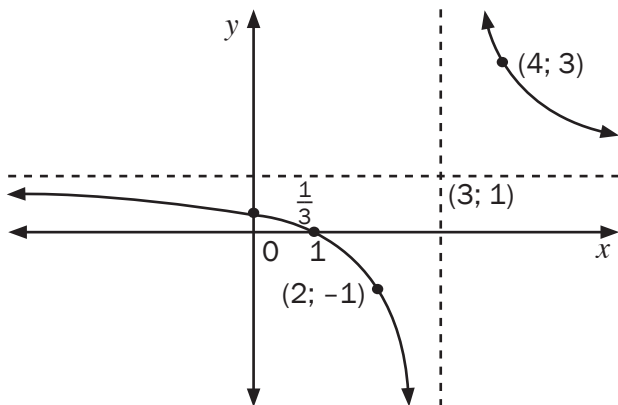

✓ intercepts ✓ asymptotes ✓ shape (3)
[11]

Solution

- $x = -1$ $y = -2$ ✓ (2)
 - y -intercept
 $y = \frac{3}{0-1} - 2 = -5$
 $(0; -5)$
 x -intercept ✓ $0 = \frac{3}{x-1} - 2$
 $2 = \frac{3}{x-1}$
 $2(x-1) = 3$
 $2x - 2 = 3$
 $2x = 5$
 $x = \frac{5}{2}$
 $(\frac{5}{2}; 0)$ (3)
 - $a > 0$

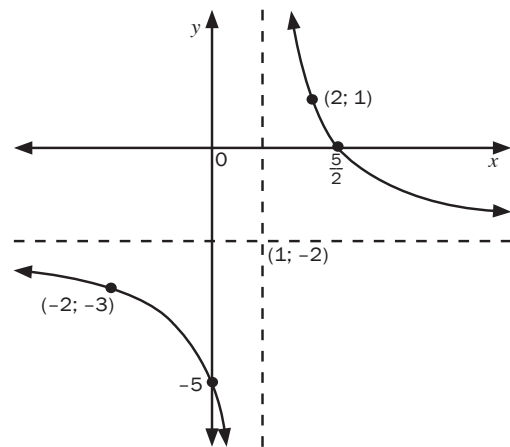

✓ intercepts ✓ asymptotes ✓ shape (3)



In the graph 1 (d) the points $(4; 3)$, $x = 4$ was chosen because it has x -coordinate greater than $x = 3$ the vertical asymptote. The point $(2; -1)$, was chosen because has x -coordinate $x = 2$ is less than $x = 3$ the vertical asymptote. These points can also be used to help determining in which quadrants the graph must be drawn. The points $(2; 1)$ and $(-2; -3)$ on graph 2 (iii) were chosen similarly.

	<p>d) $f(x) = \frac{3}{x-1} - 2$ $-f(x) = -\left(\frac{3}{x-1} - 2\right)$ $-f(x) = \frac{-3}{x-1} + 2$ Range: $y \in \mathbb{R}; y \neq 2$ ✓ (1)</p> <p>e) $g(x) = \frac{-3}{x+1} - 2$ $g(x) = \frac{3}{-x-1} - 2$ Since x is negative this is the reflection ✓ of f about the y-axis ✓ (2)</p> <p>[11]</p>
--	---



Activity 7

The diagram below represents the graph of $f(x) = \frac{a}{x+p} + q$. T(5; 3) is a point on f .

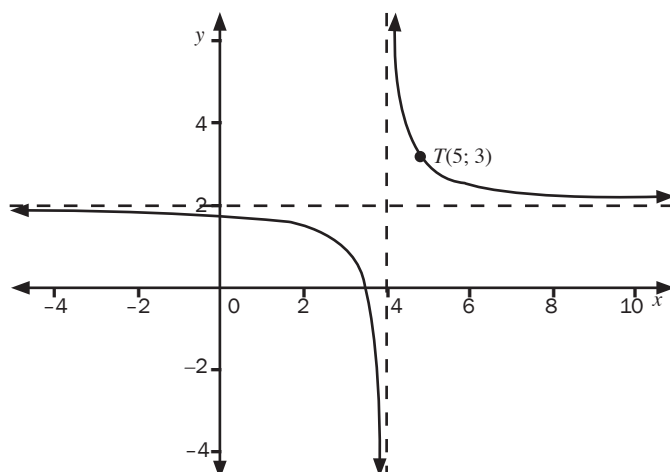

4.1 Determine the values of a , p and q (4)

4.2 If the graph of f is reflected across the line having the equation $y = -x + c$, the new graph coincides with the graph of $y = f(x)$. Determine the value of c . (3)

[7]

Solutions

4.1 ✓ $p = 4$ and $q = 2$ ✓ using the asymptotes

Substitute T(5; 3) into $y = \frac{a}{x-4} + 2$

$$3 = \frac{a}{5-4} + 2 \quad \checkmark \quad 3 = a + 2 \quad a = 1 \quad \checkmark \quad (4)$$

4.2 Substitute (4; 2) ✓ into $y = -x + c$

$$\checkmark 2 = -(4) + c \quad \therefore c = 6 \quad \checkmark \quad (3)$$

[7]



Activity 8

Sketched below are the graphs of $f(x) = (x + p)^2 + q$ and $g(x) = \frac{a}{x+b} + c$. $A\left(2\frac{1}{2}; 0\right)$ is a point on the graph of f . P is the turning point of f . The asymptotes of g are represented by the dotted lines. The graph of g passes through the origin.

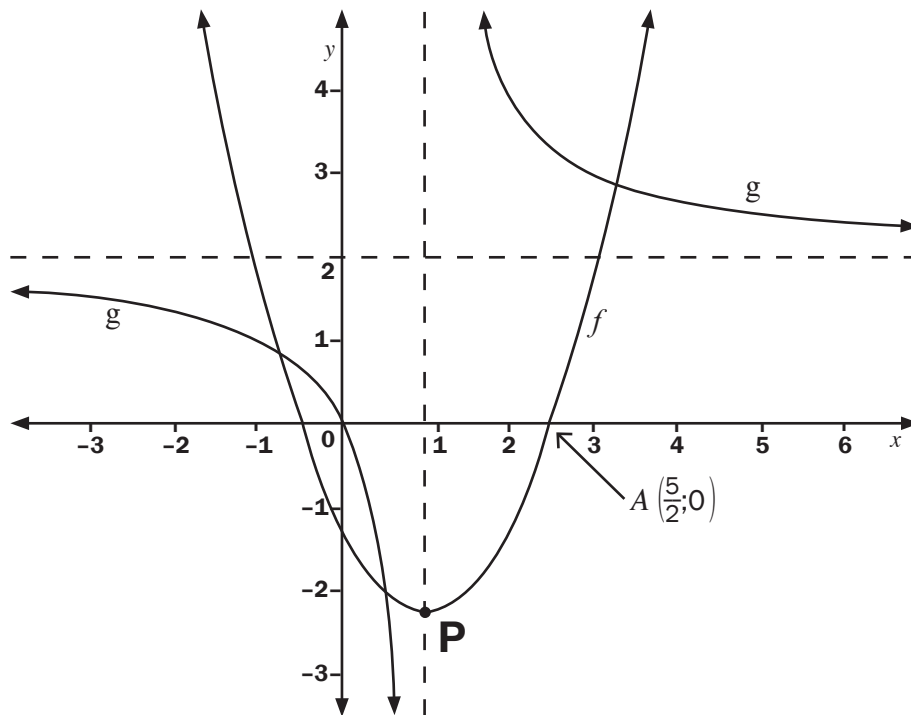

- 5.1 Determine the equation of g . (4)
 5.2 Determine the coordinates of P, the turning point of f . (4)
 5.3 Write down the equation of the asymptotes of $g(x - 1)$. (2)
 5.4 Write down the equation of h , if h is the image of f reflected about the x -axis. (1)
- [11]**

Solutions

5.1 Using the asymptotes $\checkmark b = 1$ and $c = 2 \checkmark$

Substitute $(0; 0)$ into $y = \frac{a}{x-1} + 2$

$$\checkmark 0 = \frac{a}{0-1} + 2 \quad \Rightarrow 0 = -a + 2 \quad \therefore a = 2 \checkmark$$

$$y = \frac{2}{x-1} + 2 \quad (4)$$

5.2 Axis of symmetry $p = 1 \checkmark$

$$f(x) = (x - 1)^2 + q$$

$$\left(\frac{5}{2}; 0\right) \checkmark$$

$$\checkmark 0 = \left(\frac{5}{2} - 1\right)^2 + q$$

$$0 = \frac{9}{4} + q$$

$$q = -\frac{9}{4} \quad \therefore P\left(1; -\frac{9}{4}\right) \checkmark \quad (4)$$

$$5.3 \quad g(x) = \frac{2}{x-1} + 2$$

$$g(x-1) = \frac{2}{(x-1)-1} + 2 \quad \text{substitute } x \text{ with } (x-1)$$

$$g(x-1) = \frac{2}{x-2} + 2$$

$$\checkmark x = 2 \text{ and } y = 2 \checkmark \quad (2)$$

$$5.4 \quad f(x) = (x-1)^2 - \frac{9}{4}$$

Reflection about the x -axis y changes the sign

$$-y = (x-1)^2 - \frac{9}{4}$$

$$y = -\left[(x-1)^2 - \frac{9}{4}\right]$$

$$y = -(x-1)^2 + \frac{9}{4} \checkmark \quad (1)$$

[11]

4.3.6 The exponential function

An **exponential function** can be represented with a general formula $y = ab^{x+p} + q$; $b > 0$

Shape and properties of an exponential function

$y = b^x$; $b > 1$	$y = b^x$; $0 < b < 1$
<ul style="list-style-type: none"> The graph passes through the point $(0; 1)$. Domain: $x \in \mathbb{R}$ Range: $y > 0$ but for $y = b^x + q$, the range will be at $y > q$. The graph is smooth, continuous and an increasing function. Asymptote is at $y = 0$ but for $y = b^x + q$, the horizontal asymptote will be at $y = q$. 	<ul style="list-style-type: none"> The graph passes through the point $(0; 1)$. Domain: $x \in \mathbb{R}$ Range: $y > 0$ but for $y = b^x + q$, the range will be at $y > q$. The graph is smooth, continuous and a decreasing function. Asymptote is at $y = 0$ but for $y = b^x + q$, the horizontal asymptote will be at $y = q$.
<p>NOTE: The two functions are a reflection of each other about the y-axis.</p>	

e.g. 5

Given: $f(x) = 2^x$

- 1.1 Draw the graph of $f(x) = 2^x$, show at least three points on the sketch.
- 1.2 Draw, on the same system of axes the graph of f^{-1} , the inverse of f .
- 1.3 Write down the equation of f^{-1} in the form $y = \dots$

Solutions

1.1 Start by drawing the table:

x	-1	0	1
$f(x)$	0,5	1	2

Then plot the graph using the points

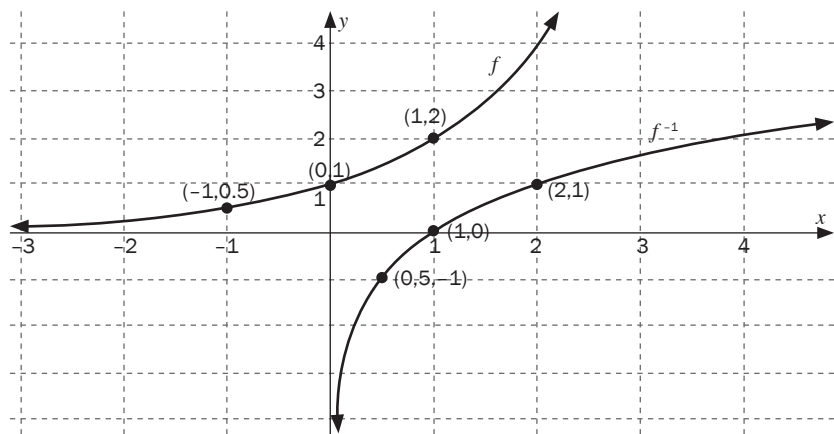

1.2 The sketch of f^{-1} is obtained by interchanging the x and y co-ordinates of f .

1.3 $y = 2^x$

$$x = 2^y \quad \checkmark$$

$$y = \log_2 x \quad \checkmark$$

[2]

e.g. 6

The sketch represents the graph given by $f(x) = a^x$.

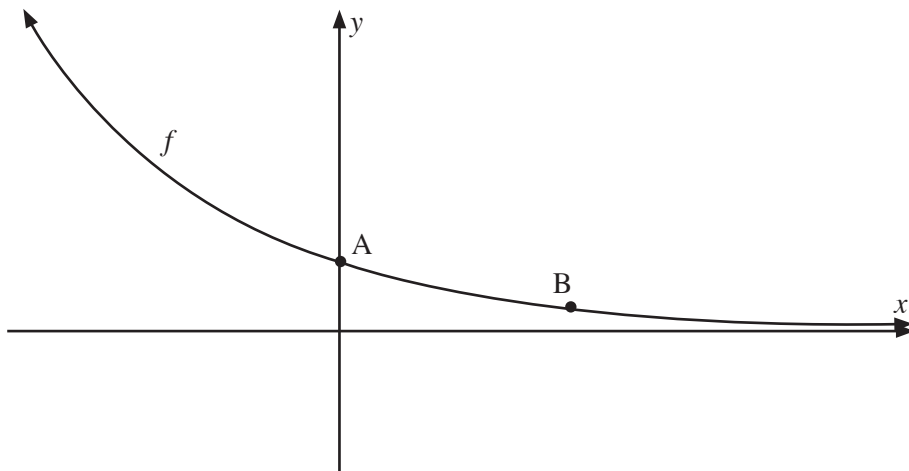

- 2.1 Write down the coordinates of point A. (1)
 2.2 How can we tell that $0 < a < 1$? (1)
 2.3 Determine a if B is the point $(3; \frac{1}{27})$. (2)
 2.4 Determine the equation of the graph obtained if f is reflected about the y -axis. (2)
 2.5 What are the coordinates of the point of intersection of the two graphs? (1)
[7]

Solutions

2.1 $A(0; 1)$ ✓

2.2 Because the graph is a decreasing function. ✓

2.3 $f(x) = a^x$
 $\frac{1}{27} = a^3$ ✓
 $(3^{-1})^3 = a^3$
 $a = \frac{1}{3}$ ✓

2.4 $f(x) = (\frac{1}{3})^x$
 $y = (\frac{1}{3})^x$ becomes $y = (\frac{1}{3})^{-x}$ ✓
 $\therefore y = (3^{-1})^{-x}$
 $y = 3^x$ ✓

2.5 $(0; 1)$ ✓

[7]



Activity 9

The curve of an exponential function is given by $f(x) = k^x$ and cuts the y -axis at A (0; 1) while B $(2; \frac{9}{4})$ lies on the curve.

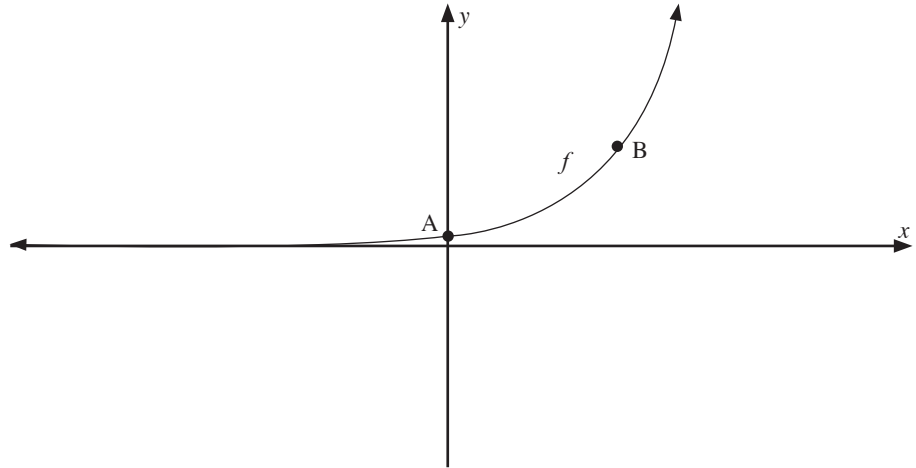

Determine

- 1.1 the equation of the function f . (3)
- 1.2 the equation of the asymptote of h if $h(x) = -f(x)$. (2)
- 1.3 the range of h . (1)
- 1.4 The equation of the function g of which the curve is the reflection of the curve of f in the line $y = x$. (2)

Solutions

1.1 $f(x) = k^x$

$$\frac{9}{4} = a^2 \quad \checkmark$$

$$\left(\frac{3}{2}\right)^2 = a^2 \quad \checkmark$$

$$a = \frac{3}{2} \quad \checkmark \quad \therefore f(x) = \left(\frac{3}{2}\right)^x \quad (3)$$

1.2 $y = 0 \quad \checkmark\checkmark \quad (2)$

1.3 $y \leq 0 \quad \checkmark \quad (1)$

1.4 $g(x) = \log_{\frac{3}{2}} x \quad \checkmark\checkmark \quad (2)$

[8]

4.4 Inverse functions

- The inverse of a function takes the y -values (range) of the function to the corresponding x -values (domain) and vice versa. Therefore the x and y values are interchanged.
- The function is reflected along the line $y = x$ to form the inverse.
- The notation for the inverse of a function is f^{-1} .

e.g. 7

Given $f(x) = 2x + 6$.

- Determine $f^{-1}(x)$
- Sketch the graphs of $f(x)$, $f^{-1}(x)$ and $y = x$ on the same set of axis

Solutions

- In order to find the inverse of a function, there are two steps:

STEP 1: Swap the x and y

$$y = 2x + 6 \quad \checkmark$$

becomes $x = 2y + 6 \quad \checkmark$

We then rewrite the equation to make y the subject of the formula.

Therefore,

STEP 2: make y the subject of the formula

$$x = 2y + 6$$

$$x - 6 = 2y \quad \checkmark$$

$$\text{So } y = \frac{1}{2}x - 3 \quad \checkmark$$

We can say that the inverse function $f^{-1}(x) = \frac{1}{2}x - 3$

-

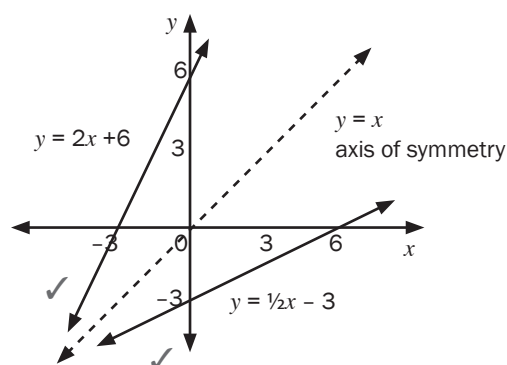

- Every point on the function has the same coordinates as the corresponding point on the inverse function, *except that they are swapped around*.
- Example: $(-3; 0)$ on the function is reflected to become $(0; -3)$ on the inverse function.
- Any point $(a; b)$ on the function becomes the point $(b; a)$ on the inverse.
- To find the equation of an inverse function algebraically, we interchange x and y and then solve for y .
- To draw the graph of the inverse function, we reflect the original graph about the line $y = x$, the axis of symmetry of the two graphs.

e.g. 8

1. a) Sketch $f(x) = 2x^2$
- b) Determine the inverse of $f(x)$
- c) Sketch $f^{-1}(x)$ and $y = x$ on the same axes as $f(x)$

Solution

1. b) $y = 2x^2$

$$x = 2y^2 \quad \checkmark$$

$$y = \pm \sqrt{\frac{x}{2}} \quad \checkmark$$

- This is not a function.
- Check it with a vertical line test. There are two y -values for one x -value.
- Not all inverses of functions are also functions. Some inverses of functions are relations.
- If an inverse is not a function, then we can restrict the **domain** of the **function** in order for the inverse to be a function.
- To make the inverse a function, we need to choose a set of x -values in the function and work only with those. We call this '**restricting the domain**'.
- A one to one function has an inverse that is a function
Example: $y = 3x + 4$ is a one to one function. For every x value there is one and only one y value
The inverse of is a function.
- A many to one function has an inverse that is not a function. However, we can restrict the domain of the function to make its inverse a function.
Example: $y = 2x^2$ is a many to one function. For two or many x values there is one y value. (if $x = 2$, then $y = 8$.
If $x = -2$, then $y = 8$). Therefore, its inverse $y = \pm \sqrt{\frac{x}{2}}$, is not a function.
- To check for a function, draw a vertical line. If any vertical line cuts the graph in only one place, the graph is a function.
If any vertical line cuts the graph in more than one place, then the graph is not a function.
- To check for a one-to-one function, draw a horizontal line. If any horizontal line cuts the graph in only one place, the graph is a one-to-one function. If any horizontal line cuts the graph in more than one place, then the graph is a many-to-one function.

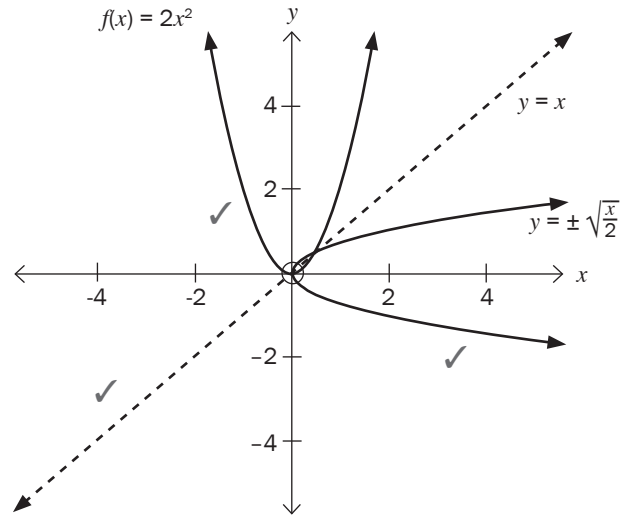

[5]



Activity 10

1. a) If $f(x) = -3x^2$, write down the equation for the inverse function in the form $y = \dots\dots\dots$ (2)
- b) Determine the domain and range of $f(x)$ and $f^{-1}(x)$ (4)
- c) Determine the points of intersection of $f(x)$ and $f^{-1}(x)$ (4)
2. a) If $g(x) = 3x + 2$, find $g^{-1}(x)$ (2)
- b) Sketch g , g^{-1} and the line $y = x$ on the same set of axes. (3)

[15]

Solutions1. a) For $f(x) = -3x^2$.

$$f^{-1}(x): x = -3y^2 \quad \checkmark$$

$$-\frac{x}{3} = y^2$$

$$y = \pm \sqrt{-\frac{x}{3}} \quad \checkmark$$

(2)

b)

	$f(x)$	$f^{-1}(x)$
Domain	$x \in \mathbb{R} \quad \checkmark$	$x \geq 0 \quad \checkmark$
Range	$y \geq 0 \quad \checkmark$	$y \in \mathbb{R} \quad \checkmark$

(4)

c) To determine the points of intersection, we equate the two equations.

The line $y = x$, the axis of symmetry of $f(x)$ and $f^{-1}(x)$, can also be used to determine the points of intersection of $f(x)$ and $f^{-1}(x)$.

$$y = x \text{ and } f(x) = -3x^2$$

$$\therefore x = -3x^2$$

$$\therefore 3x^2 + x = 0 \quad \checkmark$$

$$\therefore x(3x + 1) = 0 \quad \checkmark$$

$$\therefore x = 0 \text{ or } x = -\frac{1}{3} \quad \checkmark$$

$$\text{Substitute } x = 0 \text{ in } y = x \therefore y = 0 \therefore (0; 0) \quad \checkmark$$

$$\text{Substitute } x = -\frac{1}{3} \text{ in } y = x \therefore y = -\frac{1}{3} \therefore \left(-\frac{1}{3}; -\frac{1}{3}\right)$$

(4)

2. a) $g(x) = 3x + 2 \quad \checkmark$ For $g^{-1}(x)$, $x = 3y + 2$

$$x - 2 = 3y$$

$$y = \frac{x-2}{3}$$

$$y = \frac{x}{3} - \frac{2}{3} \quad \checkmark$$

b)

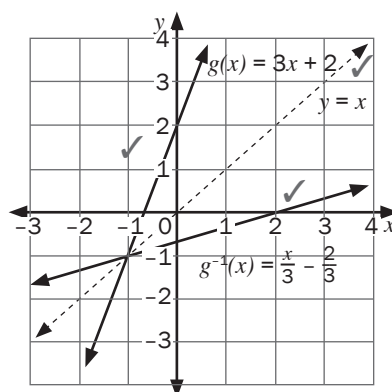

(4)

[15]**Given:** $g(x) = -x^2$ where $x \leq 0$ and $y \leq 0$ (a) Write down the inverse of g , g^{-1} in the form $h(x) = \dots\dots\dots$ (3)(b) Sketch the graphs of g , h and $y = x$ on the same set of axis. (4)**Solutions**(a) $y = -x^2$

$$x = -y^2$$

$$-x = y^2 \quad \checkmark$$

$$\pm \sqrt{-x} = y \quad \checkmark$$

$$-\sqrt{-x} = y \text{ where } x \leq 0 \text{ and } y \leq 0$$

$$\therefore h(x) = -\sqrt{-x} \quad \checkmark$$

(3)

(b)

For g correct shape ✓ and the intercept ✓
 For h correct shape ✓ and the intercept ✓

(4)
 [7]

4.5 The logarithmic function

- $y = \log_x a$ is a logarithmic function with $a = \log$ number, $x = \log$ base
- $y = \log_x a$ Reads “ y is equal to log a base x ”
- The logarithmic function is only defined if $a > 0$, $a \neq 1$ and $x > 0$
- An exponential equation can be written as a logarithmic equation and vice versa

e.g. 9

Write each of the following exponential equations as logarithmic equations:

- $2^6 = 64$
- $5^3 = 125$

Solutions

- $2^6 = 64$
 $\therefore 6 = \log_2 64$
- $5^3 = 125$
 $\therefore 3 = \log_5 125$

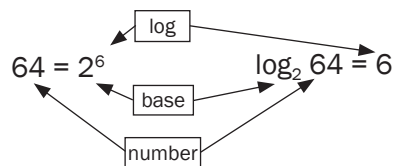

The inverse of the exponential function $y = a^x$ is $x = a^y$

In order to make y the subject of the formula, $x = a^y$, we use the **log function**.

$y = \log_a x$ is the inverse of $y = a^x$.

e.g. 10

Given: $f(x) = 2^x$

- Determine f^{-1} in the form $y = \dots$
- Sketch the graphs of $f(x)$, $f^{-1}(x)$ and $y = x$ on the same set of axes.
- Write the domain and range of $f(x)$ and $f^{-1}(x)$

Solutions

a) The inverse of the exponential function $y = 2^x$ is $x = 2^y$ which can be written as $y = \log_2 x$. ✓

b) To plot the graph, use a table of values:

First make a table for $y =$

x	-2	-1	0	1	2	3
$y = 2^x$	$\frac{1}{4}$	$\frac{1}{2}$	1	2	4	8

Make a table for $y = \log_2 x$

x	$\frac{1}{4}$	$\frac{1}{2}$	1	2	4	8
$y = \log_2 x$	-2	-1	0	1	2	3

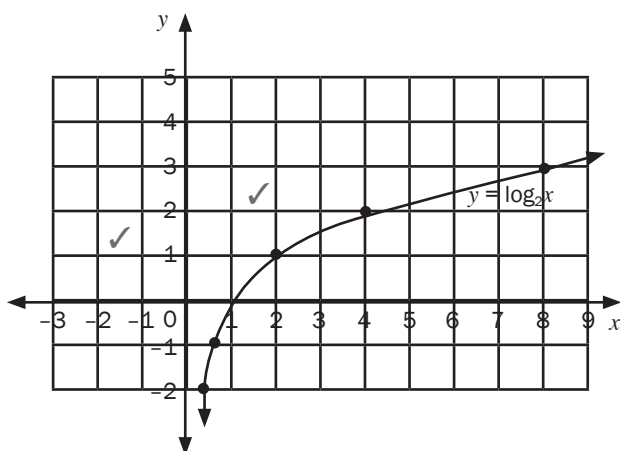

[3]

Let's compare the two graphs on the Cartesian plane.

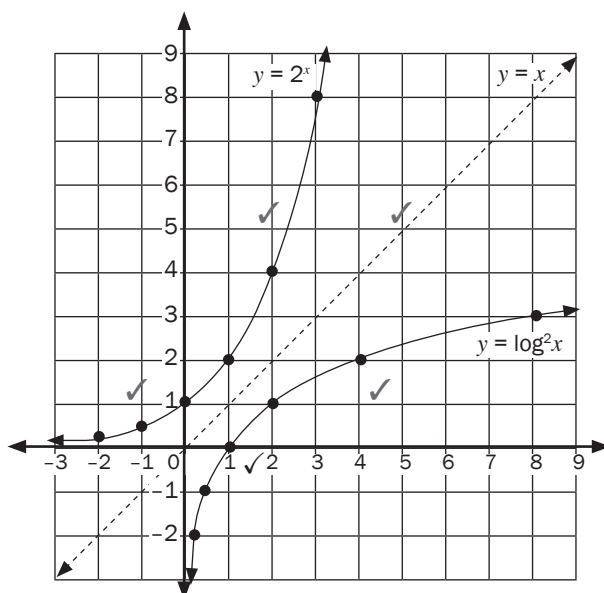

The graph of $y = \log_2 x$ is a **reflection** about the $y = x$ axis of the exponential graph of $y = 2^x$.



Activity 11

The graph of $h(x) = a^x$ is sketched below. $A(-1; \frac{1}{2})$ is a point on the graph of h .

1. Explain why the coordinates of Q are $(0; 1)$. (2)
2. Calculate the value of a . (2)
3. Write down the equation for the inverse function, h^{-1} in the form $y = \dots$ (1)
4. Draw a sketch graph of h^{-1} . Indicate the coordinates of two points that lie on this graph. (2)
5. Read off from your graph the values of x for which $\log_2 x > -1$. (1)

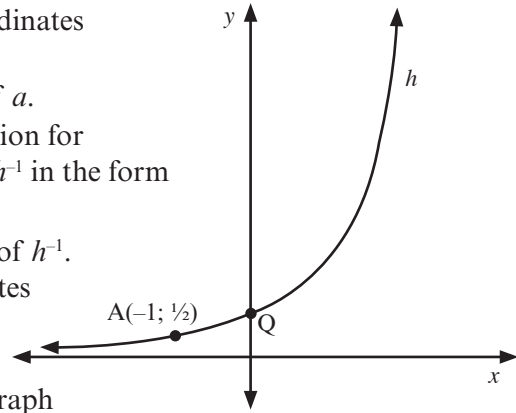

[8]

Solutions

1. $h(0) = a^0 = 1$. ✓ Any base raised to the power of 0 is 1. ✓ (2)
2. $h(x) = a^x$ and $A(-1; \frac{1}{2})$ so $a^{-1} = \frac{1}{2}$ ✓
 $a^{-1} = 2^{-1}$ so $a = 2$ ✓ and $y = 2^x$ (2)
3. Interchange x and y , so $x = 2^y$ and $y = \log_2 x$ ✓ (1)

4.

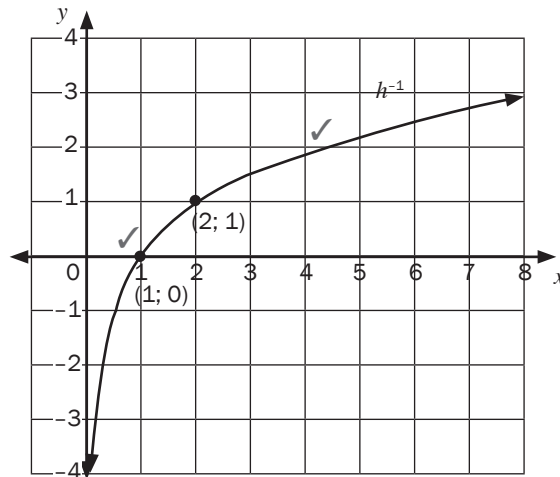

(2)

5. $x > 0.5$ ✓ (1)

[8]

What you need to be able to do:

- Understand the concept of the inverse of a function and find the equations of the inverses.
- The line $y = x$ is the line of symmetry of the function and the inverse of the function
- The logarithmic function and the exponential function are inverse functions of each other.
- If the inverse is not a function, restrict the domain of a function in order to make the inverse a function
- Identify axes of symmetry for parabolas and hyperbolas
- Sketch the graphs of different functions using their characteristics e.g. asymptotes, x - and y -intercepts and turning points
- Determine the functions equations from a graph
- Solve problems involving two or more graphs
- Understand the concept of the inverse of a function and the equation of the inverses
- The line $y = x$ is the line of symmetry of the function and the inverse of the function
- The logarithmic functions and the exponential function are inverse function of each other
- If the inverse is not a function, restrict the domain of a function in order to make the inverse a function.



5 Unit

Trig functions

5.1 Graphs of trigonometric functions

Graph 1. The sine function: $y = a \sin b(x + p) + q$

e.g. 1

Sketch the graph of $y = \sin x$ for x

- We can make use of a table or a calculator to determine the critical points on the graph.
- The endpoints of the domain must be included i.e. $x = -360^\circ$ and $x = 360^\circ$
- All intercepts with the x and y axis must be indicated as well as all minimum and maximum points (turning points)

Solution

x	-360°	-270°	-180°	-90°	0°	90°	180°	270°	360°
y	0	1	0	-1	0	1	0	-1	0

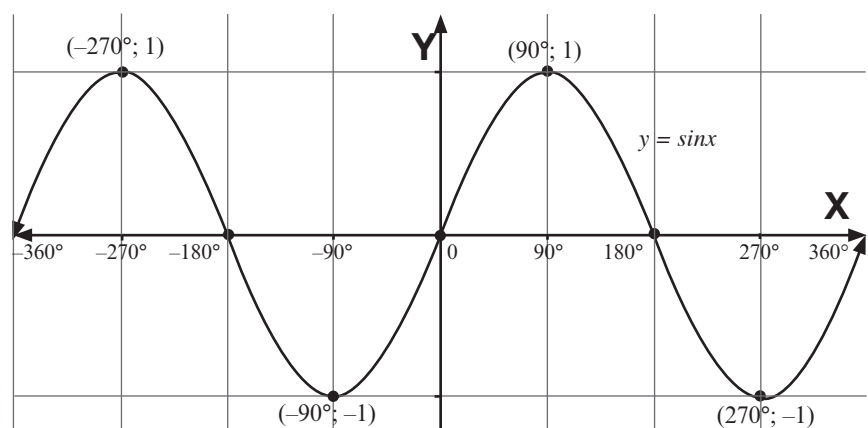

Domain: all the possible x values on the graph
 Range: all the possible y -values on the graph
 Amplitude: the maximum distance from the equilibrium position
 Period: number of degrees to complete a wave or a cycle.

To ensure that all the critical values are indicated on the graph, we have to use the correct x -values.

If $y = a \sin bx$, then $\frac{90^\circ}{b}$ will give us the intervals we have to use from 0. In our example $b = 1$, therefore $\frac{90^\circ}{1} = 90^\circ$.

Therefore we will use x -values of $(0^\circ, 90^\circ, 180^\circ, 270^\circ, 360^\circ \text{ etc})$

If we use a calculator, we will use 90 as the "step".





Activity 1

Use the graph $y = \sin x$ above to answer these questions:

1. What are the maximum and minimum values of $y = \sin x$? (2)
2. Write down the domain and the range of $y = \sin x$. (4)
3. Write down the x -intercepts of $y = \sin x$. (2)
4. What is the amplitude of the graph of $y = \sin x$? (1)
5. What is the period of the graph of $y = \sin x$? (1)

[10]

Solutions		
	$y = \sin x$	
1	Maximum Values	1 ✓, at $x = -270^\circ$ and 90°
	Minimum Values	-1 ✓, at $x = -90^\circ$ and 270° (2)
2	Domain	$x \in [-360^\circ; 360^\circ]$, $x \in \mathbb{R}$ ✓✓
	Range	$[-1; 1]$ $y \in \mathbb{R}$ ✓✓ (4)
3	x -intercepts	$-360^\circ, -180^\circ, 0^\circ, 180^\circ$ and 360° . ✓✓ (2)
4	Amplitude	1 ✓ (1)
5	Period	360° ✓ (1)

[10]

Graph 2. The cosine function:

$$y = a \cos b(x + p) + q$$

e.g. 2

Sketch the graph of $y = \cos x$ for $x \in [-360^\circ; 360^\circ]$

- We can make use of a table or a calculator to determine the critical points on the graph.
- The endpoints of the domain must be included i.e. $x = -360^\circ$ and $x = 360^\circ$
- All intercepts with the x and y axis must be indicated as well as all minimum and maximum points (turning points)

x	-360°	-270°	-180°	-90°	0°	90°	180°	270°	360°
y	1	0	-1	0	1	0	-1	0	1

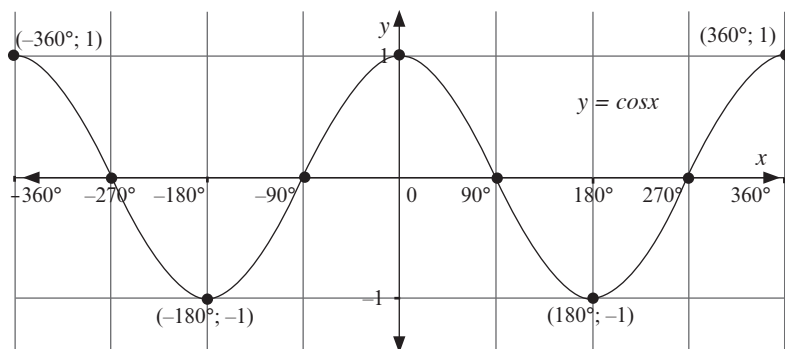

To ensure that all the critical values are indicated on the graph, we have to use the correct x -values.

If $y = a \cos bx$, then $\frac{90^\circ}{b}$ will give us the intervals we have to use from 0° . In our example $b = 1$, therefore $\frac{90^\circ}{1} = 90^\circ$.

Therefore we will use x -values of $(0^\circ, 90^\circ, 180^\circ, 270^\circ, 360^\circ)$ etc)

If we use a calculator, we will use 90° as the "step".



To ensure that all the critical values are indicated on the graph, we have to use the correct x -values. If $y = a \tan bx$, then $\frac{45^\circ}{b}$ will give us the intervals we have to use from 0. In our example $b = 1$, therefore $\frac{45^\circ}{1} = 45^\circ$. Therefore we will use x -values of $(0^\circ, 45^\circ, 90^\circ, 135^\circ \text{ etc})$ If we use a calculator, we will use 45° as the "step"



$y = \cos x$		
1	Maximum Values	1, at $x = 0^\circ$ and 360°
2	Minimum Values	-1, at $x = -180^\circ$ and 180°
3	x -intercepts	$-270^\circ, -90^\circ, 90^\circ$ and 270° .
4	Amplitude	1
5	Period	360°
6	Domain	$x \in [-360^\circ; 360^\circ], x \in \mathbb{R}$
7	Range	$[-1; 1], y \in \mathbb{R}$

Graph 3. The tangent function:

$$y = a \tan b(x + p) + q$$

e.g. 3

Sketch the graph of $y = \tan x$ for $x \in [-180^\circ; 180^\circ]$

- All intercepts with the x and y axis must be indicated.
- The endpoints of the domain must be included i.e. $x = -180^\circ$ and $x = 360^\circ$
- The equations of the asymptotes must be written on the graph.

Solution

x	-180°	-135°	-90°	-45°	0°	45°	90°	135°	180°	225°	270°	315°	360°
y	0	1	undefined	-1	0	1	undefined	-1	0	1	undefined	-1	0

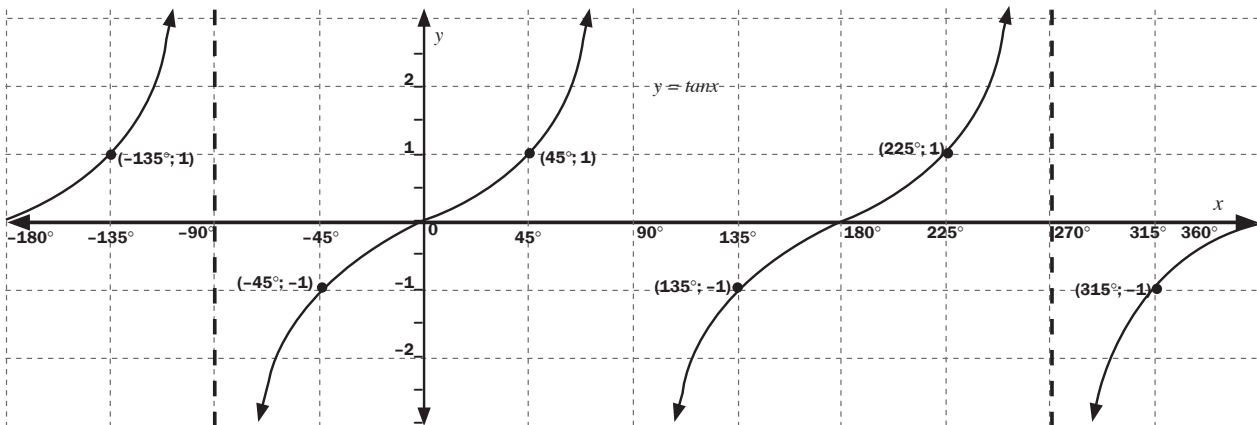

$y = \tan x$		
1	Asymptotes	$x = -90^\circ, x = 90^\circ$ and $x = 270^\circ$
2	x -intercepts	$-180^\circ, 0^\circ, 180^\circ$ and 360° .
3	Period	180°
4	Domain	$x \in [-180^\circ; 360^\circ], x \in \mathbb{R}$
5	Range	$(-\infty; \infty), y \in \mathbb{R}$

5.2 The effect of a on the shape of the graph: change in amplitude

Consider the graphs of $y = a \sin x$, $y = a \cos x$ and $y = a \tan x$

e.g. 4

1. Sketch the following graphs:
 - a) on the same set of axes
 $y = -\sin x$ and $y = 2\sin x$ for $x \in [-360^\circ; 360^\circ]$,
 - b) on the same set of axes
 $y = -2 \cos x$ and $y = \frac{1}{2} \cos x$ for $x \in [-360^\circ; 360^\circ]$,
 - c) $y = 2 \tan x$ for $x \in [-180^\circ; 180^\circ]$,

Solutions

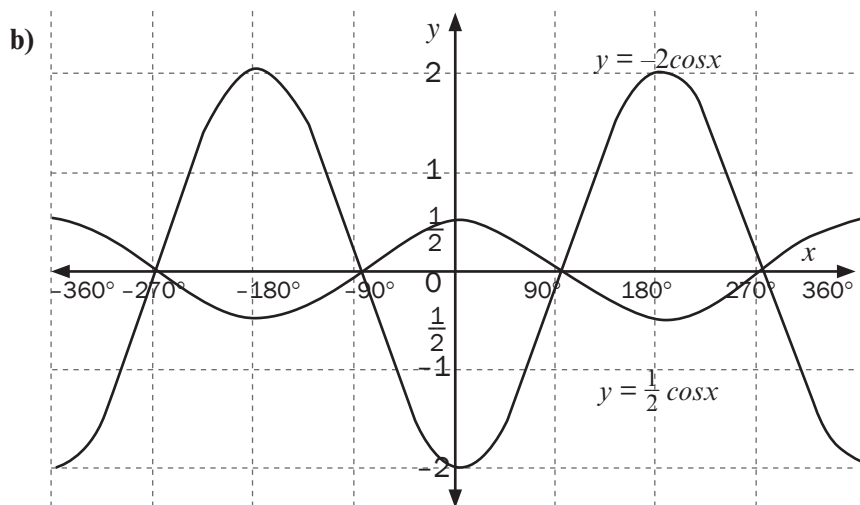
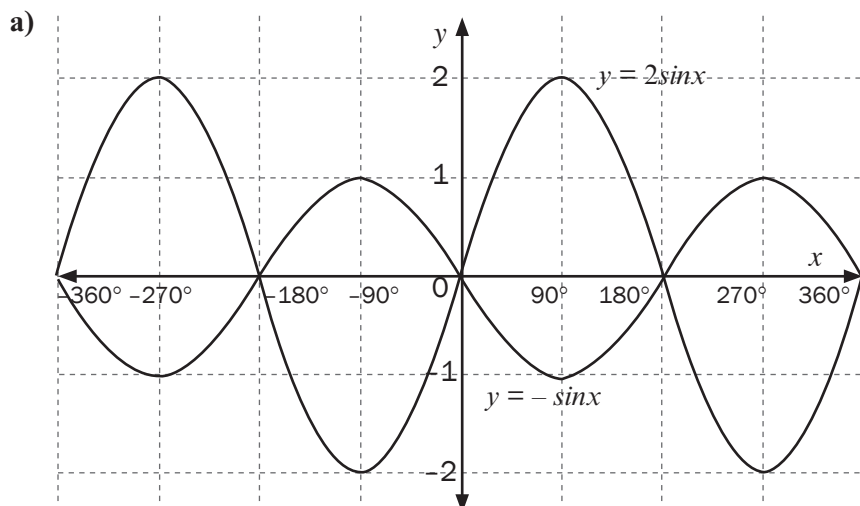

$y = -1\sin x \dots$
 Amplitude = 1
 $y = 2\sin x \dots$ Amplitude = 2
 $y = \sin x \dots$ Amplitude = 1
 $y = a\sin x \dots$ Amplitude = a
 (The amplitude value is always positive, irrespective if a is negative..
 Example: if $a = -2$, then the amplitude is 2.
 The parameter a changes the amplitude of the graph.

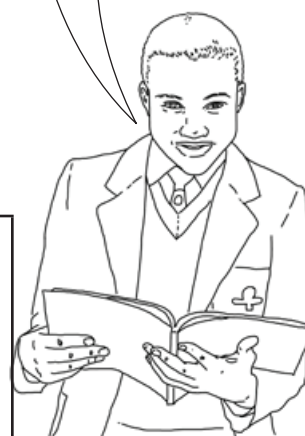

$y = -2 \cos x \dots$
 Amplitude = 2
 $y = \frac{1}{2} \cos x \dots$ Amplitude = $\frac{1}{2}$
 $y = \cos x \dots$ Amplitude = 1
 $y = a \cos x \dots$ Amplitude = a
 The parameter a changes the amplitude of the graph.



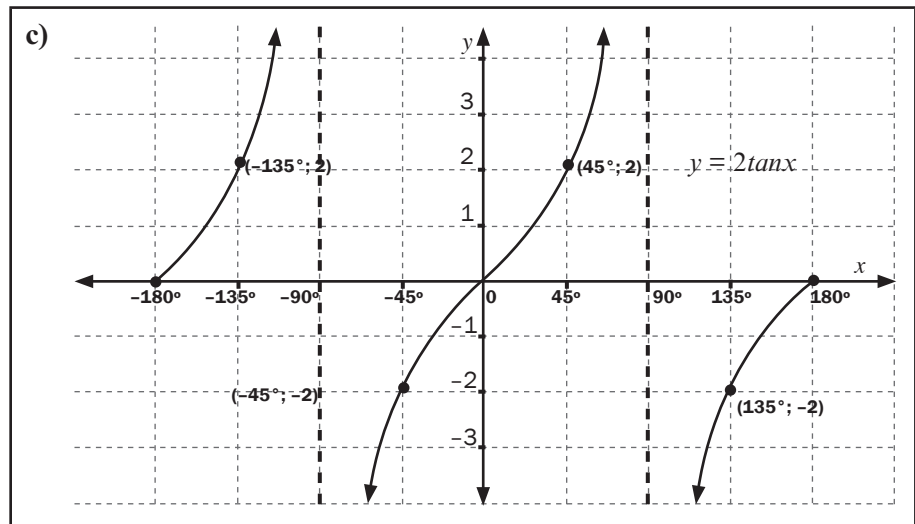

Conclusion

The parameter a changes the **amplitude** of the graph in $y = a\sin bx$ and $y = a\cos bx$.

The graph $y = a\tan bx$ has no maximum or maximum value. The value does not change the amplitude of $y = a\tan bx$ as there is no amplitude.

The value of a affects the y -value of each point. Each y -value is multiplied by a .



5.3 The effect of q on the shape of the graph: vertical shift

Consider the graphs of $y = \sin x + q$, $y = \cos x + q$ and $y = \tan x + q$.

e.g. 5

- Sketch the following graphs on the same set of axes for the domain $[-360^\circ; 360^\circ]$:
 - $y = -\sin x$ and $y = -\sin x + 1$
 - $y = \cos x$, $y = \cos x + 1$, $y = \cos x - 2$
 - $y = \tan x$ and $y = \tan x + 1$

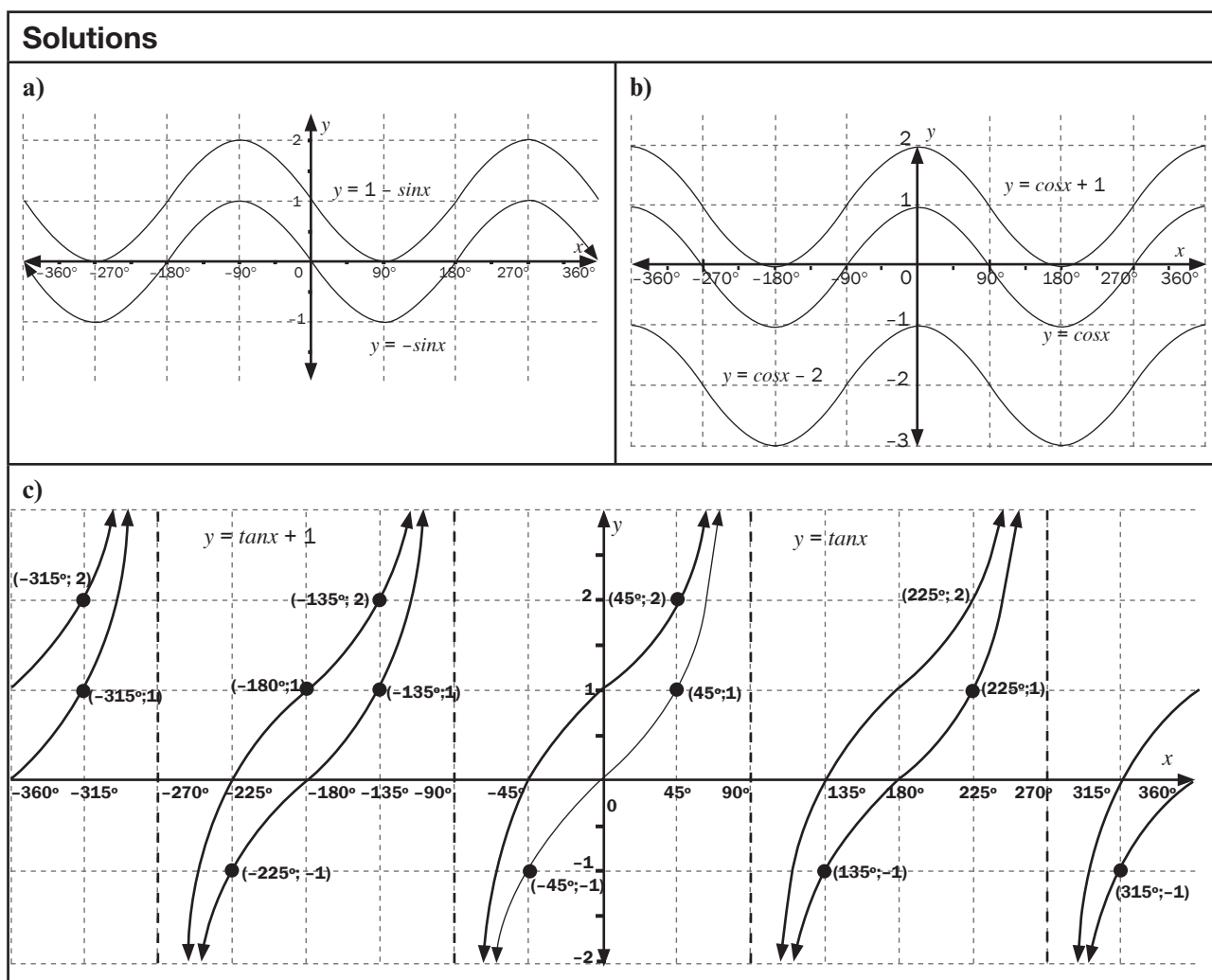

Conclusion

The parameter q shifts the whole graph up or down by q units.

5.4 The effect of b on the shape of the graph: change in period

Consider the graphs of $y = \sin bx$, $y = \cos bx$ and $y = \tan bx$.

e.g. 6

1. Draw the graphs on separate set of axes:

- $y = \sin 2x$ for $x \in [-90^\circ, 180^\circ]$
- $y = \cos 3x$ for $x \in [0^\circ; 360^\circ]$
- $y = \tan \frac{1}{2}x$ for $x \in [-360^\circ; 360^\circ]$

Solutions

1. a) For $y = \sin 2x$, the period is $360^\circ \div 2 = 180^\circ$.

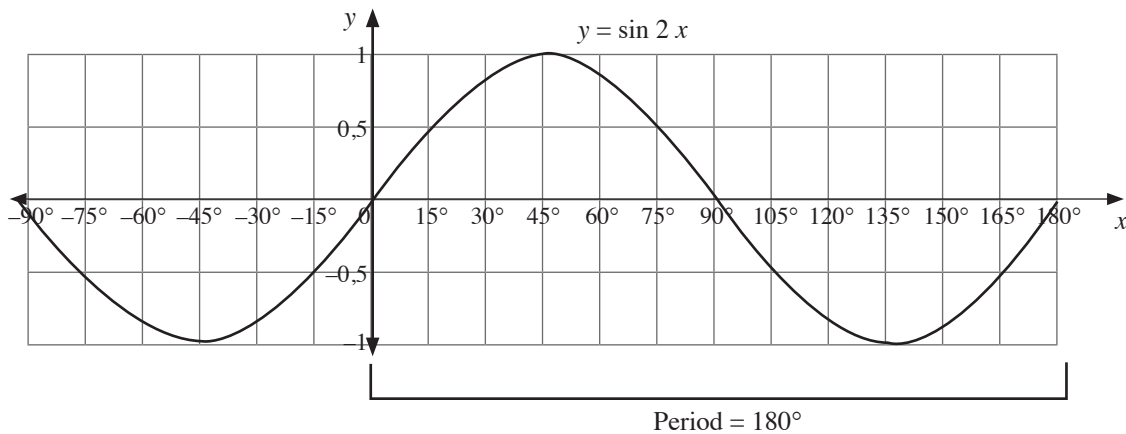

b) For $y = \cos 3x$, the period is $360^\circ \div 3 = 120^\circ$.

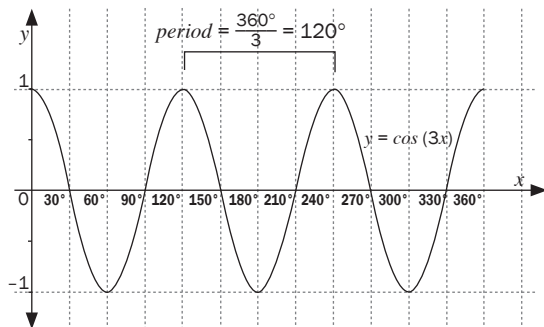

c) For $y = \tan \frac{1}{2}x$, the period $= 180^\circ \times 2 = 360^\circ$

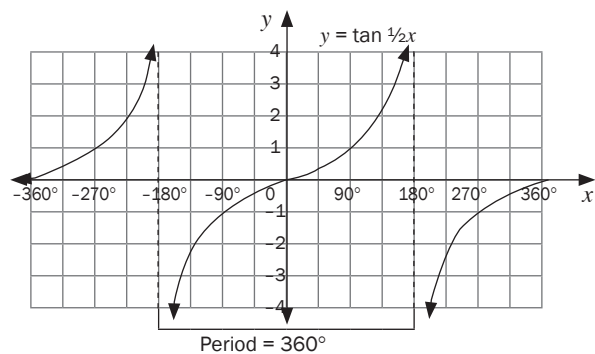

Conclusion

- The **period** of the graph is the number of degrees it takes to complete one wavelength.
- The value of b , affects the period of the graph
- For $y = \sin bx$ and $y = \cos bx$, the period = $\frac{360^\circ}{b}$
- For $y = \tan bx$, the period = $\frac{180^\circ}{b}$

5.5 The effect of p on the shape of the graph: horizontal shift

Consider the graphs of the form $y = \sin(x + p)$, $y = \cos(x + p)$ and $y = \tan(x + p)$.

e.g. 7

- Draw the following graphs on the same set of axes and for $x \in [-180^\circ, 180^\circ]$:
 - $y = \sin x$ and $y = \sin(x + 60^\circ)$
 - $y = \cos x$ and $y = \cos(x - 45^\circ)$
 - $y = \tan x$ and $y = \tan(x + 45^\circ)$

Solutions

- a) $y = \sin x$; $y = \sin(x + 60^\circ)$

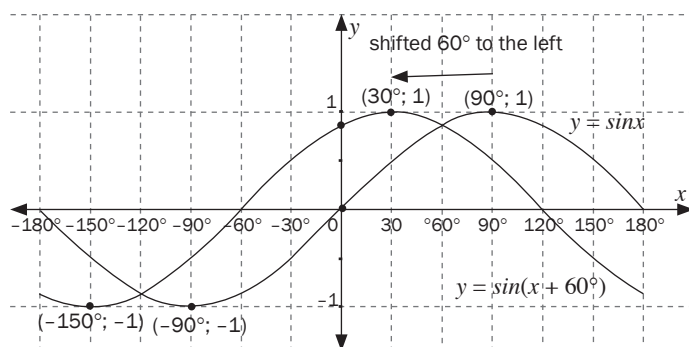

The graph of $y = \sin x$ has shifted 60 to the left to form $y = \sin(x + 60^\circ)$

- $y = \cos x$, $y = \cos(x - 45)$

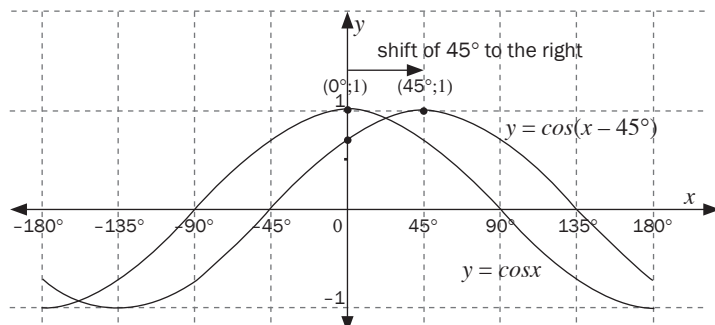

The graph of $y = \cos x$ has shifted 45 to the right to form $y = \cos(x - 45)$.

c) $y = \tan x$ and $y = \tan(x + 45^\circ)$

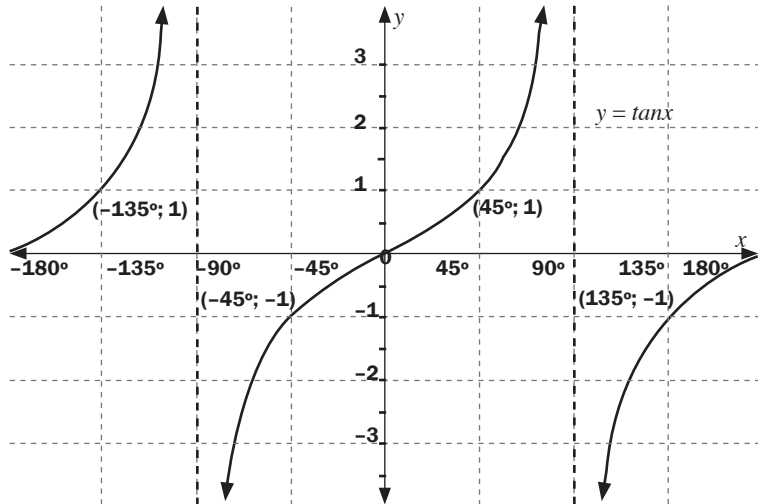

The graph of $y = \tan x$ has shifted 45 to the left to form $y = \tan(x + 45^\circ)$. The asymptotes have also shifted 45 to the left.

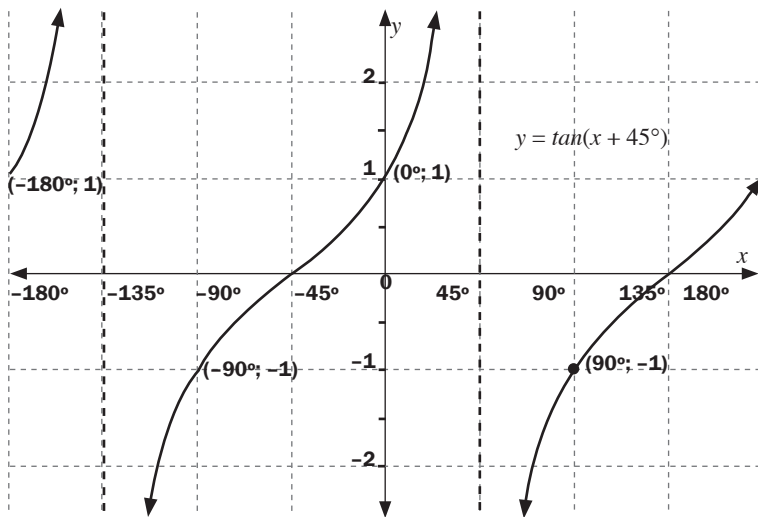

Conclusion

For graphs of the form $y = \sin(x + p)$, $y = \cos(x + p)$ and $y = \tan(x + p)$,

p affects the horizontal shift of the graph.

- If $p > 0$ (positive), the graph moves p degrees to the left.
- If $p < 0$ (negative), the graph moves p degrees to the right.
- In all graphs the x -intercepts, y -intercepts, maximum and minimum points must be indicated on the graph. If the value of b changes, the x -intercepts, y -intercepts, maximum and minimum points also change. In order to ensure that these points are always indicated, use the following x -values for plotting the graph:

Equation	$b=1$	$b=2$	$b=3$	$b=1/2$
$y = \sin bx$ or $y = \cos bx$	From 0° , use intervals of 90° Interval = $\frac{90^\circ}{b}$ Period = $\frac{360^\circ}{b}$	From 0° , use intervals of 45° Interval = $\frac{90^\circ}{b}$ Period = $\frac{360^\circ}{b}$	From 0° , use intervals of 30° Interval = $\frac{90^\circ}{b}$ Period = $\frac{360^\circ}{b}$	From 0° , use intervals of 180° Interval = $\frac{90^\circ}{b}$ Period = $\frac{360^\circ}{b}$
$y = \tan bx$	From 0° , use intervals of 45° Interval = $\frac{45^\circ}{b}$ Period = $\frac{180^\circ}{b}$	From 0° , use intervals of $22,5^\circ$ Interval = $\frac{45^\circ}{b}$ Period = $\frac{180^\circ}{b}$	From 0° , use intervals of 15° Interval = $\frac{45^\circ}{b}$ Period = $\frac{180^\circ}{b}$	From 0° , use intervals of 90° Interval = $\frac{45^\circ}{b}$ Period = $\frac{180^\circ}{b}$
$y = \sin(x+p)$ or $y = \cos(x+p)$	From 0° , use intervals of $(90^\circ - p^\circ)$. with $p > 0$ The intervals for $y = \sin(x - 30)$ and $y = \sin(x + 30)$ will be the same. The intervals will be $90 - 30 = 60$.			
$y = \tan(x+p)$	From 0° , use intervals of $(45^\circ - p^\circ)$. with $p > 0$ The intervals for $y = \tan(x - 30)$ and $y = \tan(x + 30)$ will be the same. The intervals will be $45 - 30 = 15$.			



Activity 2

1. Given $f(x) = 2\cos x$ and $g(x) = \sin(x + 30^\circ)$
 - a) Sketch the graphs of f and g on the same set of axes for $x \in [-150^\circ; 180^\circ]$
Clearly show all intercepts with the axes and the coordinates of turning points. (7)

Use your graph to answer the following questions:

 - b) Write down the period of f . (1)
 - c) For which values of x is $f(x) = g(x)$? (2)
 - d) For which values of x is $f(x) > 0$? (2)
 - e) For which values of x is $g(x)$ increasing? (2)
 - f) Determine one value of x for which $f(x) - g(x) = 1,5$. (1)
 - g) If the curve of f is moved down one unit, write down the new equation of f . (2)
 - h) If the curve of g is moved 45° to the left, write down the new equation of g . (2)
2. Sketch below are the graphs of $g(x) = a\sin(x+p)$ and $f(x) = b\cos qx$ for $x \in [0^\circ; 180^\circ]$

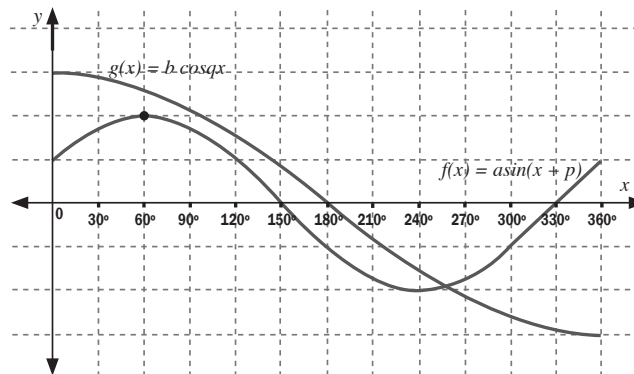

- a) Determine the numerical values of a , p , b and q . (5)
- b) If the graph of $g(x)$ is shifted two units down:
 - 1) Write down the amplitude of the new graph (1)
 - 2) Write down the equation of the new graph (2)
- c) If the graph of $f(x)$ is shifted 60 to the left, write down two possible equations of the new graph. (2)

[29]

Solutions

1. a) ✓✓✓ for $g(x) = 2 \cos x$ and ✓✓✓✓ for $f(x) = \sin(x + 30^\circ)$

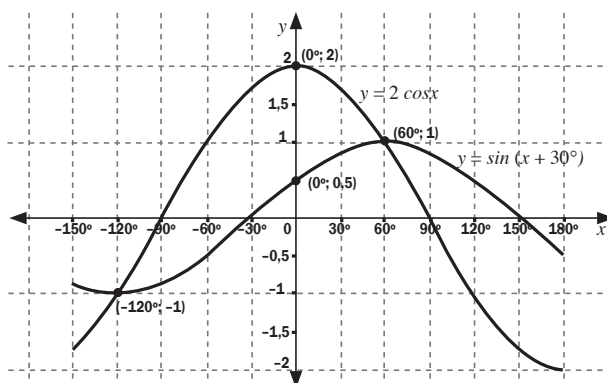

(7)

- b) period = 360° ✓ (1)
- c) $x = -120^\circ$ or 60° ✓✓ (2)
- d) for $f(x) > 0$; $x \in (-90^\circ; 90^\circ)$ ✓✓ (2)
- e) $g(x)$ increasing when $x \in (-120^\circ; 60^\circ)$ ✓✓ (2)
- f) $x = 0^\circ$ ✓ (1)
- g) New $f(x) = 2 \cos x - 1$ ✓✓ (2)
- h) Original equation: $g(x) = \sin(x + 30^\circ)$, with 45° shift to the left:
 $g(x) = \sin(x + 30^\circ + 45^\circ)$ so $g(x) = \sin(x + 75^\circ)$ ✓✓ (2)

2. a) $a = 2$ (amplitude of the $f(x)$) ✓
 $f(x) = 2\sin(x+p)$... Substitute 60°
 $\therefore 2 = 2\sin(60^\circ + p)$ ✓
 $\div 2 \therefore 1 = \sin(60^\circ + p)$
 Pressing shift $\sin^{-1}(1) = 90^\circ$
 $\therefore 60^\circ + p = 90^\circ \therefore p = 30^\circ$ ✓ $\therefore f(x) = 2\sin(x + 30^\circ)$ ✓
 $b = 3$ (amplitude of the $g(x)$)
 period = 720
 $720^\circ = \frac{360^\circ}{q} \therefore q = \frac{1}{2} \therefore g(x) = 3 \cos \frac{1}{2} x$ ✓ (5)

- b) (1) Amplitude = 3 (shift up or down has no effect on the amplitude) ✓ (1)
- (2) $g(x) = 3 \cos \frac{1}{2} x - 2$ ✓✓ (2)
- c) $f(x) = 2\sin(x + 90^\circ) = 2 \cos x$ ✓✓ (2)

[29]

What you need to be able to do

- Recognise the basic shapes of the graphs associated with their equations.
- Sketch functions and show the effect of different parameters a , p and q .
- Draw each graph using the critical points: intercepts with the axes and turning points, where applicable
- Show any asymptotes and include any other points you might need.
- Determine the features of graphs including
 - domain and range of functions
 - turning points
 - asymptotes
 - intercepts with axes
- Find the equation from the graph.
- Sketch trig functions, any shifts and changes in amplitude and period.

In Unit 10, we will discuss the solutions to trigonometric equations. You will be shown how to determine the solution of $2\cos x = \sin(x+30)$ algebraically. In this question the solutions can be read off the graphs.



Finance, growth and decay

6.1 Revision: Simple and compound interest



In all calculations, round off your final answer only.

Financial terms

- **Interest** is a fee paid for the use of borrowed money, or money earned on money saved. It is calculated as a percentage of the money borrowed or lent.
- **Simple interest** is the interest on an initial (principal) sum of money. Each year you receive or you are charged the same amount of interest.



Simple interest of 6% p.a. (per year) on R100 means that if you borrow R100 for a year, you owe that R100 and another R6 back. So you owe R106.

If you borrow R100 for 2 years, you will owe $R100 + R6 + R6 = R112$.

Micro-lenders and **Hire Purchase** agreements often work on simple interest at a monthly or at a yearly interest rate.

Percentage increase or decrease in populations, number of learners etc., can also be calculated using simple interest formula.

- **Compound interest** is also interest on a principal amount P . For each year, the previous year's final amount becomes the new principal amount. So the interest is calculated on the principal and the interest from the previous year.

Compound interest of 6% p.a. (per year) on R100 means that if you borrow R100 for 2 years, you owe $R100 + R6 = R106$ in the first year.

In the second year, you owe $R106 + 6\%$ of R106.

$R106 + (6\% \times R106) = R106 + R6,36 = R112,36$

Here are the formulae for simple and compound interest.

Simple interest: $A = P(1 + ni)$

where P is the principal (original sum of money invested or borrowed)

i is the interest rate

n is the number of years

A is the final amount

Compound interest: $A = P(1 + i)^n$

where P is the principal (original sum of money invested or borrowed)

i is the interest rate

n is the number of years

A is the final amount

e.g. 2

If you borrow R300 at 9% p.a **simple interest**, how much will you owe after 7 years?

Solution

$$A = ? \quad P = R300 \quad i = 9\% = \frac{9}{100} = 0,09 \quad n = 7 \text{ years}$$

$$A = P(1 + ni)$$

$$A = 300(1 + 7 \times 0,09) = 489$$

After 9 years you will owe R489.

- Write down what is given.
- Decide what you need to find.
- Solve for that variable.

If you borrow R300 at 9% p.a **compound interest**, how much will you owe after 7 years?

$$A = ? \quad P = 300 \quad i = 9\% = \frac{9}{100} = 0,09 \quad n = 7 \text{ years}$$

$$A = P(1 + i)^n$$

$$A = 300(1 + 0,09)^7$$

$$A = 300(1,09)^7$$

$$A = 548,411736\dots$$

$A \approx R548,41$ to the nearest cent.

Which is the better option?

$$R548,41 - R489 = R59,41$$

So compound interest is R59,41 more than simple interest after 7 years.

e.g. 3

1. You invest R1 570 at 11% p.a. compounded monthly.

a) How much will you receive after 7 years?

b) How much interest have you earned after 7 years?

Solutions

1. a) $A = P(1 + i)^n$

$$A = ? \quad P = R1\ 570 \quad n = 7 \text{ years} \times 12 \text{ months} = 84 \text{ time periods}$$

$$i = 11\% \div 12 \text{ months} = \frac{0,11}{12}$$

$$A = 1570 \left(\frac{1 + 0,11}{12} \right)^{7 \times 12}$$

$$A = 3\ 378,959672\dots$$

You will receive R3 378,96 (to the nearest cent) after 7 years.

b) You have earned $R3\ 378,96 - R1\ 570 = R1\ 808,96$ interest

Compounded monthly means the interest is calculated at the end of every month. So convert years to months.

11% per annum compounded monthly, so we divide the interest rate by 12 months.



Interest per annum compounded:

monthly $\rightarrow \frac{i}{12}$ n years \times 12 months

quarterly $\rightarrow \frac{i}{4}$ n years \times 4 quarters in the year

semi-annually or half-yearly, (every 6 months) $\rightarrow \frac{i}{2}$ n years \times 2



Activity 1

- 6.1.1** You invest R1 700 at an interest rate of 10% compounded quarterly. Calculate how much your investment is worth after 6 years. (3)
- 6.1.2** R25 000 is invested into a savings account. Calculate the value of the investment of the savings after 5 years if interest rates are:
- 11% compounded monthly
 - 11% compounded semi-annually
- (5)
[8]

Solutions

6.1.1 $A = ?$ $P = \text{R}1\,700$ $n = 6 \text{ years} \times 4 = 24$
 $i = 10\%$ compounded quarterly
 so divide by 4 $i = \frac{0,10}{4} \checkmark$
 $A = P(1 + i)^n$
 $A = 1\,700 \left(1 + \frac{0,10}{4}\right)^{24} \checkmark$
 $= \text{R}3\,074,83$ (to nearest cent) \checkmark (3)

6.1.2 a) $A = \text{R}25\,000$ $i = \frac{0,11}{12} \checkmark$ $n = 5 \times 12$
 $A = 25\,000 \left(1 + \frac{0,11}{12}\right)^{5 \times 12} \checkmark$
 $= \text{R}43\,222,89 \checkmark$

b) $A = \text{R}25\,000$ $i = \frac{0,11}{2}$ $n = 5 \times 2$
 $A = 25\,000 \left(1 + \frac{0,11}{2}\right)^{5 \times 2} \checkmark$
 $= \text{R}42\,703,61 \checkmark$ (5)
 [8]

6.2 Calculating the value of P , i and n

We can also use the formulae for compound and simple interest to calculate the principal P , the rate of interest i , or the time period n .

e.g. 4

- How much must John invest now so that after 5 years at 8% simple interest, he will have R4 200?

Solution

$$1. \quad A = \text{R}4\,200 \quad n = 5 \quad i = 8\% \quad P = ?$$

$$A = P(1 + n \cdot i)$$

$$4\,200 = P(1 + 5(0,08))$$

$$4\,200 = P(1,4)$$

$$P = \frac{4\,200}{1,4} = 3\,000$$

\therefore John must invest R3 000.

e.g. 5 (finding i)

A population increases from 12 000 to 214 000 in 10 years. At what annual (compound) rate does the population grow? (Give your answer correct to one decimal place.)

Solution

$$A = 214\,000 \quad P = 12\,000 \quad n = 10 \quad i = ?$$

$$A = P(1 + i)^n$$

$$214\,000 = 12\,000(1 + i)^{10}$$

$$\frac{214\,000}{12\,000} = (1 + i)^{10}$$

$${}^{10}\sqrt{\frac{214\,000}{12\,000}} = 1 + i$$

$$1,333899939... - 1 = i$$

$$0,333899939... = i$$

$$\therefore i = 33,389..%$$

The population grew at an annual (compound) rate of 33,4% (correct to one decimal place).

e.g. 6 (finding n)

Ms Gumede puts R3 500 into a savings account which pays 7,5% p.a. compound interest. After some years, her account is worth R4 044,69.

For how long did she invest the money?

Solution

$$A = \text{R}4\,044,69 \quad P = \text{R}3\,500 \quad n = ? \quad i = 7,5\% \text{ p.a.} = 0,075$$

$$A = P(1 + i)^n$$

$$4\,044,69 = 3\,500(1 + 0,075)^n$$

$$4\,044,69 = 3\,500(1,075)^n$$

$$\frac{4044,69}{3500} = (1,075)^n$$

$$1,155625714 = (1,075)^n$$

$$n = \log_{1,075} 1,155625714$$

$$n = 2,000008543$$

$$n = 2 \text{ years}$$

So Ms Gumede invested the money for 2 years.

- Substitute for A , P and i
- Simplify
- Divide by 3500
- Write in logarithmic form
- Use the log keys on the calculator
- Round off the answer to the nearest year





Activity 2

- Mary borrowed a certain sum of money from a bank at a compound interest rate of 15% calculated quarterly. After 3 years she now owes R7 000. How much did she borrow? (3)
- R1 570 is invested at 12% p.a. compound interest. After how many years will the investment be worth R23 000? (4)
- R2 000 was invested in a fund paying interest compounded monthly. After 18 months the value of the fund was R2 860, 00. Calculate the interest rate. (4)

[11]

Solutions

1. $A = R7000$

$$i = \frac{0,15}{4} \checkmark$$

$$n = 3 \times 4$$

$$P = ?$$

$$7000 = P \left(1 + \frac{0,15}{4} \right)^{3 \times 4} \checkmark$$

$$7000 = P(1,555454331) \dots\dots\dots \text{Divide both sides by } 1,555454331$$

$$P = R4500,29 \checkmark$$

(3)

2. $A = P(1 + i)^n$

substitute for A, P and i

$$23\,000 = 1\,570(1 + 0,12)^n \checkmark \checkmark$$

simplify and divide

$$\frac{23000}{1570} = (1,12)^n$$

keep the number on your calculator without rounding

$$14,6496\dots = (1,12)^n$$

use log laws

$$n = \log_{1,12} 14,6496\dots \checkmark$$

Use the log keys on your calculator.

$$n = 23,69 \text{ years}$$

 $n \approx 24$ years to the nearest year \checkmark (4)

3. $A = 2860$ $P = 2000$ $i = ?$ $n = 18$

$$A = P(1 + i)^n$$

$$2000 \left(1 + \frac{i}{12} \right)^{18} = 2860 \checkmark$$

$$\left(1 + \frac{i}{12} \right)^{18} = \frac{2860}{2000} \checkmark$$

$$1 + \frac{i}{12} = \sqrt[18]{1,43}$$

$$\frac{i}{12} = 0,020069541$$

$$i = 0,020069541\dots \checkmark$$

$$i = 0,2408344924 \times 100$$

$$i = 24,08\% \checkmark$$

(4)

[11]

6.3 Simple and compound decay formulae

Decay or depreciation is when a quantity decreases by a percentage of the amount present. For example, your assets (house, car) and machinery lose value through age and use.

Ways of calculating depreciation.

Simple decay or depreciation: $A = P(1 - ni)$

This is also called **straight line depreciation** because it can be represented with a straight line graph.

e.g. 7

A car worth R120 000 depreciates at a rate of 12% (simple interest) p.a. How much will the car be worth after 5 years?

Solution:

$$A = P(1 - ni) \quad A = ? \quad P = 120\,000 \quad i = 12\% = 0,12 \quad n = 5 \text{ years}$$

$$A = 120\,000 (1 - 5 \times 0,12)$$

$$A = 48\,000$$

The car will be worth R48 000 after 5 years.

Compound decay or depreciation: $A = P(1 - i)^n$

This is also called depreciation on a reducing balance because the interest is calculated on the amount left over as it decreases. The amount left over is 'the reducing balance'.

e.g. 8

A car worth R120 000 depreciates at a rate of 12% p.a. (on a reducing balance).

How much will the car be worth after 5 years?

Solution

$$A = P(1 - i)^n \quad A = ? \quad P = 120\,000 \quad i = 12\% = 0,12 \quad n = 5 \text{ years}$$

$$A = 120\,000 (1 - 0,12)^5$$

$$A = 63\,327,83002\dots$$

$$A = R63\,327,83 \text{ (to the nearest cent)}$$

***Compare this with simple depreciation:

The car's value is $R63\,327,83 - R48\,000 = R15\,327,83$ less on simple decay than on compound decay.



Activity 3

The value of a piece of machinery depreciates from R10 000 to R 5 000 in 4 years. What is the rate of depreciation, correct to two decimal places, if calculated on the:

- a) Straight line method (i.e. simple depreciation) (3)
 b) Reducing balance (i.e. compound depreciation) (3)
[6]

Solutions

a) $A = 5\ 000$ $P = 10\ 000$ $n = 4$

$i = ?$ Note: A is less than P

Straight line method:

$$A = P(1 - ni)$$

$$5\ 000 = 10\ 000(1 - 4i) \checkmark$$

$$\frac{5000}{10000} = (1 - 4i) \checkmark$$

$$0,5 - 1 = -4i$$

$$\frac{-0,5}{-4} = i$$

$$0,125 = i$$

$$i = 12,5\% \checkmark$$

(3)

b) Reducing balance:

$$A = P(1 - i)^n$$

$$5\ 000 = 10\ 000(1 - i)^4 \checkmark$$

$$\frac{5000}{10000} = (1 - i)^4 \checkmark$$

$$0,5 = (1 - i)^4$$

$$\sqrt[4]{0,5} = 1 - i$$

$$i = 1 - 0,8408\dots$$

$$i = 0,1591035\dots$$

$$i = 15,9\% \checkmark$$

(3)

[6]

6.4 Nominal and effective interest rates

1. A **nominal interest rate** is the **quoted interest rate**.
2. An **effective interest rate** is the actual interest rate received.
If you are quoted a **nominal** interest rate of 8% p.a., the resulting **effective** rate will be different depending on if it is worked out annually, monthly or semi-annually
3. We use the following formula to calculate the effective interest rate from the nominal interest rate or vice versa:

$$1 + i^{\text{effective}} = \left(1 + \frac{i^{\text{nominal}}}{k}\right)^k$$

If k is the number of times per year the interest is calculated.

e.g. 9

1. You borrow R500 at 8% p.a. compounded for one year.
At the end of the year you owe $500(1 + 0,08)^1 = \text{R } 540$
2. You borrow R500 at 8% p.a. compounded monthly for one year
At the end of the year you owe $500 \left(1 + \frac{0,08}{12}\right)^{1 \times 12} = \text{R } 541,50$
So effectively, you are charged R41,50 interest on R500.
Your interest rate is actually $\frac{\text{R}41,50}{\text{R}500} \times \frac{100}{1} = 8,3\%$.
So the effective interest rate is 8,3% p.a. but the nominal interest rate is 8% p.a.
3. What is the effective interest rate if 7,5% p.a. is calculated monthly?

Solution

$$1 + i^{\text{effective}} = \left(1 + \frac{0,075}{12}\right)^{12}$$

$$1 + i^{\text{effective}} = 1,07763$$

$$i^{\text{eff}} = 0,07763$$

$$\therefore i^{\text{eff}} = 7,76\%$$



Activity 4

1. Khosi wants to invest R5 000 for 3 years. Which is the better investment for her if the interest is 10,5% p.a compounded quarterly or 10,5% p.a. compounded monthly? (7)
 2. Convert a nominal interest rate of 9% per annum compounded semi-annually to the effective annual interest rate. (2)
- [9]**

Solutions

1.

First option: $A = ?$ $P = R5\ 000$ $i = \frac{0,105}{4} \checkmark$ $n = 3 \times 4$

$$A = P(1 + i)^n$$

$$A = 5\ 000 \left(1 + \frac{0,105}{4}\right)^{3 \times 4} \checkmark \quad \text{Use a calculator to work out the whole answer.}$$

$$A = R6823,51 \checkmark$$

Second option: $A = ?$ $P = R5\ 000$ $i = \frac{0,105}{12} \checkmark$ $n = 3 \times 12$

$$A = P(1 + i)^n$$

$$A = 5000 \left(1 + \frac{0,105}{12}\right)^{3 \times 12} \checkmark \quad \text{Use a calculator to work out the whole answer.}$$

$$A = R6\ 841,92 \checkmark$$

\therefore 10,5% compounded monthly gives Khosi a better interest on her investment. \checkmark (7)

2. $1 + i^{\text{effective}} = \left(1 + \frac{i^{\text{nominal}}}{k}\right)^k$ if k is the number of times per year the interest is calculated.

$$1 + i = \left(1 + \frac{0,09}{2}\right)^2 \checkmark$$

$$1 + i = 1,092025 \dots$$

$$i = 0,092025$$

\therefore 9,20% is the effective annual interest rate. \checkmark (2)

[9]

6.5 Investments with time and interest rate changes

Calculations of more than one interest, deposits and withdrawals are best done using timeline.

e.g. 10

Thabo invested R 1 000 in a bank for 10 years. The interest rate was 6,5% compounded quarterly for the first 3 years. For the next 5 years, the interest was calculated at 7,2% compounded monthly and for the remainder of the investment, the interest was at 7,8% compounded semi-annually.

How much money would Thabo get at the end of the investment?

Solution

First draw a timeline so that you understand the question.

Over 10 years, the interest rates are different over different time periods.

R1000

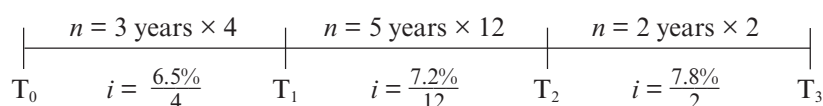

This can all be worked out in one calculation or you can do separate calculations. Remember not to round off answers until the end so that you can have accurate answers.

METHOD 1

$$A = 1000 \left(1 + \frac{0.065}{4}\right)^{3 \times 4} \left(1 + \frac{0.072}{12}\right)^{5 \times 12} \left(1 + \frac{0.078}{2}\right)^{2 \times 2} \checkmark \checkmark \checkmark$$

$$= R2024,64 \checkmark$$

METHOD 2

$$\text{Time}_1: A = 1000 \left(1 + \frac{0.065}{4}\right)^{3 \times 4} = R1\,213,407579 \checkmark$$

This amount of R1 213,407579 becomes P for the next calculation

$$\text{Time}_2: A = 1213,407579 \left(1 + \frac{0.072}{12}\right)^{5 \times 12} = R1\,737,342911 \checkmark$$

This amount of R1 735,911122 becomes P for the next calculation

$$\text{Time}_3: A = 1\,737,342911 \left(1 + \frac{0.078}{2}\right)^{2 \times 2} = R2\,024,64 \checkmark$$

After 10 years Thabo will get R 2 024,64 (to the nearest cent) ✓

NOTE: Rounding off was done on the final answer only.

[8]



Activity 5

Mr. Sithole invests R50 000 in an account which offers 8% p.a. interest compounded quarterly for the first 18 months. The interest then changes to 6% p.a. compounded monthly. Two years after the money is invested, R10 000 is withdrawn. How much will be in the account after 4 years?

[5]

Solution

Draw a timeline. The total length of time is 4 years.

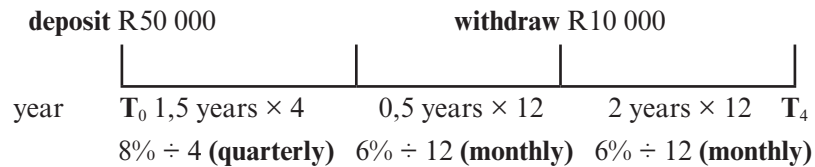

METHOD 1

DEPOSIT for the period of 4 years

$$A = 50000 \left(1 + \frac{0,08}{4}\right)^{1,5 \times 4} \left(1 + \frac{0,06}{12}\right)^{2,5 \times 12} - 10000 \left(1 + \frac{0,06}{12}\right)^{2 \times 12} \checkmark \checkmark \checkmark \checkmark$$

$$= R54\,124,66 \checkmark$$

OR

METHOD 2

First 18 months ($\frac{18}{12} = 1,5$ years):

$$P = R50\,000 \quad i = 8\% \text{ compounded quarterly} = \frac{0,08}{4} \quad n = 1,5 \text{ years} \times 4$$

$$A = 50000 \left(1 + \frac{0,08}{4}\right)^{1,5 \times 4} = R56\,308,12096 \checkmark \checkmark$$

Next 6 months (0,5 years):

$$P = R56\,308,12096 \quad i = 6\% \text{ compounded monthly} = \frac{0,06}{12} \quad n = 0,5 \times 12$$

$$A = 56308,12096 \left(1 + \frac{0,06}{12}\right)^{0,5 \times 12} = R58\,018,62143 \checkmark$$

R10 000 withdrawn, so R48 018,62143 remains as the new P value. ✓

Next 2 years

$$P = 48\,018,62134 \quad i = 6\% \text{ compounded monthly} = \frac{0,06}{12} \quad n = 2 \times 12$$

$$A = 48018,62134 \left(1 + \frac{0,06}{12}\right)^{2 \times 12} = R54\,124,66 \checkmark$$

[5]



Deposit of 50 000 with two different interest for the whole period minus the withdrawal with interest for the remaining period

6.6 Annuities

Annuities are number of equal payments made at regular intervals and subject to a rate of interest.

Types of annuities are: Future value annuities and Present value annuities.

6.6.1 Using the Future Value formula

- You can save money by putting away the same amount of money every month for use in the future. This can be done through an annuity fund, a retirement fund, a savings account, or a sinking fund.

Compound interest is earned on your savings, so you will receive, at some time in the future, the total of all your monthly installments, as well as interest calculated every month on an increasing monthly balance.

Future value formula

When you pay equal **monthly installments** in order to save money for the **future**, you can calculate using the **future value** formula.

$$F = \frac{x[(1+i)^n - 1]}{i}$$

where F is the total accumulated at the end of the time period

x is the monthly installment

i is the interest rate per annum

n is the number of installments/payments

This formula is provided on the **information sheet** in the final exam.

NOTE: The formula assumes that payments start at the *end of the first month*.



Sipho plans to save a fixed amount from his salary each month. He starts at the end of the month of his first salary. The bank offers an interest rate of 4,7% p.a. compounded monthly.

- Determine the amount he has to save every month if he wants to have R30 000 in his savings account at the end of 4 years.
- What is the total amount of interest he will receive after 4 years?

Solutions

- Sipho is saving for the future so use the Future Value formula.

$$F = R30\,000 \quad x \text{ is the monthly installment}$$

$$i = 4,7\% \text{ compounded monthly} = \frac{0,047}{12} \quad n = 4 \times 12 = 48 \text{ months}$$

$$F = x \frac{[(1+i)^n - 1]}{i}$$

$$30000 = \frac{x \left[\left(1 + \frac{0,047}{12} \right)^{48} - 1 \right]}{\frac{0,047}{12}}$$

$$30000 \times \frac{0,047}{12} = x \left[\left(1 + \frac{0,047}{12} \right)^{48} - 1 \right]$$

$$x = \frac{30000 \times \frac{0,047}{12}}{\left[\left(1 + \frac{0,047}{12} \right)^{48} - 1 \right]}$$

$$x = 569,30932\dots$$

- b) He must save R569,31 every month for 4 years.
 He will have paid $R569,31 \times 48 \text{ months} = R27\,326,88$
 So the total interest he will receive after 4 years is
 $R30\,000 - R27\,326,88 = R2\,673,12$

6.6.2 Sinking fund

e.g. 12

A printing company buys new printers at a cost of R3,2 million.

[Give all answers to the closest rand.]

- Calculate the book value of their printers after 5 years, if the depreciation is calculated at 16% p.a. on a reducing balance.
- Calculate the cost of replacing the printers at the end of 5 years, if the price of new printers increases by 8,5% p.a.
- How much more money would the company need if they sell the old printers at their book value and the money received is used towards the purchase of the new equipment?
- The company sets up a fund to make provision for replacing the old equipment at the end of 5 years. They deposit R240 000 at the end of the 1st year, R370 000 at the end of the 2nd year, R420 000 at the end of the 3rd year and R500 000 at the end of the 4th year. Determine the total amount of money accumulated in the fund at the end of 5 years if the interest paid on money in the fund is 11,5% p.a. compounded annually.
- How much additional money will they need to buy the replacement printers at the end of the replacement period?

Solutions:

- $P = R3\,200\,000$ $i = 16\% = 0,16$ $n = 5$
 $A = P(1 - i)^n$
 $A = 3\,200\,000(1 - 0,16)^5$
 $A = R1\,338\,278$
 Book value of R1 338 278
 - $P = R3\,200\,000$ $i = 8,5\% = 0,085$ $n = 5$
 $A = P(1 + i)^n$
 $A = 3\,200\,000(1 + 0,085)^5$
 $A = R4\,811\,701$
 Cost of replacing printers
 - $4\,811\,701 - 1\,338\,278 = R3\,473\,423$
 They need R3 473 423

d) timeline

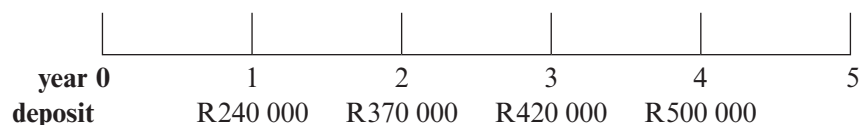
End of year 2:

$$P = R240\,000 \quad i = 11,5\% \text{ p.a.} = 0,115 \quad n = 1$$

$$A = P(1 + i)^n$$

$$A = 240\,000(1 + 0,115)^1 = R267\,600$$

$$R267\,600 + R370\,000 = R637\,600$$

End of year 3:

$$A = 637\,600(1 + 0,115)^1 = R710\,924$$

$$R710\,924 + R420\,000 = R1\,130\,924$$

End of year 4:

$$A = R1\,130\,924(1 + 0,115)^1 = R1\,260\,980,26$$

$$R1\,260\,980,26 + 500\,000 = R1\,760\,980,26$$

End of year 5:

$$A = 1\,760\,980,26(1 + 0,115)^1 = R1\,963\,492,99$$

After 5 years, they have R1963492,99 in the fund.

- e) $R4\,811\,701 - R1\,963\,492,99 - R1\,338\,278 = R1\,509\,930,01$ still needed for new printers.



Activity 6: Interpret a graph

- Ntsako invests R50 000 at 14% p.a. compounded annually. Liz saves R50 000 at 13,7% p.a. compounded monthly.
 - Who has the most money at the end of 20 years?
 - Calculate the difference in their investments after 20 years.

[6]

Solutions

1. a) Ntsako: $A = 50\,000(1 + 0,14)^{20} \checkmark = R687\,174,49 \checkmark$

Liz: $A = 50\,000 \left(1 + \frac{0,137}{12}\right)^{20 \times 12} = R762\,421,9984 = R762\,422,00 \checkmark \checkmark$

Liz has the most money. \checkmark

b) The difference is $R762\,422,00 - R687\,174,49 = R75\,247,51. \checkmark$

[6]

6.6.3 Using the Present Value formula

- You can borrow a large amount of money from the bank. This is called a **loan**. For example, there are student loans to pay for further studies, vehicle loans to buy a car and loans to buy a house.
- A **bond** or **mortgage** or a **home loan** is a loan used to buy a house or other property.
- The amount you must pay back is the total of the loan and the interest charged on it. You must pay back an equal amount each month called a **monthly installment**.

Each month, the interest is calculated on the amount you still owe. Because you are paying back the same amount monthly, the amount you owe is decreasing.

Here is a formula to work out your monthly installments. It is called the **Present Value Formula**. It is *present* because you receive the money *now* in the *present*. You start paying it back at the end of the first month of the loan.

$$P = \frac{x[1 - (1 + i)^{-n}]}{i}$$

where P is the Present value

x is the monthly installment

i is the interest rate p.a.

n is the number of time periods to repay the loan

This formula is provided on the **information sheet** in the final exam.

e.g. 13

A loan of R240 000 is repaid over 5 years with equal monthly payments (installments), starting one month after the loan was granted.

Notice: it is normal to start paying back a loan one month after it was granted.

- Calculate the monthly repayments if the interest on the loan is 9% p.a. compounded monthly.
- The client has financial difficulties and makes only 17 payments. Calculate the balance of the loan at the end of the 17th month.

The balance of a loan that must be paid at any particular time during the agreed loan time, can be calculated by using the present value formula for the remaining number of installments.



Solutions

1. a) P = R 240 000; x is the monthly installment

$$i = 9\% \text{ p.a.} \quad \text{monthly} = \frac{0,09}{12} \quad n = 5 \times 12 = 60$$

$$P = \frac{x[1 - (1 + i)^{-n}]}{i}$$

$$240000 = \frac{x \left[1 - \left(1 + \frac{0,09}{12} \right)^{-60} \right]}{\frac{0,09}{12}} \quad \checkmark \checkmark$$

$$x = \frac{240000 \left(\frac{0,09}{12} \right)}{\left[1 - \left(1 + \frac{0,09}{12} \right)^{-60} \right]} \quad \checkmark$$

$$x = R4\,982,0052... \approx R4\,982,01 \text{ (to the nearest cent)}$$

So the monthly installment is R4 982, 01 ✓

b) P = Balance of Loan x = R4 982,01 i = $\frac{0,09}{12}$ ✓

$$n = 60 - 17 = 43 \text{ monthly installments still to pay } \checkmark$$

$$P = \frac{x[1 - (1 + i)^{-n}]}{i}$$

$$P = \frac{4982,01 \left[1 - \left(1 + \frac{0,09}{12} \right)^{-43} \right]}{\frac{0,09}{12}} \quad \checkmark \checkmark$$

$$P = 182\,535,4693...$$

After 17 months he will still owe R 182 535,47 ✓

[9]



Activity 7

- In order to buy a car, Zack takes out a loan of R25 000 from the bank. The bank charges an annual interest rate of 11% compounded monthly. The installments start a month after he has received the money from the bank.
 - Calculate his monthly installments if he has to pay back the loan over a period of 5 years.
 - Calculate the outstanding balance of his loan after two years (immediately after the 24th instalment). (8)
 - Jill negotiates a loan of R300 000 with a bank which has to be repaid by means of monthly payments of R5 000 and a final payment which is less than R5 000. The repayments start one month after the granting of the loan. Interest is fixed at 18% per annum, compounded monthly.
 - Determine the number of payments required to settle the loan.
 - Calculate the balance outstanding after Jill has paid the last R5 000.
 - Calculate the value of the final payment made by Jill to settle the loan.
 - Calculate the total amount Jill repaid to the bank. (13)
- [21]**

Solutions

1. a) $P = R25\ 000$; $i = 11\%$ monthly $= \frac{0,11}{12}$ ✓ x is the monthly installment

$$n = 5 \times 12 = 60$$

$$P = \frac{x [1 - (1 + i)^{-n}]}{i}$$

$$25000 = \frac{x \left[1 - \left(1 + \frac{0,11}{12} \right)^{-60} \right]}{\frac{0,11}{12}} \quad \checkmark \checkmark$$

$$x = \frac{25000 \left(\frac{0,11}{12} \right)}{\left[1 - \left(1 + \frac{0,11}{12} \right)^{-60} \right]}$$

$$x = 543,5605768$$

His monthly installment will be R543,56 (to the nearest cent) ✓

- b) 5 years \times 12 months = 60 months. He still has to pay for 60 – 24 = 36 months.

$$P = ? \quad i = 11\% \text{ monthly} = \frac{0,11}{12} \quad x = R543,56 \quad n = 36 \quad \checkmark$$

$$P = \frac{x [1 - (1 + i)^{-n}]}{i}$$

$$P = \frac{543,56 \left[1 - \left(1 + \frac{0,11}{12} \right)^{-36} \right]}{\frac{0,11}{12}} \quad \checkmark \checkmark$$

$$P = 16602,8718\dots$$

The outstanding balance after two years will be R16 602,97 (to the nearest cent). ✓

(8)



$$2. \quad a) \quad P = 300\,000 \quad x = 5\,000 \quad i = \frac{0,18}{12} = 0,015 \checkmark \quad n = ?$$

$$P = \frac{x[1 - (1 + i)^{-n}]}{i} \checkmark$$

$$300\,000 = \frac{5000[1 - (1 + 0,015)^{-n}]}{0,015} \checkmark$$

$$300\,000 \times 0,015 = 5\,000 [1 - (1,015)^{-n}]$$

$$\frac{4500}{5000} - 1 = - (1,015)^{-n}$$

$$- (1,015)^{-n} = -0,1$$

$$-n = \frac{\log 0,1}{\log 1,015} \checkmark$$

$$n = 154,65$$

$$\therefore \text{Number of payments} = 155 \checkmark$$

$$b) \quad \text{Balance outstanding} = \frac{5\,000 \left[1 - \left(1 + \frac{0,18}{12} \right)^{-0,6541086} \right]}{\frac{0,18}{12}} \checkmark \checkmark \checkmark \checkmark$$

$$= R3230,50 \checkmark$$

$$c) \quad \text{Amount paid in last month}$$

$$= 3230,50 \left(1 + \frac{0,18}{12} \right) \checkmark$$

$$= R3278,96 \checkmark$$

$$d) \quad \text{Total repaid} = (154 \times 5000) + 3278,96 = R773278,96 \checkmark$$

(13)

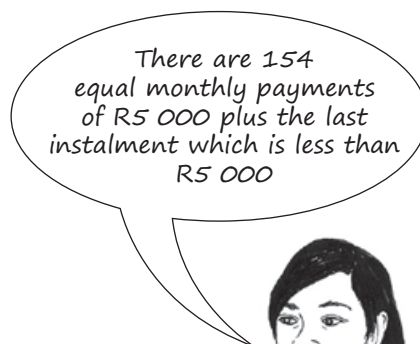
[21]



Activity 8

1. A farmer buys a tractor for R450 000.
 - a) How much will the tractor be worth in 5 years' time if its value depreciates at 9% per annum on a reducing balance? (3)
 - b) After 5 years, the tractor needs to be replaced. During this time, inflation remains constant at 7% per annum. Determine the cost of a new tractor after 5 years. (3)
 - c) He plans to sell this tractor at its book value and use the money towards a new tractor. Calculate how much money he will need to put into a Sinking Fund to buy a new tractor in 5 years' time. (1)
 - d) Calculate the value of the monthly payment into the sinking fund if the interest is 8,5% p.a. compounded monthly over the next 5 years. (4)
2. Timothy buys furniture to the value of R10 000. He borrows the money on 1 February 2010 from a financial institution that charges interest at a rate of 9,5% p.a. compounded monthly. Timothy agrees to pay monthly installments of R450. The agreement of the loan allows Timothy to start paying these equal monthly installments from 1 August 2010.
 - a) Calculate the total amount owing to the financial institution on 1 July 2010. (2)
 - b) How many months will it take to pay back the loan? (6)
 - c) What is the balance of the loan immediately after Timothy has made the 25th payment? (4)
3. Calculate how many years it will take for an investment to treble (becomes three times as big) if it is invested at 12% per annum compounded half-yearly. (5)

[28]

Solutions

1. a) Use compound depreciation with $P = R450\ 000$, $i = 0,09$,
 $n = 5$ years.
 $A = P(1 - i)^n$
 $A = 450\ 000(1 - 0,09)^5$ ✓✓
 $A = 280\ 814,4653$
 The tractor will be worth R 280 814,47 in 5 years' time. ✓
 (This is what its 'book value' or 'scrap value' will be in 5 years' time) (3)
- b) Use compound interest for inflation with $P = R450\ 000$, $i = 0,07$,
 $n = 5$ years.
 $A = P(1 + i)^n$
 $A = 450\ 000(1 + 0,07)^5$ ✓✓
 $A = 631\ 148,2788$
 A new tractor will cost R631 148,29 in 5 years' time. ✓ (3)

c) Cost of new tractor – book value of old tractor
 = R631 148,29 – R280 814,47
 = R350 333,82 in a Sinking Fund. ✓ (1)

d) Use the Future value formula and solve for x .
 $F = R350\,333,82x$ is the monthly installment
 $i = 8,5\%$ compounded monthly = $\frac{0,085}{12}$ $n = 5 \times 12 = 60$ months

$$F = \frac{x[(1+i)^n - 1]}{i}$$

$$350333,82 = \frac{x \left[\left(1 + \frac{0,085}{12}\right)^{60} - 1 \right]}{\frac{0,085}{12}} \quad \checkmark\checkmark\checkmark$$

$$x = \frac{350333,82 \left(\frac{0,085}{12}\right)}{\left[\left(1 + \frac{0,085}{12}\right)^{60} - 1\right]}$$

$$x = 4\,706,103568\dots$$

The monthly payment into the sinking fund over the next 5 years needs to be R4 706,10 (rounded off to the nearest cent) ✓ (4)

2. a) $A = 10000 \left(1 + \frac{0,095}{12}\right)^5$ ✓
 = R10 402,15 ✓ (2)

b) $10\,402,15 = \frac{450 \left[1 - \left(1 + \frac{0,095}{12}\right)^{-n}\right]}{\frac{0,095}{12}}$ ✓✓✓

$$0,183000787 = 1 - \left(\frac{1 + 0,095}{12}\right)^{-n}$$

$$\left(1 + \frac{0,095}{12}\right)^{-n} = 0,816999213 \quad \checkmark$$

$$\log \left(1 + \frac{0,095}{12}\right)^{-n} = \log 0,816999213 \quad \checkmark$$

$$-n \log \left(1 + \frac{0,095}{12}\right) = \log 0,816999213\dots$$

$$n = 25,63151282\dots$$

$$n = 25,63 \text{ months}$$

$$n = 26 \quad \checkmark$$

(6)

c) Balance outstanding after 25 months
 = 25, 6315128204... – 25
 = 0, 6315128204 ✓

$$\text{Balance outstanding} = \frac{450 \left[1 - \left(1 + \frac{0,095}{12}\right)^{-0,6315128204}\right]}{\frac{0,095}{12}} \quad \checkmark\checkmark$$

$$= R282, 36 \quad \checkmark \quad (4)$$

Multiply
10 402,15
by $\left(\frac{0,095}{12}\right)$ and then
divide by 450.

Write in log form to
calculate the value of n
(the number of
months to pay
back the loan).



3. Let x be the P, the investment in rand.

So the final amount A will be three times as much: $3x$ Rand.

$$i = 12\% \text{ compounded half-yearly (twice a year)} = \frac{0,12}{2} \checkmark$$

$$A = P(1 + i)^n$$

$$3x = x\left(1 + \frac{0,12}{2}\right)^{n \times 2} \checkmark \checkmark$$

$$\frac{3x}{x} = (1,06)^{2n}$$

$$3 = (1,06)^{2n} \quad \text{Use logs to find } n$$

$$2n = \log_{1,06} 3 \checkmark$$

$$2n = 18,85$$

$$n = 9,42708834\dots$$

It will take more than 9 years, so we say that the answer is 10 years. \checkmark

It will take 10 years for an investment to treble if interest of 12% is compounded half-yearly.

(5)

[28]

What you need to be able to do:

- Use the simple and compound growth formulae to solve problems.
- Use the simple and compound decay formulae to solve problems.
- Calculate the effect of different compounding periods on the effective interest rate when given the nominal interest rate and calculate the nominal interest rate when given the effective interest rate.
- Use the Present Value Formula for loans, etc.
- Use the Future Value Formula for annuities, savings, etc.
- To calculate the outstanding balance at any given time.
- To calculate the sinking fund.



Calculus

7.1 Average gradient

The gradient of a **straight line** can be calculated using $m = \frac{y_2 - y_1}{x_2 - x_1}$



Activity 1

- Determine the average gradient of the graph of $y = 5x^2 - 4$ between $x = -4$ and $x = -1$
 - Is the function increasing or decreasing between $x = -4$ and $x = -1$? (3)
- Determine the average gradient of the graph of $y = 5x^2 - 4$ between:
 - $x = 1$ and $x = 3$
 - $x = 2$ and $x = 3$
 - $x = 2,5$ and $x = 3$
 - $x = 2,99$ and $x = 3$ (8)
- Calculate the average gradient of the curve $f(x) = x(x + 3)$ between $x = 5$ and $x = 3$.
 - What can you deduce about the function f between $x = 5$ and $x = 3$? (3)



hint

Use the equation of the curve $y = 5x^2 - 4$ to calculate the y-values.

Use the $\frac{y_2 - y_1}{x_2 - x_1}$ formula to calculate the gradient.

(3)
[14]

Solutions

- At $x = -4$
 $y = 5(-4)^2 - 4 = 80 - 4 = 76 \checkmark$
 At $x = -1$
 $y = 5(-1)^2 - 4 = 5 - 4 = 1$
 $\frac{y_2 - y_1}{x_2 - x_1} = \frac{76 - 1}{-4 - (-1)} = \frac{75}{-3} = -25 \checkmark$ (2)
 - The function is decreasing between $x = -4$ and $x = -1$ because the gradient is negative. \checkmark (1)
- The points at $x = 1$ and $x = 3$ are (1; 1) and (3; 41) \checkmark
 $m = \frac{y_2 - y_1}{x_2 - x_1} = \frac{41 - 1}{3 - 1} = \frac{40}{2} = 20 \checkmark$ (2)
 - The points at $x = 2$ and $x = 3$ are (2; 16) and (3; 41) \checkmark
 $m = \frac{y_2 - y_1}{x_2 - x_1} = \frac{41 - 16}{3 - 2} = \frac{25}{1} = 25 \checkmark$ (2)
 - The points at $x = 2,5$ and $x = 3$ are (2,5; 27,25) and (3; 41) \checkmark
 $m = \frac{y_2 - y_1}{x_2 - x_1} = \frac{41 - 27,25}{3 - 2,5} = \frac{13,75}{0,5} = 27,5 \checkmark$ (2)
 - The points at $x = 2,99$ and $x = 3$ are (2,99; 40,7) and (3; 41) \checkmark
 $m = \frac{y_2 - y_1}{x_2 - x_1} = \frac{41 - 40,7}{3 - 2,99} = \frac{0,3}{0,01} = 30 \checkmark$ (2)
- The points are (5; 40) and (3; 18). \checkmark
 $m = \frac{y_2 - y_1}{x_2 - x_1} = \frac{18 - 40}{3 - 5} = \frac{-22}{-2} = 11 \checkmark$ (2)
 - The function is increasing between $x = 5$ and $x = 3$. \checkmark (1)

[14]

Can we calculate the gradient of a curve?

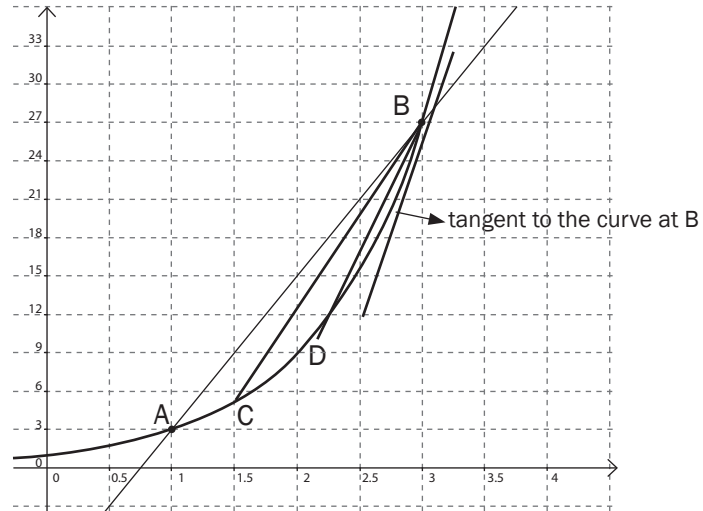

- The **average gradient** between two points on a curve is equal to the **gradient of the straight line** through the points. So the average gradient of curve AB is 12.
- As the two points are moved closer together, the average gradient approaches the gradient of the curve which is also the **gradient of the tangent** to the curve at that point. So the gradient of the curve AB at point B is 30.
- Remember that the tangent is a line that touches a curve at one point only.
- The average gradient tells us whether the graph is increasing or decreasing between those points.
- If the function is **decreasing** between two points, the average gradient will be **negative**.
- If the function is **increasing** between two points, the average gradient will be **positive**.

7.2 Average rate of change

The average rate of change between two points on a graph is the **average gradient** of the line joining the two points.

If the graph shows distance as a function of time, the average gradient

is $\frac{\text{change of distance}}{\text{change in time}}$

This is the **average speed** = $\frac{\Delta \text{distance}}{\Delta \text{time}}$

e.g. 1

1. The average rate of change between A and B shown in the graph

is $\frac{27-3}{3-1} = \frac{24}{2} = 12$.

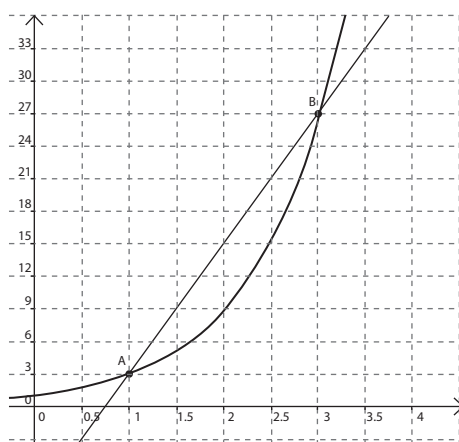

2. If the distance travelled (in metres) is given by the equation $s(t) = t^2$, where t is the time in seconds, then the average speed between $t = 3$ seconds and $t = 5$ seconds is $\frac{5^2 - 3^2}{5 - 3} = \frac{25 - 9}{2} = \frac{16}{2} = 8$ m/s.

7.3 The derivative of a function at a point

The rate of change of a function **at a point** is called a **derivative**.

The derivative of a function at a point gives

- the rate of change of the function at the point
- the slope (gradient) of the tangent to the function at the point

Definition of a derivative

The derivative of a function $y = f(x)$ is defined as $f'(x) = \lim_{h \rightarrow 0} \frac{f(x+h) - f(x)}{h}$

This formula is provided on the **information sheet** in the final exam.

NOTE: The notation we use for the derivative of $y = f(x)$ is

$f'(x)$ or y' or $\frac{dy}{dx}$ or $D_x[f(x)]$.

When we find the derivative of a function, we say we **differentiate** the function.

$f'(x)$ is the rate of change of f at x



7.3.1 The derivative from first principles (Definition)

To differentiate from first principles (definition) use the formula below

$$f'(x) = \lim_{h \rightarrow 0} \frac{f(x+h) - f(x)}{h}$$



Determine $f'(x)$ from first principles if $f(x) = -3x^2$

Solution

Method 1

$$\begin{aligned} f(x+h) &= -3(x+h)^2 \\ &= -3(x^2 + 2xh + h^2) \\ &= -3x^2 - 6xh - 3h^2 \text{ to get } f(x+h) \text{ we replace } x \text{ with } x+h \text{ and get} \\ &\quad -3(x+h)^2 \end{aligned}$$

Expand the brackets and Make sure you multiply the -3 with each term in the brackets

Substituting into $f'(x) = \lim_{h \rightarrow 0} \frac{f(x+h) - f(x)}{h}$ the definition of the derivative gives

$$\begin{aligned} f'(x) &= \lim_{h \rightarrow 0} \frac{-3x^2 - 6xh - 3h^2 - (-3x^2)}{h} \quad f(x) = -3x^2 \text{ so} \\ &= \lim_{h \rightarrow 0} \frac{-3x^2 - 6xh - 3h^2 + 3x^2}{h} \end{aligned}$$

Take out a common factor of h so you can cancel it with the h in the denominator.

As h goes to 0, $-6x - 3h$ goes to $-6x$.

$$\begin{aligned}
 &= \lim_{h \rightarrow 0} \frac{h(-6x - 3h)}{h} \\
 &= \lim_{h \rightarrow 0} (-6x - 3h) \\
 &= -6x
 \end{aligned}$$



Activity 2

- Determine $f'(x)$ from first principles if $f(x) = 5x^2 - 4x + 2$ (6)
 - Determine $f'(x)$ from first principles if $f(x) = \frac{2}{x}$ (6)
- [12]**

Solutions

$$\begin{aligned}
 1. \quad f(x+h) &= 5(x+h)^2 - 4(x+h) + 2 \\
 &= 5(x^2 + 2xh + h^2) - 4x - 4h + 2 \\
 &= 5x^2 + 10xh + 5h^2 - 4x - 4h + 2 \quad \checkmark
 \end{aligned}$$

$$\begin{aligned}
 f'(x) &= \lim_{h \rightarrow 0} \frac{f(x+h) - f(x)}{h} = \lim_{h \rightarrow 0} \frac{5x^2 + 10xh + 5h^2 - 4x - 4h + 2 - (5x^2 - 4x + 2)}{h} \quad \checkmark \\
 &= \lim_{h \rightarrow 0} \frac{10xh + 5h^2 - 4h}{h} \quad \checkmark \\
 &= \lim_{h \rightarrow 0} \frac{h(10x + 5h - 4)}{h} \quad \checkmark \\
 &= \lim_{h \rightarrow 0} (10x + 5h - 4) \quad \checkmark \\
 &= 10x - 4 \quad \checkmark
 \end{aligned}$$

(6)

$$2. \quad f(x+h) = \frac{2}{x+h}$$

$$\begin{aligned}
 f'(x) &= \lim_{h \rightarrow 0} \frac{f(x+h) - f(x)}{h} = \lim_{h \rightarrow 0} \frac{\frac{2}{x+h} - \frac{2}{x}}{h} \quad \checkmark \checkmark \\
 &= \lim_{h \rightarrow 0} \frac{\frac{2x}{x(x+h)} - \frac{2(x+h)}{x(x+h)}}{h} \quad \checkmark \\
 &= \lim_{h \rightarrow 0} \frac{\frac{2x - 2x - 2h}{x(x+h)}}{h} \\
 &= \lim_{h \rightarrow 0} \frac{\frac{-2h}{x(x+h)}}{h} \\
 &= \lim_{h \rightarrow 0} \frac{-2h}{x(x+h)} \times \frac{1}{h} \quad \checkmark \\
 &= \lim_{h \rightarrow 0} \frac{-2}{x(x+h)} \quad \checkmark \\
 &\simeq \frac{-2}{x(x)} = \frac{-2}{x^2} \quad \checkmark
 \end{aligned}$$

(6)

[12]

7.3.2 The rules of differentiation

You could find any derivative from first principles, but there are some quick rules to find the derivative. **Unless a question asks you to use the definition or to 'differentiate from first principles', it is easier to use the rules.**

You need to know and be able to use the following rules for differentiating:

Rules

1. If $f(x) = b$ then $f'(x) = 0$
where b is a constant
2. If $f(x) = x^n$ then $f'(x) = nx^{n-1}$
3. $\frac{d}{dx}[f(x) \pm g(x)] = \frac{d}{dx}[f(x)] \pm \frac{d}{dx}[g(x)]$
4. $\frac{d}{dx}[kf(x)] = k\frac{d}{dx}[f(x)]$

e.g. 3

If $h(x) = 12$, then $h'(x) = 0$
The derivative of a constant is always $= 0$.
If $k(x) = x^5$, then $k'(x) = 5x^4$
If $f(x) = x^5 + x^4$, then $\frac{d}{dx}f(x) = 5x^4 + 4x^3$
If $f(x) = 3x^5$ then
 $\frac{d}{dx}f(x) = 3 \times \frac{d}{dx}f(x) (x^5) = 3 \times 5x^4 = 15x^4$

Before you use differentiation you might need to simplify or change the format of the expressions:

1. **Expand brackets** e.g. expand $(3x + 2)(x - 5)$ to $3x^2 - 13x - 10$ because you have no rule for differentiating a product.
So you need separate terms before you can differentiate.

e.g. 4

Determine $f'(x)$ if $f(x) = (3x + 2)(x - 5)$

Solution

$$f(x) = 3x^2 - 13x - 10$$

$$\therefore f'(x) = 6x - 13$$

2. Rewrite terms which are square **roots**, cube roots or other roots as **exponentials** so that you can use the rule: if $f(x) = x^n$ then $f'(x) = nx^{n-1}$

e.g. 5

$$\sqrt{x} = x^{\frac{1}{2}} \text{ so } \frac{d}{dx} \sqrt{x} = \frac{1}{2}x^{-\frac{1}{2}}$$



Activity 3

- a) Evaluate $D_x[(x^3 - 3)^2]$ b) Find $f'(x)$ if $f(x) = \sqrt[3]{x}$
 c) Find $\frac{d}{dx} \sqrt[3]{x^5}$ d) Differentiate $f(x)$ if $f(x) = \sqrt{x^4}$ e) Find $f'(x)$ if $f(x) = \sqrt{16x^3}$

[11]

Solutions	
a) $D_x[(x^3 - 3)^2]$ $= D_x[x^6 - 6x^3 + 9] \checkmark$ $= 6x^5 - 18x^2 \checkmark \checkmark$	First multiply out Apply the rules of differentiation
b) $\sqrt[3]{x} = x^{\frac{1}{3}}$ so $f'(x) = \frac{1}{3} x^{-\frac{2}{3}} \checkmark \checkmark$	c) $\sqrt[3]{x^5} = x^{\frac{5}{3}}$ so $\frac{d}{dx} (\sqrt[3]{x^5}) = \frac{5}{3} x^{\frac{2}{3}} \checkmark \checkmark$
d) $\sqrt{x^4} = x^2 = x^2 \checkmark$ so $f'(x) = 2x^1 = 2x \checkmark$	e) $f(x) = \sqrt{16x^3} = 4(x^3)^{\frac{1}{2}} = 4x^{\frac{3}{2}} \checkmark$ So $f'(x) = \frac{3}{2} \cdot 4 \cdot x^{\frac{3}{2}-1} = 6x^{\frac{1}{2}} \checkmark$ You can write the answer as $6\sqrt{x}$ or as $6x^{\frac{1}{2}}$

[11]

Rewrite terms which are 'fractions' where x is part of the denominator, $\frac{1}{x^n}$ as x^{-n} so that you can use the rule: if $f(x) = x^n$ then $f'(x) = nx^{n-1}$



Find $f'(x)$ if $f(x) = \frac{3x^2}{4x^3}$

Solution

$$f(x) = \frac{3x^2}{4x^3} = \frac{3}{4}x^{-1}$$

$$\text{So } f'(x) = -\frac{3}{4}x^{-2} = -\frac{3}{4x^2}$$



Activity 4

1. Determine, using the rules of differentiation: $\frac{dy}{dx}$ if $y = \frac{\sqrt{x}}{2} - \frac{1}{6x^3}$ (3)

2. Evaluate $\frac{dy}{dx}$ if $y = \frac{4}{\sqrt{x}} - \frac{x^3}{9}$ (3)

3. Determine $D_x \left[\frac{6x+5}{3x^2} \right]$ (4)

[10]

Solutions

1. $y = \frac{\sqrt{x}}{2} - \frac{1}{6x^3}$

$$y = \frac{1}{2}x^{\frac{1}{2}} - \frac{1}{6}x^{-3} \checkmark$$

First rewrite the terms in the form kx^n

$$\frac{dy}{dx} = \frac{1}{4}x^{-\frac{1}{2}} + \frac{3}{6}x^{-4}$$

Use the rules of differentiation

$$\frac{dy}{dx} = \frac{1}{4}x^{-\frac{1}{2}} + \frac{1}{2}x^{-4}$$

Simplify

$$\frac{dy}{dx} = \frac{1}{4\sqrt{x}} + \frac{1}{2x^4} \checkmark \checkmark$$

Change back to surds and positive exponents (3)

2. $y = \frac{4}{\sqrt{x}} - \frac{x^3}{9}$

$$y = 4x^{-\frac{1}{2}} - \frac{1}{9}x^3 \checkmark$$

First rewrite the terms in the form kx^n

$$\frac{dy}{dx} = -\frac{1}{2} \cdot 4(x^{-\frac{1}{2}-1}) - 3 \cdot \frac{1}{9}x^2$$

Use the rules of differentiation

$$\frac{dy}{dx} = -2x^{-\frac{3}{2}} - \frac{1}{3}x^2 \checkmark \checkmark$$

Simplify (3)

Often, the question will ask you to leave the answer with positive exponents.

$$= -\frac{2}{x^{\frac{3}{2}}} - \frac{1}{3}x^2$$

3. $D_x \left[\frac{6x+5}{3x^2} \right] = D_x \left[\frac{6x}{3x^2} + \frac{5}{3x^2} \right] \checkmark$

$$= D_x \left[2x^{-1} + \frac{5}{3}x^{-2} \right] \checkmark$$

$$= -2x^{-2} - \frac{10}{3}x^{-3} \checkmark \checkmark$$

(4)
[10]

7.4 Uses of the derivative

The derivative has many uses.

It can be used to:

- find the gradient of the equation of a tangent line
- identify stationary points on a graph
- find a maximum or minimum value
- describe rates of change
- draw graphs of cubic functions.
- (A cubic function has the form $f(x) = ax^3 + bx^2 + cx + d$)

7.4.1 Finding the equation of a tangent line

The slope of the tangent line to the graph at a point is equal to the derivative of the function at that point. So, to find the equation of the tangent line to $f(x)$ at $x = a$, we must:

1. Find the derivative $f'(x)$
2. Work out the derivative at $x = a \rightarrow$ i.e calculate $f'(a)$ to get the gradient of the tangent line.
3. Calculate the y value at $x = a \rightarrow$ i.e calculate $f(a)$.
4. The tangent line is a straight line.
We can find the equation of a straight line using $y - y_1 = m(x - x_1)$ if we know the gradient m and a point $(x_1; y_1)$ on the line.



Find the equation of the tangent to the function $f(x) = x^3 + 2x + 4$ at the point where $x = 1$.

Solution

$$f'(x) = 3x^2 + 2$$

$$f'(1) = 3(1)^2 + 2 = 5$$

$$\text{so } m = 5$$

$$f(1) = 1 + 2 + 4 = 7$$

$$\text{Tangent line: } y - 7 = 5(x - 1)$$

$$y - 7 = 5x - 5$$

$$y = 5x + 2$$

So the equation of the tangent at $x = 1$ is $y = 5x + 2$

1. Take the derivative

2. Find the gradient of the tangent at $x = 1$ by evaluating the derivative at $x = 1$.

3. Calculate the y -value at $x = 1$

4. Use $y - y_1 = m(x - x_1)$ to give the equation of the tangent line

7.5 Drawing the graph of a cubic polynomial

A cubic polynomial is a function of the form $f(x) = ax^3 + bx^2 + cx + d$ and we can represent it with a graph. In order to draw the graph, we need to work out the characteristics of the graph.

- We can use the derivative to identify the slope of the graph at certain points.
- We also need to know how to solve equations in the third degree, so that we can work out the x - and y -intercepts of the graph.

7.5.1 Solving equations in the third degree:

$$ax^3 + bx^2 + cx + d = 0$$



Work through this example:

Factorise and solve for x : $x^3 - x^2 - 5x = 3$

Solutions

1. Get $ax^3 + bx^2 + cx + d = 0$ i.e. $x^3 - x^2 - 5x - 3 = 0$ (Standard form)

2. Use the **Factor and Remainder** theorem to find one factor.

Use trial and error.

This step can also be calculated on a calculator – see below.

The factor theorem states:

If $f(k) = 0$, then $x - k$ is a factor of $f(x)$

So if $f(x) = x^3 - x^2 - 5x - 3$, we want to find an x -value that makes $f(x) = 0$.

$f(x)$ has a constant value of -3 .

If this expression can be factorised, then at least one of its factors will use a factor of -3 in it.

The factors of -3 are -3 ; -1 ; 1 ; 3

By trial and error, test these factors to find which value of x gives $f(x) = 0$.

$$f(x) = x^3 - x^2 - 5x - 3$$

$$\text{If } x = -3, \text{ then } f(-3) = -27 - 9 + 15 - 3 = -24 \neq 0$$

$$\text{If } x = -1, \text{ then } f(-1) = -1 - 1 + 5 - 3 = 0$$

$\therefore x - (-1)$ is a factor of $f(x)$

$\therefore x + 1$ is a factor of $x^3 - x^2 - 5x - 3$.

We will use $x + 1$ to find the other factors.

3. Divide $x^3 - x^2 - 5x - 3$ by $x + 1$ to find the other factors.

You can use the algebraic method, long division or synthetic division at this point.

Method I: Using algebra

$$x^3 - x^2 - 5x - 3 = (x + 1)(x^2 + px - 3)$$

Check this: First terms give x^3 , last terms give -3 .

We don't know the middle terms, so we have used px in the second bracket.

To calculate the value of p :

The x^2 term in the expression has a coefficient of -1

So the x^2 part of the factorised expression must make $-x^2$

$$x(px) + 1(x^2) = px^2 + x^2$$

$$\therefore px^2 + x^2 = -x^2$$

$$px^2 = -2x^2$$

$$\therefore p = -2$$

$$\therefore x^3 - x^2 - 5x - 3 = (x + 1)(x^2 - 2x - 3)$$

$$x^3 - x^2 - 5x - 3 = (x + 1)(x^2 - 2x - 3)$$

Method II: Long division

[Divide, Multiply, Subtract, Bring down]

	$x^2 - 2x - 3$		
$x + 1$	$x^3 - x^2 - 5x - 3$		divide: $x^3 \div x$ answer x^2 on top
	$x^3 + x^2$		multiply: $x^2(x + 1)$
	$-2x^2 - 5x$		subtract & bring down
	$-2x^2 - 2x$		divide: $-2x^2 \div x$ answer $-2x$ on top
	$-3x - 3$		multiply: $-2x(x + 1)$
	$-3x - 3$		subtract & bring down
	0		divide: $-3x \div x$ answer -3 on top
			multiply: $-3(x + 1)$
			subtract

$$\therefore x^3 - x^2 - 5x - 3 = (x + 1)(x^2 - 2x - 3) = (x + 1)(x - 3)(x + 1)$$

Method III: Synthetic division

Write down the coefficients of the terms in the original equation, $x^3 - x^2 - 5x - 3$.

a) On the left place $x = -1$

$$-1 \quad | \quad 1 \quad -1 \quad -5 \quad -3$$

b) Write down the first coefficient (1) and multiply:

$$-1 \times 1 = -1$$

Put this under the 2nd coefficient (-1)

	1 st coeff	2 nd coeff	3 rd coeff	4 th coeff
(-1)	1	-1	-5	-3
		1		
			-1	

answer

d) Multiply -1 by $-3 = +3$

Put this under the 4th coefficient (-3)

Add the 4th column: $-3 + 3 = 0$

	1 st coeff	2 nd coeff	3 rd coeff	4 th coeff
(-1)	1	-1	-5	-3
		1	-1	+3
			-2	0

Add the second column: $-1 + -1 = -2$

	1 st coeff	2 nd coeff	3 rd coeff	4 th coeff
-1	1	-1	-5	-3
	1	-1		
		-2		

c) Multiply -1 by $-2 = +2$

Put this under the third coefficient (-5)

Add the third column: $-5 + 2 = -3$

	1 st coeff	2 nd coeff	3 rd coeff	4 th coeff
(-1)	1	-1	-5	-3
	1	-1	+2	
			-3	

1. You know you are correct when the final sum is 0. These numbers form the coefficients of the answer of the division:

	1 st coeff	2 nd coeff	3 rd coeff	4 th coeff
-1	1	-1	-5	-3
	1	-1	+2	+3
		-2	-3	0

$$1x^2 - 2x - 3$$

$$\therefore x^3 - x^2 - 5x - 3 = (x + 1)(x^2 - 2x - 3)$$

$$= (x + 1)(x - 3)(x + 1)$$

Now you have found the first factor $(x + 1)$ using one of the three methods.

4. Factorise the answer further by factorising the trinomial.

$$x^3 - x^2 - 5x - 3 = (x + 1)(x^2 - 2x - 3) = (x + 1)(x - 3)(x + 1)$$

5. Determine the three solutions.

$$\text{If } (x + 1)(x - 3)(x + 1) = 0,$$

$$\text{Then } (x + 1) = 0 \quad \text{or} \quad (x - 3) = 0 \quad \text{or} \quad (x + 1) = 0$$

$$x = -1 \quad \text{or} \quad x = 3 \quad \text{or} \quad x = -1$$

These are the x -intercepts of a cubic graph with the equation: $f(x) = x^3 - x^2 - 5x - 3$

7.5.2 Stationary points of a cubic function

- Stationary points on a graph are points where the **gradient of the graph is 0**. This is at points where the direction of the curve of the graph changes.

On a cubic function, the stationary points are at local **maximum** or **minimum turning point**. There are also situations where a **point of inflection** can also be a stationary point as indicated on figure 2 of the example below.

NOTE: A point of inflection is not always a stationary point.



The turning points are only *local* because the end points of the graphs are often greater than the local maximum or less than the local minimum.

figure 1

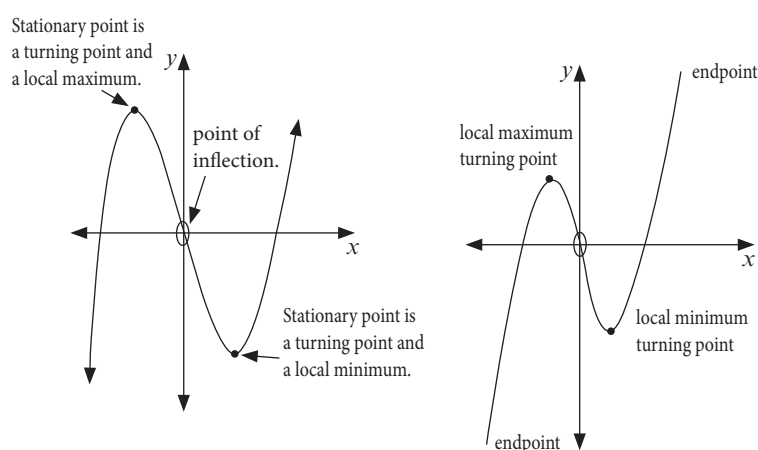
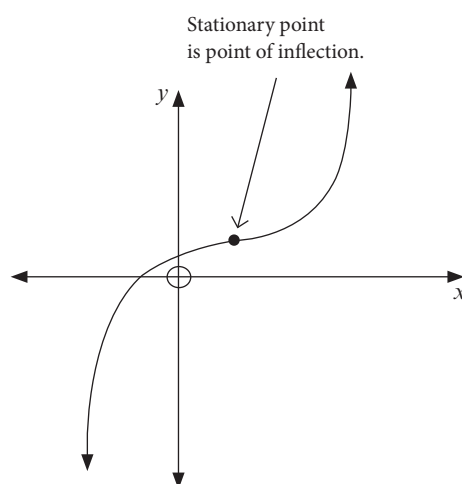

figure 2



The derivative $f'(x)$ gives us the slope of a graph.

So to find the coordinates of the turning points of a function $f(x)$, we solve $f'(x) = 0$.

To find the coordinates of the point of inflection, find the *derivative of the derivative*, $f''(x)$. This is called the second derivative. Solve for $f''(x) = 0$.

7.5.3 Drawing the graph of a cubic function

To draw a graph of a cubic function, follow these steps:

1. Find the **y-intercept** by finding $f(0)$. When $x = 0$, what is the value of y ?
2. Find the **x-intercepts** by finding x value(s) where $f(x) = 0$. Factorise $f(x)$ to be able to work out these values.

You need to learn the steps of drawing a cubic polynomial!

Identify one factor using the **factor theorem**.

The factor theorem: If $f(k) = 0$, then $x - k$ is a factor of $f(x)$.

3. Find the **stationary points or turning point** by solving $f'(x) = 0$.

NB: The three steps indicated above are very important. Sketch graph should have all the above points with correct identification of the shape explained below.

4. Identify the **end behavior** i.e. identify what happens to the graph for very large positive and negative values of x .

- If $a > 0$, then $f(x)$ is positive for very big values of x and negative for very big negative values of x .
- If $a < 0$, then $f(x)$ is negative for very big values of x and positive for very big negative values of x .

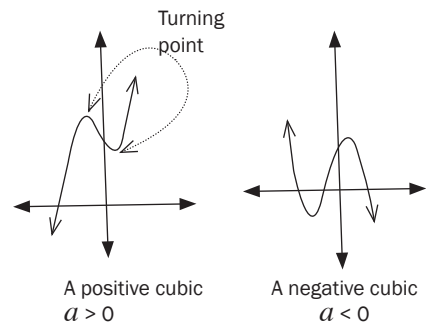

e.g. 10

Sketch the graph of $f(x) = x^3 - 4x^2 - 11x + 30$.

1. **y-intercept:** When $x = 0$, $f(0) = 30$ so y -intercept is at $(0; 30)$.
2. **x-intercepts:** Test some values of x (choose factors of 30)
 $f(1) = 16$ so $(x - 1)$ is not a factor. $f(-1) = 36$ so $(x + 1)$ is not a factor.
 $f(2) = 0$ so $(x - 2)$ is a factor.

Choose Method I, II or III above to continue. Here is the synthetic method. This method is very quick once you can use it accurately.

	1 st coeff	2 nd coeff	3 rd coeff	4 th coeff
2	1	-4	-11	30
	1	2	-4	-30
		-2	-15	0

$$\therefore x^3 - 4x^2 - 11x + 30 = (x - 2)(x^2 - 2x - 15)$$

$$\therefore x^3 - 4x^2 - 11x + 30 = (x - 2)(x - 5)(x + 3) \quad \text{Factorise the trinomial}$$

So when $y = 0$, $(x - 2) = 0$ or $(x - 5) = 0$ or $(x + 3) = 0$

$$\therefore x = 2, x = 5 \text{ or } x = -3.$$

x -intercepts are at $x = 2$, $x = 5$ or $x = -3$ i.e. $(2; 0)$; $(5; 0)$ or $(-3; 0)$

3. Stationary points or turning points:

$$f'(x) = 3x^2 - 8x - 11$$

When $f'(x) = 0$, then $3x^2 - 8x - 11 = 0$

$$(x + 1)(3x - 11) = 0$$

$$x = -1 \text{ or } x = \frac{11}{3}$$

y -values at stationary points: $f(-1) = -1 - 4 + 11 + 30 = 36$ and

$$f\left(\frac{11}{3}\right) = \left(\frac{11}{3}\right)^3 = 4\left(\frac{11}{3}\right)^2 - 11\left(\frac{11}{3}\right) + 30 \approx -14.81 \therefore (-1, 36)$$

$$\text{and } \left(\frac{11}{3}, -14.81\right)$$

4. Point of inflection:

$$f'(x) = 3x^2 - 8x - 11$$

$$f''(x) = 6x - 8.$$

$6x - 8 = 0$ where $x = \frac{8}{6} = \frac{4}{3}$, so point of inflection is at $x = \frac{4}{3}$

y -value at point of inflection:

$$f\left(\frac{4}{3}\right) = 10,59. \therefore \left(\frac{4}{3}, 10,59\right)$$

5. End behaviour: $a > 0$ is positive for very big values of x and negative for very big negative values of x .
6. Plot the points and the end behaviour.
Join the points in a smooth curve.

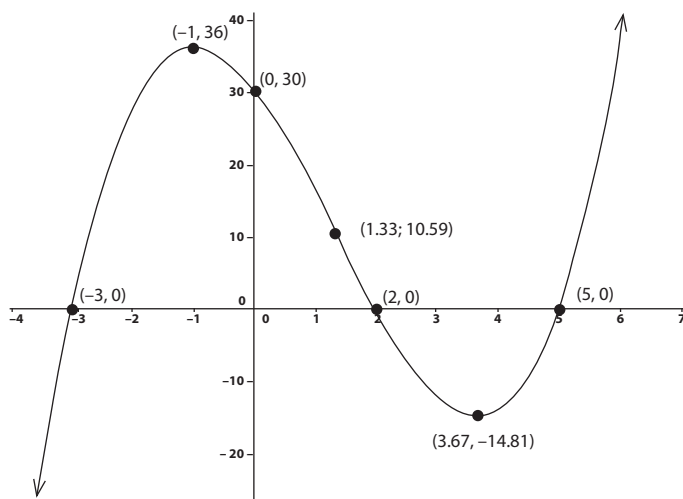
**Activity 5**

1. $f(x) = -x^3 - x^2 + x + 10$
 - a) Write down the coordinates of the y -intercept of f
 - b) Show that $(2; 0)$ is the only x -intercept.
 - c) Calculate the coordinates of the turning points of f
 - d) Sketch the graph of f . Show all intercepts with axes and all turning points.
 - e) Determine the point of inflection. (17)
2. Sketched below is the graph of $g(x) = -2x^3 - 3x^2 + 12x + 20 = -(2x - 5)(x + 2)^2$. A and T are turning points of g . A and B are the x -intercepts of g . P(-3; 11) is a point on the graph.

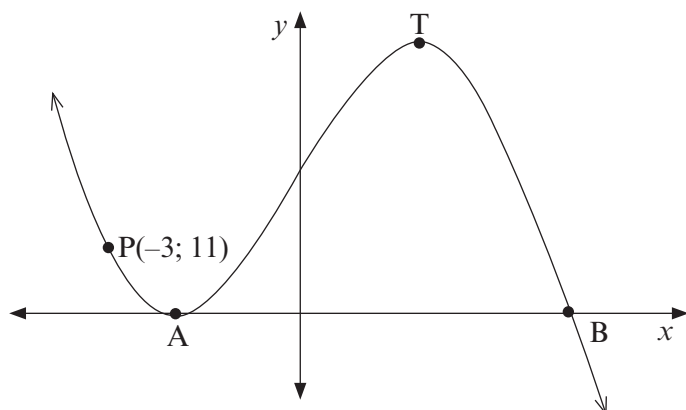

- a) Determine the length of AB.
 b) Determine the x -coordinate of T.
 c) Determine the equation of the tangent to g at $P(-3; 11)$ in the form $y = \dots$
 d) Determine the value(s) of k for which $-2x^3 - 3x^2 + 12x + 20 = k$ has three distinct roots.
 e) Determine the x -coordinate of the point of inflection. (14)

[31]

Solutions

1. a) When $x = 0$, $y = 10$, therefore are $(0; 10)$ ✓ (1)

- b) Assuming that $(2; 0)$ is the x -intercept, then $x - 2$ is a factor of $f(x)$

$$f(x) = -x^3 - x^2 + x + 10 = (x - 2)(-x^2 - 3x - 5) \checkmark \checkmark$$

$$\therefore x - 2 = 0 \text{ or } -x^2 - 3x - 5 = 0 \checkmark$$

$x = 2$ but $-x^2 - 3x - 5 = 0$ has no real solution. Hence $(x - 2)$ is the only x -intercept ✓✓ (5)

- c) At the turning point $f'(x) = -3x^2 - 2x + 1 = 0$ ✓

$$(-3x + 1)(x + 1) = 0$$

$$x = \frac{1}{3} \text{ or } x = -1 \checkmark \checkmark$$

$$\text{When } x = \frac{1}{3}, y = -\frac{1}{27} - \frac{1}{9} + \frac{1}{3} + 10 = \frac{270 - 3 + 9 - 1}{27} = \frac{275}{27} = 10\frac{5}{27}$$

Therefore turning point is $(\frac{1}{3}, \frac{275}{27}) = (\frac{1}{3}, 10\frac{5}{27})$ ✓

$$\text{When } x = -1, y = 1 - 1 - 1 + 10 = 9$$

Therefore turning point is $(-1; 9)$ ✓ (5)

- d)

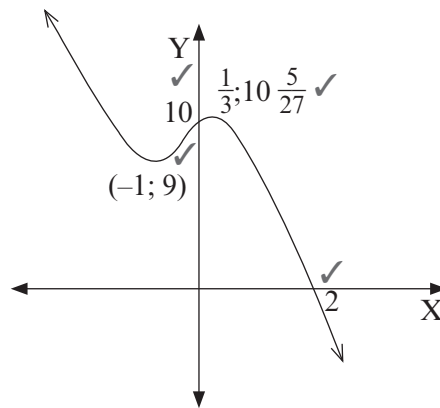

(4)

- e) At the point of inflection $f''(x) = -6x - 2 = 0$ ✓

$$\therefore \text{ at } x = -\frac{2}{6} = -\frac{1}{3} \checkmark$$

(2)

2. a) Since A and B are the x -intercepts of g they are solutions of

$$-(2x - 5)(x + 2)^2 = 0 \checkmark$$

i.e. $x = -2$ and $x = \frac{5}{2}$ The distance between -2 and $\frac{5}{2}$ is $\frac{5}{2} - (-2) = 4,5$ units ✓

(2)

- b) T is a turning point. $g'(x) = -6x^2 - 6x + 12 = 0$ ✓

$$-6(x^2 + x - 2) = 0$$

$$-6(x + 2)(x - 1) = 0$$

When $x = -2$ or $x = 1$. ✓✓

So the x -coordinate of T is 1. (3)

c) $g'(3) = -6(-3)^2 - 6(-3) + 12 = -24$ ✓
 So the equation of the tangent line is $y - 11 = -24(x + 3)$ ✓
 which simplifies to $y = -24x - 61$ ✓ (3)

d) The graph of $y = k$ is shown together with $g(x)$ below.
 Using these graphs we can observe that, provided the line lies above the y -value of A and below that of T, the equation $-2x^3 - 3x^2 + 12x + 20 = k$ will have 3 distinct roots.
 At T, $g(1) = -2 - 3 + 12 + 20 = 27$. So for $0 < k < 27$ the equation has 3 distinct roots. ✓✓✓✓ (4)

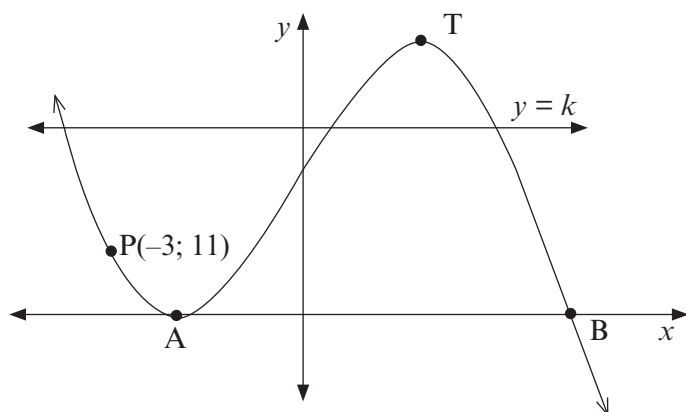

e) $g''(x) = -12x - 6$
 $-12x - 6 = 0$ when $x = \frac{6}{-12} = -\frac{1}{2}$ ✓✓ (2)

[31]

7.5.4 Finding the maximum or minimum

$f'(x) = 0$ shows us the local maximum or minimum points. We can use this to solve an applied problem that asks for a maximum or minimum value.

This is revision of Grade 10 work that is needed in order to help you with some Grade 12 questions about measurement, volume, maximums and minimums. You need to know these formulae and use them to solve problems.

2-D shapes	3-D shapes Right prisms	3-D shapes Where the base is a polygon and the sides meet at one point, the apex.
Area & Perimeter (The distance around the outside)	$V = \text{Area of base} \times \perp \text{ height}$ & Surface area = the sum of the areas of the flat shapes	$V = \frac{1}{3} \text{ Area of base} \times \perp \text{ Height}$ $= \frac{1}{3} A \times H$ Where H is the perpendicular height & Surface area = Area of base + $\frac{1}{2} ph$ where p is the perimeter of the base and h the slant height

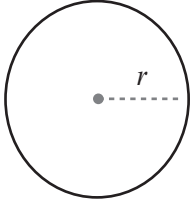
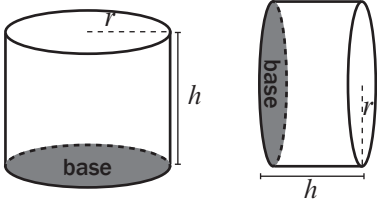
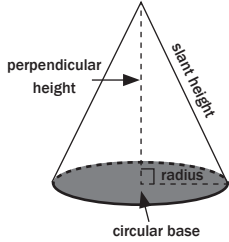
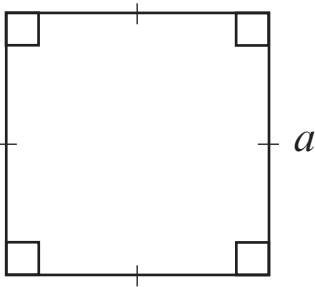
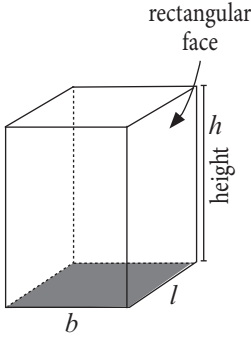
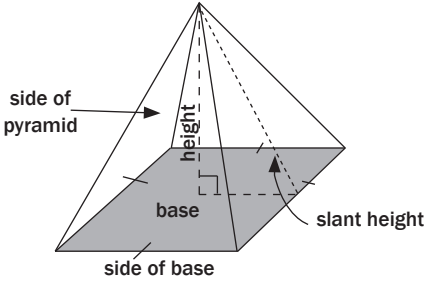
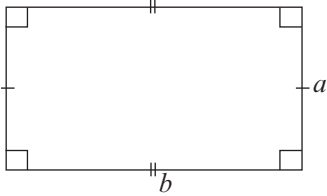
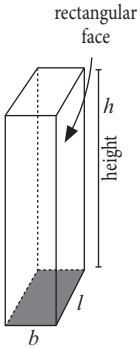
<p>1. Circle</p>  <p>$A = \pi r^2$ Circumference = $2\pi r$ Circumference = $2\pi r$</p>	<p>1. Right cylinders</p>  <p>$V = \pi r^2 \times h$ Surface area = $2\pi r^2 + 2\pi rh$</p>	<p>1. Cones</p>  <p>$V = \frac{1}{3} \pi r^2 \times H$ Surface area = $\pi r^2 + \frac{1}{2} (2\pi r \times h)$ = $\pi r^2 + \pi rh$</p>
<p>2. Square</p>  <p>$A = \text{length} \times \text{length} = a^2$ Perimeter = $4a$</p>	<p>2. Square prism</p>  <p>Note: $l = b = h = a$ $V = a \times a \times a = a^3$ Surface area = $6a^2$</p>	<p>2. Square base pyramid</p>  <p>$V = \frac{1}{3} a^2 \times H$ Surface area = area of square + $4 \times \text{area of triangle}$ = $a^2 + 4 \left(\frac{1}{2} \cdot a \cdot h \right)$ = $a^2 + 2ah$</p>
<p>3. Rectangle</p>  <p>Area: $A = \text{length} \times \text{breadth}$ = ab Perimeter = $2a + 2b$</p>	<p>3. Rectangular prism</p>  <p>$V = l \times b \times h$ Surface area = $2lb + 2lh + 2bh$</p>	<p>The slant height runs from the middle of the edge of the base to the apex.</p> <p>[We calculate the slant heights using the perpendicular height and the dimensions of the base by using the Theorem of Pythagoras.</p>

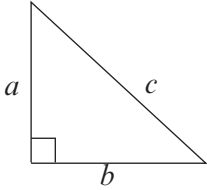
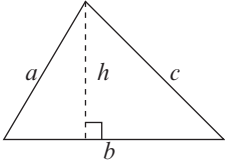
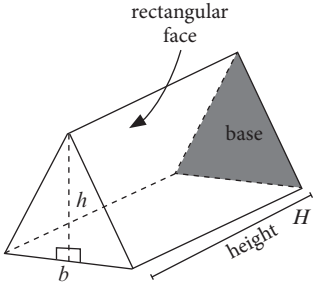
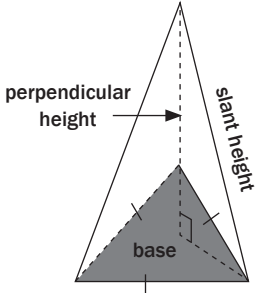
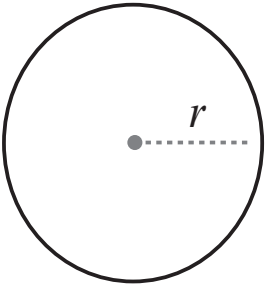
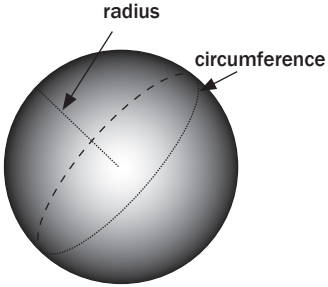
<p>4a. Right-angled triangle</p>  <p>Area: $A = \frac{1}{2} \times \text{base} \times \text{height}$ $= \frac{1}{2} \times b \times a$ Perimeter = $a + b + c$</p> <p>4b. Triangle</p>  <p>Area: $V = \frac{1}{2} \times \text{base} \times \perp \text{ height}$ $= \frac{1}{2} \times b \times h$ Perimeter = $a + b + c$</p>	<p>4. Triangular prism</p>  <p>$V = \left(\frac{1}{2} \times b \times h\right) \times H$ Surface area of triangular prism $= 2 \times \text{area of triangle}$ $+ (\text{sum of areas of 3 rectangles})$</p>	<p>4. Triangular base pyramid</p>  <p>$V = \frac{1}{3} \text{ area of base triangular} \times H$ Surface area = area of base triangular $+ (\text{sum of areas of 3 triangles})$</p>
<p>2-D shapes</p>	<p>3-D shapes</p>	<p>CONVERSIONS</p>
<p>1. Circle</p>  <p>$A = \pi r^2$ Circumference = $2\pi r$</p>	<p>1. Spheres</p>  <p>$V = \frac{4}{3} \pi r^3$ Surface area = $4\pi r^2$</p>	<p>1 millilitre = 1cm^3 $1\text{ m}^3 = 1000 \text{ litres}$</p>



Activity 6

- A drinking glass, in the shape of a cylinder (shown here), must hold 200 ml of liquid when full.

Find the value of r for which the total surface area of the glass is a minimum.
- A rectangular box is constructed in such a way that the length (l) of the base is three times as long as its width. The material used to construct the top and the bottom of the box costs R100 per square metre. The material used to construct the sides of the box costs R50 per square metre. The box must have a volume of 9 m^3 . Let the width of the box be x metres.

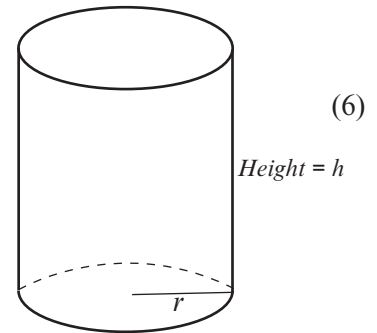

- Determine an expression for the height (h) of the box in terms of x .

- Show that the cost to construct the box can be expressed as

$$C = \frac{1200}{x} + 600x^2$$

- Calculate the width of the box (that is the value of x) if the cost is to be a minimum.

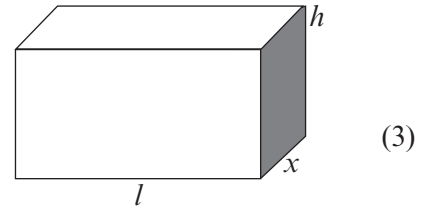

- A tourist travels in a car over a mountainous pass during his trip. The height above sea level of the car, after t minutes, is given as $s(t) = 5t^3 - 65t^2 + 200t + 100$ metres. The journey lasts 8 minutes.

 - How high is the car above sea level when it starts its journey on the mountainous pass?
 - Calculate the car's rate of change of height above sea level with respect to time, 4 minutes after starting the journey on the mountainous pass.
 - Interpret your answer to QUESTION 3.2.
 - How many minutes after the journey has started will the rate of change of height with respect to time be a minimum?

[26]

Solutions

- Find an equation for what you want to minimise:

Surface area of glass = area of base + area of curved surface

$$\text{So } S = \pi r^2 + 2\pi r h \quad \checkmark$$

Because you cannot take the derivative if there are two different variables in the equation (r and h), you must use other information to help you get the equation for what you want to minimise in terms of one variable only.

We know the glass holds $200 \text{ ml} = 200 \text{ cm}^3$.

The volume of the glass is $\pi r^2 h$

$$\text{So } \pi r^2 h = 200 \text{ so } h = \frac{200}{\pi r^2} \quad \checkmark$$

And so we can say

$$S = \pi r^2 + 2\pi r \left(\frac{200}{\pi r^2}\right) = \pi r^2 + \frac{400}{r} \checkmark$$

Now the only variable is r , because π is a constant.

Write S in a way that is easy to find the derivative:

$$S = \pi r^2 + 400r^{-1}$$

Take the derivative of the function you want to minimise:

$$S' = 2\pi r - 400r^{-2} \checkmark$$

Put the derivative equal to 0:

$$2\pi r - 400r^{-2} = 0$$

$$2\pi r = 400r^{-2}$$

$$2\pi r^3 = 400 \quad r \neq 0$$

$$r^3 = \frac{400}{2\pi} \checkmark$$

$$\text{so } r = \sqrt[3]{\frac{400}{2\pi}} \approx 3.99 \text{ cm } \checkmark \quad (6)$$

$$2.1 \text{ Volume} = l \times b \times h \checkmark$$

$$9 = 3x \cdot x \cdot h$$

$$9 = 3x^2 h \checkmark$$

$$h = \frac{3}{x^2} \checkmark \quad (3)$$

$$2.2 \text{ } C = [2(3xh) + 2xh] \times 50 + (2 \times 3x^2) \times 100 \quad (2(3xh) + 2xh) \times 50 + (2 \times 3x^2) \times 100 \checkmark$$

$$= 8x\left(\frac{3}{x^2}\right) \times 50 + 600x^2 \checkmark$$

$$= \frac{1200}{x} 600x^2 \checkmark \quad (3)$$

$$2.3 \text{ } C = \frac{1200}{x} + 600x^2 = 1200x^{-1} + 600x^2 \checkmark$$

$$\frac{dC}{dx} = -1200x^{-2} + 1200x \checkmark$$

$$0 = -\frac{1200}{x^2} + 1200x \checkmark$$

$$\therefore 1200x^3 = 1200$$

$$x^3 = 1$$

$$x = 1 \checkmark \quad (4)$$

$$3.1 \text{ } s(t) = 5t^3 - 65t^2 + 200t + 100$$

$$t = 0 \text{ Therefore it is } 5(0)^3 - 65(0)^2 + 200(0) + 100 = 100 \text{ metres } \checkmark\checkmark \quad (2)$$

$$3.2 \text{ } s'(t) = 15t^2 - 130t + 200 \checkmark$$

$$s'(4) = 15(4)^2 - 130(4) + 200 \checkmark$$

$$= -80 \text{ metres per minute } \checkmark \quad (3)$$

3.3 The height of the car above sea level is decreasing at 80 metres per minute and the car is travelling downwards hence it is a negative rate of change. $\checkmark\checkmark$ (2)

$$3.4 \text{ } s'(t) = 15t^2 - 130t + 200$$

$$s''(t) = 30t - 130 \checkmark$$

$$30t = 130 \checkmark$$

$$\therefore t = \frac{130}{30} \checkmark$$

$$t = 4.33 \quad (3)$$

[26]

What you need to be able to do:

- Determine the average gradient between two points on a curve
- Differentiate from first principles
- Differentiate using the rules
- Determine the equation of tangents
- Use the Remainder and Factor theorem to find factors of equations in the third degree
- Solve equations in the third degree
- Draw a sketch graph of a cubic function using the x - and y -intercepts, turning points and/or stationary points
- Determine the coordinates of the point of inflection
- Discuss the nature of stationary points including local minimum, local maximum and points of inflection
- Use differentiation to maximise or minimise an equation



February/March 2014	Questions 10, 11 and 12
November 2013	Questions 8, 9 and 10
February/March 2012	Questions 8, 9, 10 and 11
November 2012	Questions 8, 9 and 10
February/March 2011	Questions 9, 10 and 11
November 2011	Questions 8, 9, 10 and 11
February/March 2010	Questions 10, 11 and 12
November 2010	Questions 8, 9, and 10
February/March 2009	Questions 11, 12 and 13
November 2009	Questions 10, 11, and 12
	Unused Paper: Questions 9, 10, and 11
November 2008	Questions 8, 9, and 10



Probability

8.1 Revision

Probability is the study of how likely it is that an event will happen. The following questions are typical probability questions:

- What is the chance that it will rain tomorrow?
- If I buy a Lotto ticket, what is the chance that I will win the Lotto?

We can use a **probability scale** to decide what chance there is of an event happening.

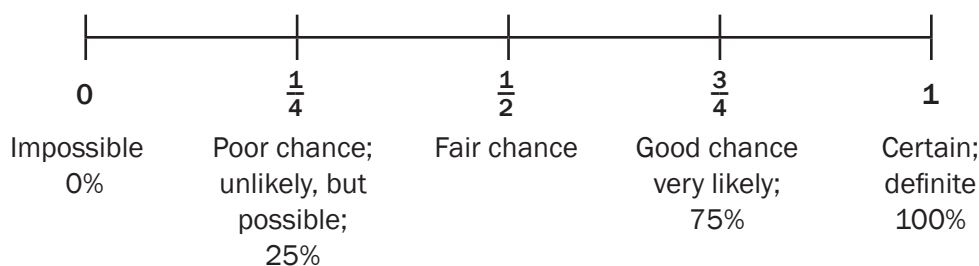

- We can work out the probability using the formula:

$$\text{Probability} = \frac{\text{number of favourable outcomes}}{\text{number of possible outcomes}}$$
- This ratio can be expressed as a common fraction, a decimal fraction or a percentage.
 So a probability of 5 out of 8 can be written as $\frac{5}{8}$ or as 0,625 or as 62,5%.
- Probability always lies **between 0 and 1**, measured as a fraction or as a decimal.
 If probability is shown as a percentage, then it lies **between 0% and 100%**.

8.2 Theoretical probability and relative frequency

If you flip a coin:

- The possible **outcomes** are H (heads) or T (tails).
- There are two possible outcomes. Each has a 50% chance of happening.
- We say that there is a **theoretical probability** of $\frac{1}{2}$ for each outcome.



The theoretical probability of getting the outcome heads (H), is written as $P(H)$.

$$P(H) = \frac{1}{2}$$

Relative frequency

Try this experiment:

- Flip a coin 10 times. Did it land on heads exactly 5 out of 10 times?

e.g. 1

- Mantse flipped a coin 10 times and it landed on heads 7 times. So for her experiment, the relative frequency of heads is $\frac{7}{10}$.
- Jake flips a coin 100 times and records his results. His record shows that he flipped heads 55 times. So the relative frequency of heads is $\frac{55}{100}$. Therefore, the relative frequency of tails is $\frac{45}{100}$.
- Jake flips the coin 1 000 times. Now it is *likely* that heads and tails will come up about the same number of times. He is likely to get heads 499 to 501 times.

Now the relative frequency is equal to or close to the theoretical probability of $\frac{1}{2}$.



Relative frequency is called Empirical probability or Experimental probability

Although the **theoretical probability** of getting heads is $\frac{1}{2}$, your experiment often does not show this exactly. The results of your experiment give you the **relative frequency** of getting heads in that particular experiment.



- An **EVENT** is a happening or an activity that has outcomes or results.

Example:

Rolling an even number is an event with given outcomes.

- An **OUTCOME** is the possible result of an event.

Example:

The possible outcomes of rolling a die are 1, 2, 3, 4, 5 and 6.

- The **SAMPLE SPACE** is the set of all possible outcomes.

Remember: One die, 2 dice



8.3 Venn diagrams

We use Venn diagrams to help us to represent different events. Venn Diagram consists of circles and a rectangle

The rectangle S represents the **sample space** (all of the possible outcomes). Each circle inside S represents a different **event**.

If the two circles intersect, the intersection shows which outcomes belong to both events.

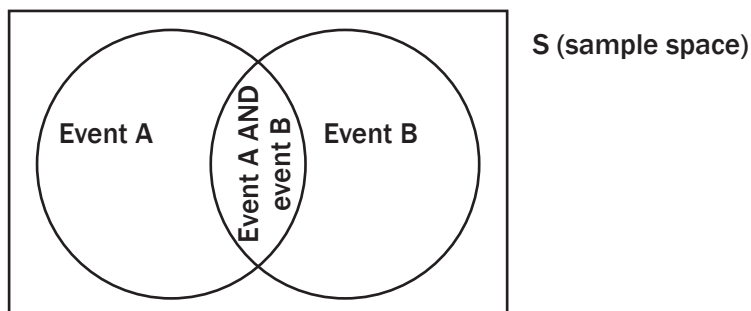

e.g. 2

- Draw a Venn diagram to show the sample space $S = \{1; 2; 3; 4; 5; 6; 7; 8; 9; 10\}$
Indicate the following events in the sample space:
Event A is the set of prime numbers.
 $\therefore A = \{2; 3; 5; 7\}$
Event B is the set of even numbers.
 $\therefore B = \{2; 4; 6; 8; 10\}$

Solution

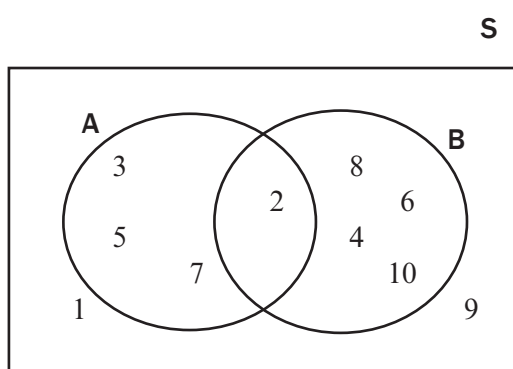

hint

- Both sets have 2 in them, so A and B must intersect.
- Write in 2 first in the intersection.
- Then write in the remaining numbers in each event.
- Check if there are any numbers that are not in Event A or Event B.
- 1 and 9 is part of the sample space, but not in A or in B. Write it in the rectangle, but not in A or B.



Use the Venn diagram in the previous example to determine:

1. $P(A)$
2. $P(B)$
3. $P(A \text{ and } B)$
4. $P(A \text{ or } B)$

Solutions

$$1. P(A) = \frac{4}{10} = \frac{2}{5}$$

$$2. P(B) = \frac{5}{10} = \frac{1}{2}$$

$$3. P(A \text{ and } B) = \frac{1}{10}$$

$$4. P(A \text{ or } B) = \frac{8}{10} = \frac{4}{5}$$



- $P(A) + P(B) - P(A \text{ and } B)$
 $= \frac{4}{10} + \frac{5}{10} - \frac{1}{10} = \frac{8}{10} = \frac{4}{5}$

- $P(A \text{ or } B) = \frac{8}{10} = \frac{4}{5}$

$$\therefore P(A \text{ or } B) = P(A) + P(B) - P(A \text{ and } B)$$

8.4 Mutually exclusive events

Mutually exclusive events are events that cannot happen at the same time. There is no intersection between the events.

- **Mutual:** applies to two or more people or events.
- **Exclude:** to keep out, not allow a person in.
- **Mutually exclusive:** Both events keep the other out. So there is no outcome that can happen in both events at the same time.

e.g. 4

If you roll a die, it is impossible for it to land on a 1 and a 6 at the same time. So P(1) and P(6) are mutually exclusive.

When you roll a die, what are the chances of getting a 6 or a 1?

$$\text{So } P(1 \text{ or } 6) = P(1) + P(6) = \frac{1}{6} + \frac{1}{6} = \frac{2}{6} = \frac{1}{3}$$

So the chance of rolling either a 1 or a 6 is $\frac{1}{3}$ or 33,3%

**S: Possible outcomes
for rolling a die**

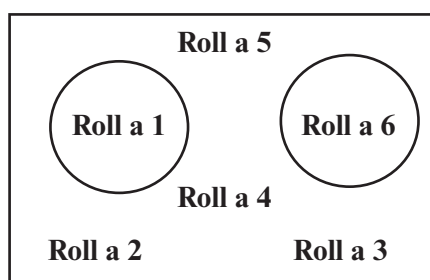

When two events are mutually exclusive, $P(\mathbf{A \text{ and } B}) = 0$

$$\therefore P(\mathbf{A \text{ or } B}) = P(\mathbf{A}) + P(\mathbf{B}) \text{ for mutually exclusive events}$$

We can also use this rule for the number of elements or outcomes in each event, if the events are mutually exclusive:

$$n(\mathbf{A \text{ or } B}) = n(\mathbf{A}) + n(\mathbf{B})$$

When the two events are mutually exclusive, then they do not overlap. Therefore the intersection of A and B is empty and we write $A \cap B = \emptyset$ (empty set) and $P(A \cup B) = 0$



If $P(\mathbf{A \text{ and } B}) = 0$ or if $P(\mathbf{A \text{ or } B}) = P(\mathbf{A}) + P(\mathbf{B})$, then the events are mutually exclusive



- **Complement:** (noun) something that completes an event; it adds what is missing to make up the whole.
- **Complementary:** (adjective) an event that completes or adds to other events to make up the whole sample space.

NOTE: A complement is not the same as a **compliment!**

A **compliment** is a positive comment made to a person or a group of people.

8.5 Complementary events

Events that are **mutually exclusive** and make up the whole sample space are called **complementary events**. There is no intersection and no elements from the sample set are outside the two sets.

The possible events when you roll a die are 1; 2; 3; 4; 5 or 6.

The probability of rolling a 4 is $\frac{1}{6}$.

The probability of not rolling a 4 is $\frac{5}{6}$.

So the event **not** rolling a 4 is the **complement** of the event rolling a 4.

$$\text{So } P(4) + P(4') = \frac{1}{6} + \frac{5}{6} = 1$$

The complementary rule:

$$P(A') + P(A) = 1 \text{ or } P(A') = 1 - P(A)$$

$P(A')$ means probability of 'not A'.

S: Possible outcomes for rolling a die

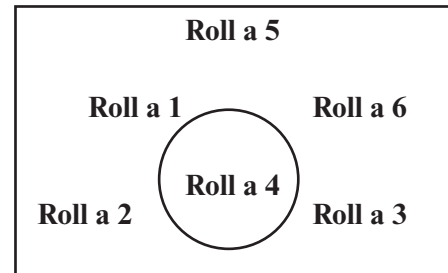

In the example, $n(\text{not rolling a 4}) + n(\text{rolling a 4}) = 5 + 1 = 6$



Activity 1

1. If $S = \{1; 2; 3; 4; 5; 6; 7\}$, $A = \{1; 3; 5; 7\}$ and $B = \{2; 4; 6\}$, what is the probability of choosing a number that is not in set A? (2)
2. $S = \{a; b; c; d; e; f; g; h; i; j\}$ and $A = \{a; e; i\}$, $B = \{b; c; d; f; g; h\}$, $C = \{b; h; j\}$.
 - a) Draw a Venn diagram to represent S. (4)
 - b) Give a description of set A. (1)
 - c) Are there any complementary sets? Explain. (2)
 - d) Which sets are mutually exclusive, but they are not complementary? Give a reason for your answer. (2)
3. A DVD shop has 180 comedies, 250 drama films, 230 science fiction movies and 120 thrillers. If you select a DVD at random, what is the probability that this movie is a comedy OR a thriller? (3)

[14]

Solutions

1. $P(A') = 1 - P(A) = 1 - \frac{4}{7} = \frac{3}{7}$ ✓✓ (2)

2. a) S

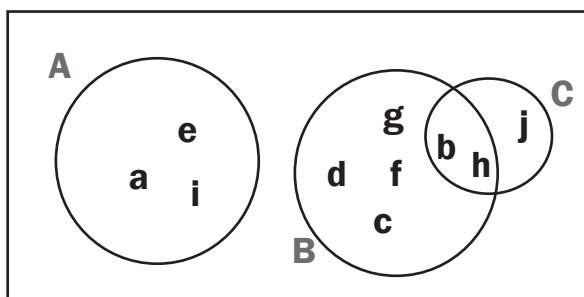

✓✓✓✓(4)

b) Set A is the set of vowels from a to j; or the set of the first three vowels of the alphabet. ✓ (1)

c) Sets A and B are not complementary because they do not include element j. Sets A and C are also not complementary. Sets B and C share elements b and h, so they are not mutually exclusive or complementary. ✓✓ (2)

d) Set A and set B are mutually exclusive, but they are not complementary. They do not share any elements, but they do not make up the whole sample space. Set A and Set C are also mutually exclusive, but not complementary. ✓✓ (2)

3. No DVD is marked as both a comedy and a thriller, so there is no overlap in events. These are mutually exclusive (but not complementary).

There are $250 + 230 + 120 = 600$ DVDs in the sample space.

Use $P(A \text{ or } B) = P(A) + P(B)$.

$$P(\text{comedy or thriller}) = P(\text{comedy}) + P(\text{thriller})$$

$$= \frac{180}{780} \checkmark + \frac{120}{780} \checkmark = \frac{300}{780} = \frac{5}{13} \checkmark \quad (3)$$

[14]

8.6 Events which are not mutually exclusive

Sometimes two events have some outcomes that are the same.

e.g. 5

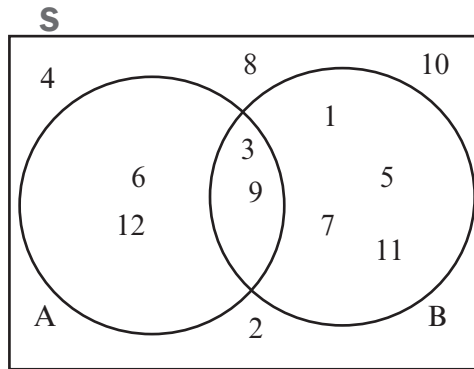

The sample space $S = \{1; 2; 3; 4; 5; 6; 7; 8; 9; 10; 11; 12\}$

In the sample space, event A is the set of multiples of 3.

So Set $A = \{3; 6; 9; 12\}$

Event B is the set of odd numbers.

So $B = \{1; 3; 5; 7; 9; 11\}$

$$P(A) = \frac{\text{favourable outcomes}}{\text{possible outcomes}} = \frac{4}{12} = \frac{1}{3}$$

$$P(B) = \frac{6}{12} = \frac{1}{2}$$

$$\text{So } P(A) + P(B) = \frac{4}{12} + \frac{6}{12} = \frac{10}{12}$$

$P(A \text{ or } B)$ is the chance of getting the numbers in set A or in set B.

We cannot count the 3 and the 9 for both sets. We cannot repeat the numbers in the intersection of set A and set B.

$$\text{So } P(A \text{ or } B) = \frac{8}{12}.$$

So $P(A) + P(B) \neq P(A \text{ or } B)$

To make them equal, we need to subtract the probability of the intersection, $P(A \cap B)$

$P(A) + P(B) - P(A \cap B) = \frac{4}{12} + \frac{6}{12} - \frac{2}{12} = \frac{8}{12}$ This is the answer we found for $P(A \text{ or } B)$.

The ADDITION rule for the probability of ANY two events in a sample space:

$$P(A \text{ or } B) = P(A) + P(B) - P(A \cap B)$$

We can also use this rule for the number of elements or outcomes in each set:

$$n(A \text{ or } B) = n(A) + n(B) - n(A \cap B)$$



Activity 2

In a group of 50 learners, 35 take Mathematics and 30 take History. 12 learners do not take Mathematics or History.

1. Draw a Venn diagram to represent this information. (4)
 2. If a learner is chosen at random from this group, what is the probability that he takes both Mathematics and History? (2)
- [6]**

Solutions

1. Use M for Mathematics and H for History.

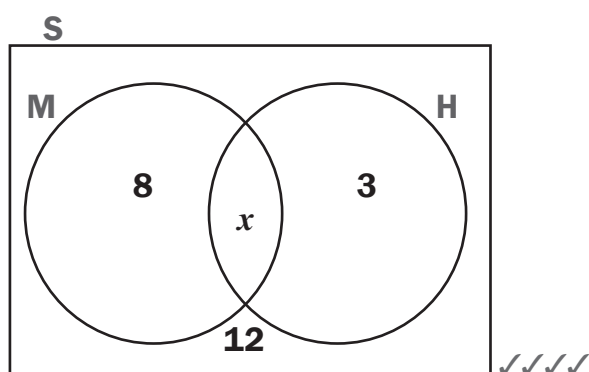

(4)

- Draw the sample space and sets for the events M and H.
- We do not know yet how many learners (outcomes) are in the intersection of M and H.

So let $M \cap H = x$

- We do know that 12 learners are not in M or H.

$$35 - x + x + 30 - x + 12 = 50$$

$$-x = -27$$

$$x = 27$$

So place 27 in the intersection of M and H.

$$M = 35 - 27 = 8$$

$$H = 30 - 27 = 3.$$

2. $P(M \text{ and } H) = \frac{27}{50}$ ✓✓

(2)

[6]

8.7 Summary of symbols and sets used in probability

There are some symbols you need to use when describing probability. We have used some of them already.

To explain the use of each symbol, we will use these sets again:

S = {a; b; c; d; e; f; g; h; i} and A = {a; e; i}, B = {a; b; c; d; f; g;}, where S= Sample Space, A and B are two sets in the sample space

$P(A)$ (A) means the probability that an element from set A will occur.

$$P(A) = \frac{3}{9} = \frac{1}{3}$$

$n(A)$ $n(A)$ means the number of elements in set A.

$$n(A) = 3$$

A' A' means all the elements of the sample space that are NOT in set A. This is the **complement** of set A.

$$A' = \{b; c; d; f; g; h\}$$

\cup $A \cup B$ means the same as A OR B.

It means the **union** of the two sets and represents the total of all the elements that are in set A **or** set B. No elements are repeated.

$$A \cup B = \{a; b; c; d; e; f; g; i\}$$

\cap $A \cap B$ is the same as A **and** B.

It means the **intersection** of sets A and B and represents all the elements that they share. (All the elements that are in both set A **and** set B at the same time). This is where the sets overlap.

$$A \cap B = \{a\}$$

$P(A \cap B)$ $P(A \cap B)$ means the probability that an element from $(A \cap B)$ will occur. $P(A \cap B) = \frac{1}{9}$

$P(A \cup B)$ $P(A \cup B)$ means the probability that an element from $(A \cup B)$ will occur. $P(A \cup B) = \frac{8}{9}$

$n(A \cup B)$ $n(A \cup B)$ means the number of elements in set A or set B. $n(A \cup B) = 8$

$n(A \cap B)$ $n(A \cap B)$ means the number of elements in set A and set B at the same time (the elements they share). $n(A \cap B) = 1$

$(A \cap B)'$ $(A \cap B)'$ means all the elements of the sample space that are NOT in $(A \cap B)$, the complement of $A \cap B$.

$$(A \cap B)' = \{b; c; d; e; f; g; h; i\}$$

$(A \cup B)'$ $(A \cup B)'$ means all the elements of the sample space that are NOT in $(A \cup B)$.

$$(A \cup B)' = \{h\}$$

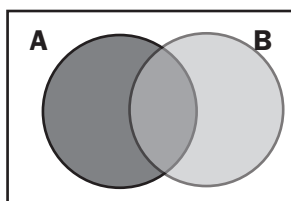

OR

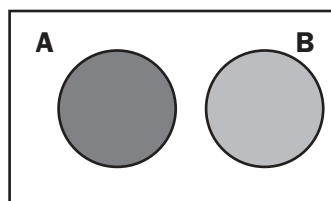

The shaded areas represent:

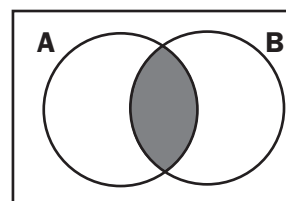
 $(A \text{ or } B) \text{ or } (A \cup B)$ 

The shaded area represents:

 $(A \text{ and } B) \text{ or } (A \cap B)$

You also need to be able to work with three sets in probability, using a Venn diagram and the formulae.

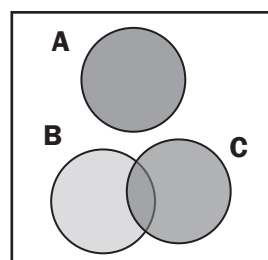
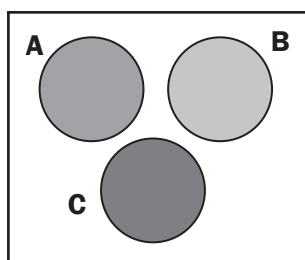
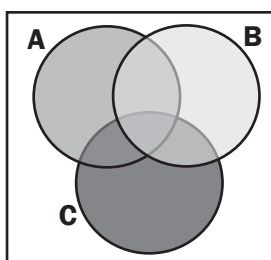

The shaded areas represent:

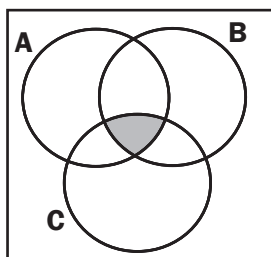
 $(A \text{ or } B \text{ or } C) \text{ or } (A \cup B \cup C)$ 

The shaded area represents:
 $(A \text{ and } B \text{ and } C) \text{ or } (A \cap B \cap C)$

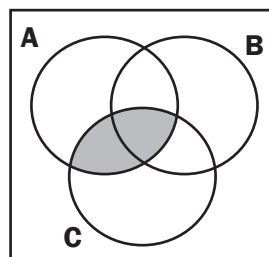

The shaded area represents:
 $(A \text{ and } C) \text{ or } (A \cap C)$

e.g. 6

A survey is conducted with a group of 50 learners to find out what is more popular at the school tuckshop. They are asked if they usually buy toasted sandwiches (T), salads (S) or burgers (B).

They can choose none, one, two or three of the meals.

The survey results are shown with this Venn diagram:

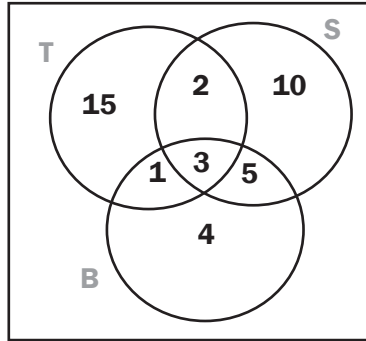

- a) How many people did not buy salads, toasted sandwiches or burgers?
- b) Calculate the probability that a learner selected at random from this survey:
 - i) buys salad, but not toasted sandwiches or burgers.
 - ii) buys toasted sandwiches and salad, but not burgers.
 - iii) buys salad or burgers or both, but not toasted sandwiches.

Solutions:

a) $50 - (15 + 2 + 10 + 1 + 3 + 5 + 4) = 50 - 40 = 10$

10 learners bought none of the items listed.

b) (i) $\frac{10}{50} = \frac{1}{5}$ (ii) $\frac{2}{50} = \frac{1}{25}$ (iii) $\frac{10+5+4}{50} = \frac{19}{50}$



Activity 3

A school organised a camp for 103 Grade 12 learners. The learners were asked which food they prefer for the camp.

They had to choose from chicken (C), vegetables (V) and fish (F).

The following information was collected:

- 2 learners do not eat chicken, fish or vegetables
- 5 learners eat only vegetables
- 2 learners only eat chicken
- 21 learners do not eat fish
- 3 learners eat only fish
- 66 learners eat chicken and fish
- 75 learners eat vegetables and fish

Let the number of learners who eat chicken, vegetables and fish be x .

- a) Draw a Venn diagram to represent the information. (6)
- b) Calculate x . (3)
- c) Calculate the probability that a learner, chosen at random:
 - i) Eats only chicken and fish, and no vegetables. (2)
 - ii) Eats any TWO of the given food choices: chicken, vegetables and fish. (2)

[13]

Solutions:

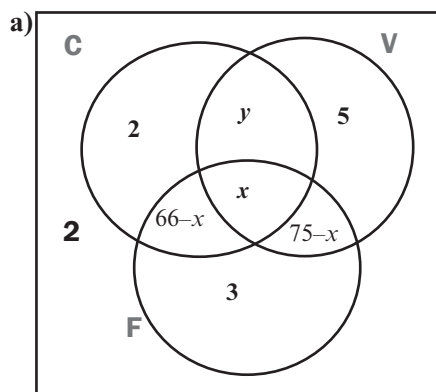

Fill in any given information that you can.

We do not know where these belong yet:

- 21 learners do not eat fish
- 66 learners eat chicken and fish

So let x be learners who eat chicken, fish and vegetables.

Then $66 - x$ is learners who eat only chicken and fish.

Introduce y , the learners who do not eat fish, but do eat chicken and vegetables.

$$\text{Then } 2 + y + 5 + 2 = 21$$

$$\therefore y = 12 \quad \checkmark\checkmark\checkmark\checkmark\checkmark\checkmark(6)$$

$$\text{b) } 2 + 12 + 5 + 66 - x + x + 3 + 75 - x + 2 = 103 \quad \checkmark\checkmark$$

$$-x + 165 = 103$$

$$-x = -62$$

$$x = 62 \quad \checkmark \quad (3)$$

$$\text{c) (i) } \frac{66-x}{103} = \frac{4}{103} \quad \checkmark\checkmark \quad (2)$$

$$\text{(ii) } \frac{4+12+13}{103} = \frac{29}{103} \quad \checkmark\checkmark \quad (2)$$

[13]

8.8 Tree diagrams and contingency tables

1. Independent events

Two successive events are independent if the outcomes of the one event do not influence the outcomes of the other event.

e.g. 7

The probability of flipping a coin and it lands on heads is $P(H) = \frac{1}{2}$.

What is the probability of flipping two coins and they both land on heads?

Solution

There are four possible outcomes:

H and H; H and T; T and H; T and T.

So **H and H** is 1 out of 4 outcomes and $P(H \text{ and } H) = \frac{1}{4}$.

A tree diagram is a picture that helps you to list all possible outcomes of the events.

Here is the tree diagram for $P(H \text{ and } H)$ if you flip a coin twice:

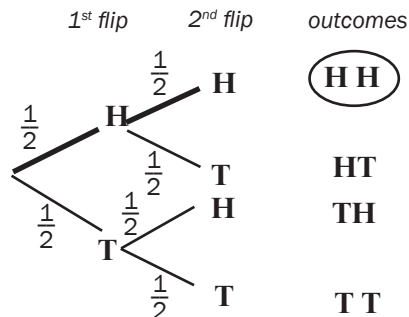

The **tree diagram** shows 4 outcomes.

Each time you flip the coin, the outcomes (heads or tails) do not depend on the outcomes of the last flip. So these events are **independent** of each other.

e.g. 8

You have a pack of cards (no jokers).

What is the probability of these two events?

- **Event A:** Drawing a heart card from a pack of cards and putting it back.
- **Event B:** Drawing a heart card from the pack again.

A and B are independent events. No matter what card is drawn in Event A, it is put back in the pack. So the outcome of event B does not depend on the outcome of event A.



There are 52 cards in a pack (or deck).
There are 4 suits:

hearts; spades; diamonds and clubs.

To **draw a card**, means to take a card out of the pack.

Tree diagram

Here is the tree diagram for all possible outcomes of the two events.

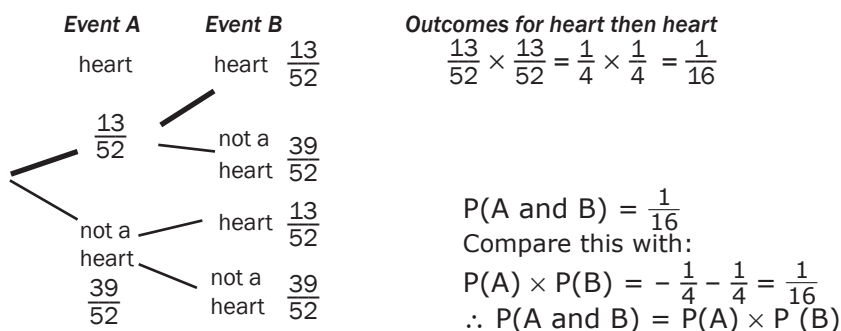

Events are **independent** if the probability of one event happening is not influenced by another event happening. **$P(A \text{ and } B) = P(A) \times P(B)$if the events are independent**

2. Dependent events

Two successive events are dependent if the outcomes of the one event influence the outcomes of the other event.

e.g. 9

What is the probability of these two events?

- Event A: Drawing a heart from a regular pack of cards and **not** putting it back.
- Event B: Drawing a heart again, from the rest of the pack (51 cards left).

Solution

A and B are **dependent** events, because event B depends on the outcomes of event A.

Here is a tree diagram for Event A and Event B.

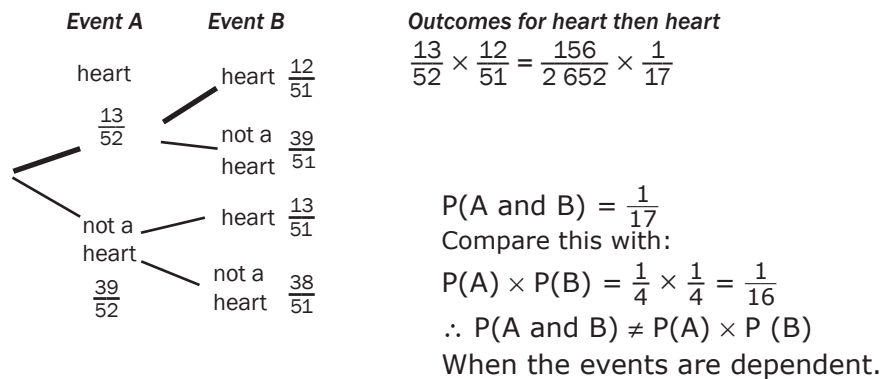

Events are **dependent** if the probability of one event happening is influenced by how another event happens.

$P(A \text{ and } B) \neq P(A) \times P(B)$ for dependant events

8.9 Contingency tables

We can also use a contingency table to represent all possible outcomes of events.

Look at the same example we used for the tree diagram above:

What is the probability of these two events?

- **Event A:** Drawing a heart card from a pack of cards and **putting it back**.
- **Event B:** Drawing a heart card from the pack again.

We can make a table of possible outcomes using columns for the type of card drawn and rows for the events:

	heart	not heart	Total
Event A	13	39	52
Event B	13	39	52
Total	26	78	104

Numbers in each **row** add up to totals on the right.

Numbers in each **column** add up to totals below the table.

e.g. 10

The hair colour of 50 learners was recorded. The table below represents the information

	Girls	Boys	Total
Black	10	12	22
Brown	8	9	17
Blond	6	5	11
Total	24	26	50

Calculate the probability that learner chosen at random:

- 1) will have brown hair
- 2) will have blond hair
- 3) will have black hair or brown hair
- 4) will have blond hair or brown hair or black hair

Solutions

1) 17 learners have brown hair out of a total of 50 $\therefore P(\text{brown hair}) = \frac{17}{50}$

2) 11 learners have blond hair out of a total of 50 $\therefore P(\text{blond hair}) = \frac{11}{50}$

3) $22+17=39$ learners have black or brown hair out of a total of 50
 $\therefore P(\text{black or brown hair}) = \frac{39}{50}$

4) $22+17+11=50$ learners have black or brown or blond hair out of a total of 50
 $\therefore P(\text{black or brown or blond hair}) = \frac{50}{50} = 1$

hint



One die



Two dice



Activity 4

- $P(A) = 0,45$; $P(B) = 0,3$ and $P(A \text{ or } B) = 0,165$.
 Are the events A and B:
 - mutually exclusive
 - independent (7)
- What is the probability of throwing at least one six in four rolls of a regular die? (3)
- What is the probability of throwing four 6s in a row with four rolls of a regular die? (3)
- If two dice are rolled at the same time, what is the probability that the sum of the two numbers is 9? (3)

[16]

Solutions

- $P(A \text{ or } B) = P(A) + P(B) - P(A \text{ and } B)$
 Events A and B are mutually exclusive if $P(A \text{ and } B) = 0$
 \therefore if events are mutually exclusive, then $P(A \text{ or } B) = P(A) + P(B)$
 $P(A \text{ or } B) = 0,165$
 $P(A) + P(B) = 0,45 + 0,3 = 0,75 \checkmark\checkmark$
 $\therefore P(A \text{ or } B) \neq P(A) + P(B) \checkmark$ (3)
 Events A and B are *not* mutually exclusive.
 - Events A and B are independent if $P(A \text{ and } B) = P(A) \times P(B)$
 To work out $P(A \text{ and } B)$, use the rule for $P(A \text{ or } B)$:
 $P(A \text{ or } B) = P(A) + P(B) - P(A \text{ and } B)$ for all events A and B
 $0,165 = 0,45 + 0,3 - P(A \text{ and } B) \checkmark\checkmark$
 $\therefore P(A \text{ and } B) = 0,75 - 0,165 = 0,585 \checkmark$
 But $P(A) = 0,45$ and $P(B) = 0,3 \therefore P(A) \times P(B) = 0,45 \times 0,3 = 0,135 \checkmark$
 $\therefore P(A \text{ and } B) \neq P(A) \times P(B)$
 \therefore Events A and B are *not* independent. (4)
- The probability of not throwing a six in 4 rolls of a die is:
 $P(6) = \left(\frac{5}{6}\right)^4 = \frac{625}{1296}$
 $\therefore P(\text{at least one } 6) = 1 - \frac{625}{1296} = \frac{671}{1296} \checkmark\checkmark\checkmark$ (3)
- Each roll of the die is independent of the previous one.
 $P(\text{four } 6\text{s in a row}) = \frac{1}{6} \times \frac{1}{6} \times \frac{1}{6} \times \frac{1}{6} = \frac{1}{1296} \checkmark\checkmark\checkmark$ (3)

Solutions (continued)

4. Use a table:

Let the columns represent die 1 and the rows represent die 2.

		Die 1					
		1	2	3	4	5	6
Die 2	6	1;6	2;6	3;6	4;6	5;6	6;6
	5	1;5	2;5	3;5	4;5	5;5	6;5
	4	1;4	2;4	3;4	4;4	5;4	6;4
	3	1;3	2;3	3;3	4;3	5;3	6;3
	2	1;2	2;2	3;2	4;2	5;2	6;2
	1	1;1	2;1	3;1	4;1	5;1	6;1

There are 4 throws of both dice that give numbers with a sum of 9.

$$\therefore P(\text{sum of 9}) = \frac{4}{36} = \frac{1}{9} \checkmark\checkmark\checkmark \quad (3)$$

[16]

8.10 Counting principles

Statistics has many applications in everyday life. The tree diagrams and contingency tables used so far are useful if there are not too many outcomes or possibilities. Look at these examples.

e.g. 11

- How many different outfits can be combined using a shirt and a pair of pants from 3 shirts (red, white or blue) and 2 pairs of pants (black or brown)?

SHIRTS: red; white and blue

PANTS: black and brown

Solution

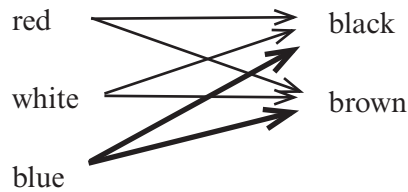

Outcomes:

red/black	red/brown	white/black	∴ 6 different outfits ($3 \times 2 = 6$)
white/brown	blue/black	$\frac{\text{blue}}{\text{brown}}$	

- How many different meals could you have if the menu at a restaurant offered:

Dinner	Drink	Dessert
fried chicken	orange juice	ice cream
fish and chips	Coca-Cola	apple pie
hamburger	coffee	
	tea	

Solution

We can use $3 \times 4 \times 2 = 24$ to find the number of different meals.

We need a more effective way of counting and keeping track of all possibilities.

1. Counting permutations

a) The number of permutations of n different items

e.g. 12

How many different ways could you arrange 4 books on a shelf?

Call them P, Q, R and S.

There are 6 possible outcomes that start with P:

P Q R S

P Q S R

P R S Q

P R Q S

P S R Q

P S Q R

Now start with Q (6 possibilities)

Now start with R (6 possibilities)

Now start with S (6 possibilities)

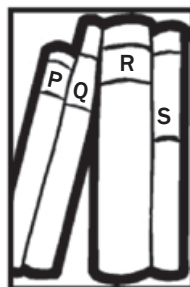

on a

24 different ways to arrange 4 books

Instead of writing down all the possibilities, we can find the answer by using the factorial (!) key on a calculator.

$$4! = 4 \times 3 \times 2 \times 1 = 24$$

Using n factorial ($n!$):

The exclamation mark ! is called the **factorial symbol**.

$4!$ reads as '*four factorial*' and means $4 \times 3 \times 2 \times 1$

$7! = 7 \times 6 \times 5 \times 4 \times 3 \times 2 \times 1 = 5\,040$

b) Permutations of outcomes that are not all distinct (some are the same)

e.g. 13

Consider the word TAN

How many word arrangements can be made with the word TAN

Solution

There are three letters. Possible words are:

TAN TNA ANT ATN NTA NAT

$3! = 3 \times 2 \times 1 = 6$

Permutation

A way of grouping elements of a group in a specific order.

e.g. 14 Consider the word MOM

How many word arrangements can be made with the word MOM if the repeated letters are treated as different letters?

How many word arrangements can be made with the word MOM if the repeated letters are treated as the same letters.

Solutions

- There are three letters. Let us write the first M as M_1 and the second M as M_2
 M_1OM_2 M_1M_2O OM_1M_2 OM_2M_1 M_2OM_1 M_2M_1O
 $\therefore 3! = 3 \times 2 \times 1 = 6$
- If we remove the 1 and the 2 from the letter M, we will obtain the following words:
 MOM MMO OMM
 Therefore, there are only three possible words from the word MOM
 $3 = \frac{3!}{2!}$. The 3! (the numerator) indicates the total number of words formed with three letters and the 2! (the denominator) indicates the number of times a letter is repeated.



Activity 5

- Determine the number of permutations that can be formed from all the letters of the word **ABRACADABRA**. (4)
- Determine the number of permutations that can be formed from all the letters of the word **ABRACADABRA**. This time, the first and last letters must be A. (4)
- Determine the number of permutations that can be formed from all the letters of the word **ABRACADABRA**. This time, all the As have to be next to each other. (4)

[12]

Solutions

- There are 11 letters (so $n = 11$), but some letters are repeated.
 There are 5 As; 2 Bs; 2 Rs; 1 C and 1 D.
 The number of permutations will be $\frac{11!}{5!2!2!1!1!} \checkmark\checkmark\checkmark = 83\,160 \checkmark$ (4)
On a calculator, use the multiplication sign between factorial factors.
- The first and last letters are 'fixed', so there are 9 letters that can change positions ($n = 9$). There are 3 As; 2 Bs; 2 Rs; 1 C and 1 D.
 The number of permutations will be $\frac{9!}{3!2!2!1!1!} \checkmark\checkmark\checkmark = 15\,120 \checkmark$ (4)
- Treat 'AAAAA' as one possible outcome, so we have $n = 7$.
 There are one AAAAA; 2 Bs; 2 Rs; 1 C and 1 D.
 The number of permutations will be $\frac{7!}{1!2!2!1!1!} \checkmark\checkmark\checkmark = 1\,260 \checkmark$ (4)

[12]

C) The number of permutations of m distinct objects taken n at a time

e.g. 15

There are 6 people in a room. Call them A, B, C, D, E and F.
How many different groups of 2 people are possible?

Solution

The question is really – how many permutations of 2 people (A to F) are possible?

We can list them:

AB AC AD AE AF (5)	or	BA CA DA EA FA (5)
BC BD BE BF (4)	or	CB DB EB FB (4)
CD CE CF (3)	or	DC EC FC (3)
DE DF (2)	or	EC FD (2)
EF (1)	or	FE (1)

There are $5 + 4 + 3 + 2 + 1 + 5 + 4 + 3 + 2 + 1 = 30$ different groups of 2 people.

To find this answer without writing all the possibilities out, we can use the formula:

Permutations: ${}^mP_n = \frac{m!}{(m-n)!}$ where m = total number of possibilities n = number of items chosen in a group

$$\text{So } {}^6P_2 = \frac{6!}{(6-2)!} = \frac{6!}{4!} = \frac{6 \times 5 \times 4 \times 3 \times 2 \times 1}{4 \times 3 \times 2 \times 1} = 6 \times 5 = 30$$

Use the factorial key on the calculator, or work it out as shown here.

D) The number of permutations of m items taken n at a time (where the items may be repeated any number of times)

e.g. 16

In a multiple choice test there are 5 questions, each with 4 multiple choice answers. How many possible ways are there of answering the questions if you guess the answers?

Solution

Since you can choose from 4 answers for each question, you can represent the answers with 5 ‘boxes’ of 4 solutions:

$$4 \times 4 \times 4 \times 4 \times 4 = 4^5 = 1\,024$$

e.g. 17

How many three digit numbers can be formed with the digits 0 – 9, if numbers can be repeated?

Solution

10 ‘boxes’ of 3 numbers:
 $10 \times 10 \times 10 = 10^3 = 1\ 000$

SUMMARY

The basic counting principle:

The number of ways of making several decisions in succession (call them m_1 ; m_2 and m_3 etc...) is determined by multiplying the numbers of choices that can be made in each decision. $m_1 \times m_2 \times m_3 \dots$

Permutations

- The number of permutations of m different items is $m!$
- The number of permutations of m items of which:
 a are alike, b are alike, c are alike is: $\frac{m!}{a! \times b! \times c!}$
- The number of permutations of m items taken n at a time, when each of the items may be repeated any number of times, is:
 $m \times m \times m \times m \times \dots$ to n factors = m^n times.
- The number of ways that m items taken n at a time can be arranged, is ${}^m P_n = \frac{m!}{(m-n)!}$



Activity 6

- At Angelo's pizza place you can choose from 6 different types of pasta and 28 different sauces. How many different meals of 1 type of pasta and 1 type of sauce can you have? (2)
- In how many different ways can we arrange 7 books on a shelf? (2)
- In how many different ways can 9 girls sit on one side of a table? (2)
- In how many ways can a three-letter word be made from the letters c; d; e; f without repeating any letters? (3)
- How many possible choices can be made in a multiple choice quiz if there are 4 questions each with 3 answers? (3)
- How many different words can be made using the letters from LIMPOPO? (4)
- How many 3-digit numbers can be made with the digits 1 – 5 if:
 - repetitions are allowed (2)
 - repetitions are not allowed (3)
- A code is made using the format XY^2 , where the X is any letter in the alphabet and Y represents any digit from 0 to 9.
 - How many possible codes can be formed if the letters and digits are repeated? (3)
 - How many possible codes can be formed if the letters and digits are not repeated? (3)

[27]

Solutions

- $6 \times 28 = 168$ different meals. ✓✓ (2)
- $7! = 5\ 040$ different ways 7 books can be arranged on a shelf. ✓✓ (2)
- $9! = 362\ 880$ different ways for 9 girls to sit on one side of a table. ✓✓ (2)
- ${}^4P_3 = \frac{4!}{(4-3)!} = \frac{4!}{1!} = 24$ ways a 3-letter word can be made from c; d; e; f with no repetition. ✓✓✓ (3)
- 4 'boxes' of 3 $\therefore 3 \times 3 \times 3 \times 3 = 3^4 = 81$ possible choices. ✓✓✓ (3)
- LIMPOPO $m = 7$; one L; one I; one M; two Ps; two Os.
 $\frac{7!}{1! \times 1! \times 1! \times 2! \times 2!}$ ✓✓✓ = 1 260 ✓ (4)
- 5 'boxes' of 3 $= 5^3 = 125$ 3-digit numbers (repetitions allowed) ✓✓ (2)
 - ${}^5P_3 = \frac{5!}{(5-3)!} = \frac{5!}{2!} = 60$ 3-digit numbers (no repetition allowed) ✓✓✓ (3)
- In first slot, we have 26 possible options (26 letters in the alphabet)
 In the second slot, we have 10 possible options (digits 0 to 10)
 In the third slot, we have 10 possible options (digits 0 to 10 – the digits may be repeated)
 $\therefore 26 \times 10 \times 10 = 2\ 600$ possible codes ✓✓✓ (3)
 - In first slot, we have 26 possible options (26 letters in the alphabet)
 In the second slot, we have 10 possible options (digits 0 to 10)
 In the third slot, we have 9 possible options (the digits may be repeated)
 $\therefore 26 \times 10 \times 9 = 2\ 340$ possible codes ✓✓✓ (3)

[27]

8.11 Use of counting principles in probability

e.g. 18

1. What is the probability that a random arrangement of the letters of BAFANA starts and ends with an 'A'?
2. A drawer contains 20 envelopes. 8 of the envelopes each contain 5 blue and 3 red sheets of paper. The other 12 envelopes each contain 6 blue and 2 red sheets of paper. One envelope is chosen at random. A sheet of paper is chosen at random from it. What is the probability that this sheet of paper is red?

Solutions

1. There are 6 letters: one B; 3 As; one F and one N.

$$\text{Total number of arrangements of BAFANA} = \frac{6!}{1! \times 3! \times 1! \times 1!} = 120$$

Word starts and ends with A: (A _ _ _ A): one B; one A; one F; one N
(4 letters in the middle)

$$\text{Number of middle arrangements} = \frac{4!}{1! \times 1! \times 1! \times 1!} = 24$$

$$\text{Probability of starting and ending with A} = \frac{24}{120} = \frac{1}{5} = 20\%$$

2. Use a tree diagram:

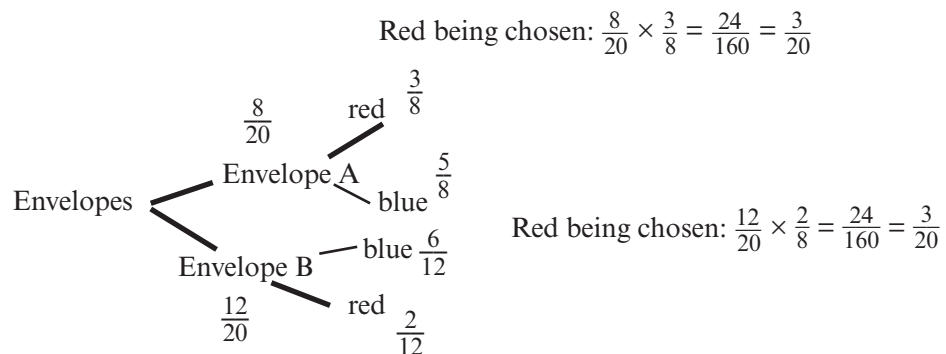

$$\text{Probability of a red sheet of paper being chosen} = \frac{3}{20} + \frac{3}{20} = \frac{6}{20} = 0,30 = 30\%$$

What you need to be able to do:

- Revise the addition rule for mutually exclusive events:
 $P(A \text{ or } B) = P(A) + P(B)$
- Revise the complementary rule: $P(A') = 1 - P(A)$
- Revise the identity $P(A \text{ or } B) = P(A) + P(B) - P(A \text{ and } B)$ for all probability events.
- Identify dependent and independent events and use the product rule
- Use Venn diagrams to solve problems for up to three events.
- Introduce an x for an event to solve problems.
- Use tree diagrams and contingency tables for probability of consecutive events or simultaneous events which are not necessarily independent.
- Understand and use Counting principles in probability.



NOV 2013 P3 Q3, Q4, Q6

FEB/March 201 P3 Q4, Q5 and Q6

FEB/March 2012 P3 Q5, Q6 and Q7

NOV 2011 P3 Q3, Q5, Q6

FEB/March 2011 P3 Q3, Q5, Q6

NOV 2010 P3 Q1, Q5



9

Unit

Analytical Geometry

Analytical geometry works with the Cartesian plane and with algebra to define points, lines and shapes.

9.1 Revise: Analytical Geometry

This topic is also called Coordinate Geometry

1. Gradient of a line

The gradient is the slope of a straight line. It shows how steep the line is.

The steeper the gradient, the bigger the angle it makes with the ground or the positive side of the x -axis.

$$\text{gradient } m = \frac{y_2 - y_1}{x_2 - x_1}$$

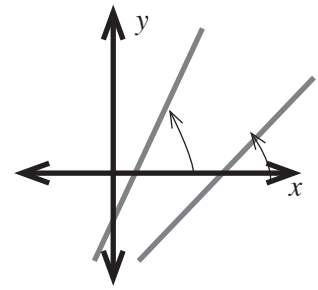

OR

$$\frac{\text{change in } y}{\text{change in } x}$$

where $(x_1; y_1)$ and $(x_2; y_2)$ are two points on the line.

$m < 0$ (negative gradient)

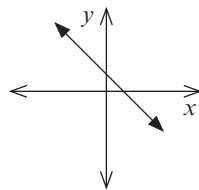

$m = 0$

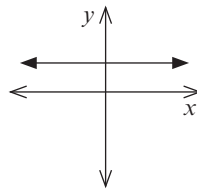

$m > 0$ (positive gradient)

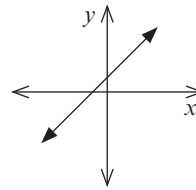

m is undefined

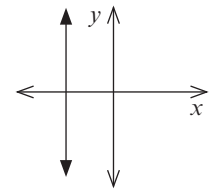

Parallel lines have equal gradients.

$AB \parallel CD$ and $m_{AB} = m_{CD}$

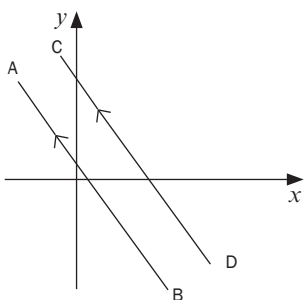

The product of the gradients of lines that are **perpendicular** is -1 .

This means that the gradient of one line is the negative reciprocal of the gradient of the second line:

$AB \perp PQ$

$$m_{AB} \times m_{PQ} = -1$$

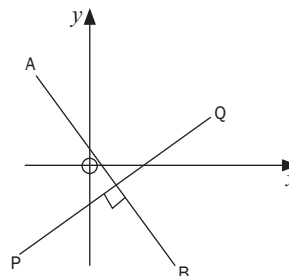

Note: The equation must always be in form $y = mx + c$

e.g. 1

- The graphs of $y = 2x + 1$ and $y = 2x + 5$ are **parallel** because they both have $m = 2$.

The graphs of $y = 2x + 1$ and $y = -\frac{1}{2}x + 5$ are **perpendicular** because $2 \times -\frac{1}{2} = -1$

2. The distance formula

Learn the formula for distance:

$$\text{Length of } AB = \sqrt{(x_2 - x_1)^2 + (y_2 - y_1)^2}$$

You can also find the coordinates for a point on the line using the distance formula.

e.g. 2

- $L(-5;-2)$ and $M(-1;-6)$ are two sets of co-ordinates on the same straight line. Determine the length of LM

$$LM = \sqrt{(x_2 - x_1)^2 + (y_2 - y_1)^2}$$

$$LM = \sqrt{(-5 - (-1))^2 + (-2 - (-6))^2}$$

$$= \sqrt{16 + 16}$$

$$= \sqrt{32}$$

$$= 4\sqrt{2}$$

- The length of the straight line PQ is given as $2\sqrt{5}$. The co-ordinates of P $(5;2)$ and Q $(3;t)$ are given. Find the value(s) of t .

$$PQ = \sqrt{(x_2 - x_1)^2 + (y_2 - y_1)^2}$$

$$2\sqrt{5} = \sqrt{(5 - 3)^2 + (2 - t)^2}$$

$$\sqrt{20} = \sqrt{4 + (4 - 4t + t^2)} \quad \text{square both sides}$$

$$20 = 8 - 4t + t^2$$

$$t^2 - 4t - 12 = 0$$

$$(t - 6)(t + 2) = 0$$

$$t = 6 \text{ or } t = -2$$



Activity 1

1. For a line passing through the two points A(6; 6) and B(3; 2), calculate the length of AB. (3)
2. If PQ = 5 units; P (5; t) and Q (1; -3) determine the possible value(s) of t. (3)

[6]

Solutions

$$\begin{aligned}
 1. \text{ Length AB} &= \sqrt{(x_2 - x_1)^2 + (y_2 - y_1)^2} \checkmark \\
 &= \sqrt{(6 - 3)^2 + (6 - 2)^2} \checkmark \\
 &= \sqrt{3^2 + 4^2} \\
 &= \sqrt{25} \\
 &= 5
 \end{aligned}$$

The length of AB is 5 units. ✓

(3)

$$\begin{aligned}
 2. \text{ PQ} &= \sqrt{(x_Q - x_P)^2 + (y_Q - y_P)^2} \\
 5 &= \sqrt{(1 - 5)^2 + (-3 - t)^2} \\
 &= \sqrt{(-4)^2 + 9 + 6t + t^2} \\
 &= \sqrt{16 + 9 + 6t + t^2} \\
 &= \sqrt{t^2 + 6t + 25} \checkmark
 \end{aligned}$$

$$25 = t^2 + 6t + 25 \quad (\text{square both sides})$$

$$0 = t^2 + 6t \quad \checkmark$$

$$0 = t(t + 6) \quad (\text{factorise by taking out the HCF})$$

$$t = 0 \text{ or } t = -6 \quad \checkmark \quad (\text{both solutions are correct – plot the points to see why!})$$

(3)

[6]

3. The midpoint of a line

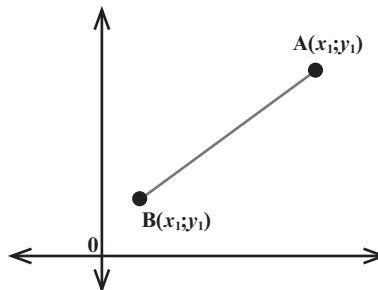

If you know the coordinates of the two endpoints of a line, you can find the point that is halfway between them. This is called the **midpoint**.

The **midpoint** of a line has the coordinates

$$\left(\frac{x_1 + x_2}{2}, \frac{y_1 + y_2}{2} \right)$$

where $(x_1; y_1)$ and $(x_2; y_2)$ are the endpoints of the line.



For a line passing through the two points A(6; 6) and B(3; 2), find the coordinates of the midpoint of AB.

$$\begin{aligned}\text{Midpoint of AB} &= \left(\frac{x_1 + x_2}{2}, \frac{y_1 + y_2}{2} \right) \\ &= \left(\frac{6 + 3}{2}, \frac{6 + 2}{2} \right) = \left(4\frac{1}{2}, 4 \right)\end{aligned}$$

So the midpoint has the coordinates $\left(4\frac{1}{2}, 4 \right)$



The coordinates of the midpoint of the line AB are (1;-4). Find the coordinates of A if the coordinates of B are (4;-3).

When midpoint is given:

$$x \text{ as the midpoint of AB} = \frac{x_A + x_B}{2} \text{ and } y \text{ as midpoint of AB} = \frac{y_A + y_B}{2}$$

$$1 = \frac{x_A + 4}{2} \text{ and } -4 = \frac{y_A - 3}{2}$$

$$2 = x_A + 4 \text{ and } -8 = y_A - 3$$

$$-2 = x_A \text{ and } -5 = y_A$$

Coordinates of A are (-2;-5)



Activity 2

K (-1; -6) and L (5; 4) are two coordinates on the same straight line. Determine the coordinates of the midpoint. (2)

If M (-1; 4) is the midpoint of line segment AB, and the coordinates of A (3;6) are given, find the coordinates of the endpoint B. (3)

[5]

Solutions

$$\begin{aligned}1. \text{ Midpoint of KL} &= \left(\frac{x_1 + x_2}{2}, \frac{y_1 + y_2}{2} \right) \\ &= \left(\frac{-1 + 5}{2}, \frac{-6 + 4}{2} \right) \checkmark \\ &= (2; -1) \checkmark\end{aligned} \quad (2)$$

2. Let B have coordinates $(x_B; y_B)$.

$$(-1; 4) = \left(\frac{3 + x_B}{2}, \frac{6 + y_B}{2} \right) \checkmark$$

$$-1 = \frac{3 + x_B}{2} \quad \text{and} \quad 4 = \frac{6 + y_B}{2}$$

$$(-1)(2) = 3 + x_B \quad (4)(2) = 6 + y_B$$

$$-2 = 3 + x_B \quad 8 = 6 + y_B$$

$$-5 = x_B \checkmark \quad 2 = y_B \checkmark$$

\therefore the coordinates of B are (-5; 2).

We can use coordinate geometry to identify the properties of geometric shapes on the Cartesian plane. (3)

[5]



Activity 3

- A. $(-4; 7)$, B $(4; 5)$, C $(0; -1)$ and D $(a; b)$ are the vertices of parallelogram ABCD.
- Draw the parallelogram on squared paper. (2)
 - Find the midpoint of the diagonal AC. (2)
 - Use the information that you have to find the coordinates of point D. (3)
- [7]

Solutions

a)

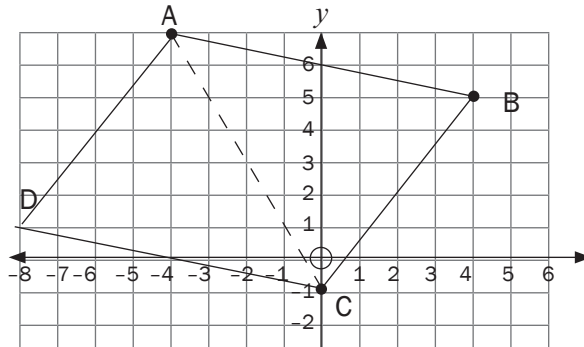

(2)

b) A $(-4; 7)$ and C $(0; -1)$

$$\text{Midpoint} \left(\frac{x_1 + x_2}{2}, \frac{y_1 + y_2}{2} \right) = \left(\frac{-4 + 0}{2}, \frac{7 - 1}{2} \right) = (-2; 3) \checkmark \checkmark$$

So the midpoint of AC is $(-2; 3)$

(2)

c) Diagonals of parallelogram ABCD bisect each other

\therefore midpoint of DB is $(-2; 3)$.

$$\text{So midpoint} (-2; 3) = \left(\frac{4 + a}{2}, \frac{5 + b}{2} \right) \checkmark$$

$$-2 = \frac{4 + a}{2} \quad \text{and} \quad 3 = \frac{5 + b}{2}$$

$$-4 = 4 + a \quad \text{and} \quad 6 = 5 + b$$

$$-8 = a \checkmark \quad \text{and} \quad 1 = b \checkmark$$

\therefore Point D has coordinates $(-8; 1)$

(3)

[7]

9.2 The equation of a line

You can find the equation of a straight line using $y = mx + c$, if you know the gradient m and the y -intercept c .

You can also find the equation of a straight line using $y - y_1 = m(x - x_1)$, if you know the gradient m and any point $(x_1; y_1)$ on the line, or if two points given.

NOTE: y_1 and x_1 are the coordinates of a specific point on the line.

e.g. 5

If the gradient of a line is -2 and the line cuts the y -axis at 1 , then the equation of the line is $y = -2x + 1$.

e.g. 6

If the gradient of a line is -2 and the point $(4; -1)$ lies on the line, find the equation of the line. $y - y_1 = m(x - x_1)$

$$y - (-1) = -2(x - 4) \quad \text{substitute } (4; -1) \text{ into the equation}$$

$$y + 1 = -2x + 8 \quad \text{simplify}$$

$$y = -2x + 7 \quad \text{We usually put the answer in the form } y = mx + c.$$

Summary

If you know	Formulae to use
The gradient and the y -intercept	$y = mx + c$
The gradient and the coordinates of at least one point on the graph.	$y - y_1 = m(x - x_1)$ or $y = mx + c$
Two points on the line: first calculate the gradient and then substitute into $y = mx + c$.	$m = \frac{y_2 - y_1}{x_2 - x_1}$ and $y = mx + c$



Activity 4

- Determine the equation of the straight line that passes through the points P(1; 2) and Q(3; 8) in the form $y = \dots$ (3)
 - Line AB is perpendicular to CD, which has a gradient of -2 . The point (3; 4) lies on AB. Determine the equation of line AB. (2)
- [5]**

Solutions

- First calculate the gradient of PQ:

$$m = \frac{y_2 - y_1}{x_2 - x_1} = \frac{8 - 2}{3 - 1} = \frac{6}{2} = 3 \checkmark$$

Then use the form $y - y_1 = m(x - x_1)$

$$y - y_1 = 3(x - x_1) \checkmark$$

Substituting P(1; 2)

$$y - 2 = 3(x - 1)$$

$$y - 2 = 3x - 3$$

$$\therefore \text{The equation of line PQ is } y = 3x - 1. \checkmark \quad (3)$$

- $m_{CD} = -2$ and $CD \perp AB$.

$$\therefore m_{AB} = \frac{1}{2}$$

So now we have $y = \frac{1}{2}x + c$

Substitute (3; 4) to find the value of c .

$$4 = \frac{1}{2}(3) + c \checkmark$$

$$c = 4 - 1\frac{1}{2}$$

$$\therefore c = 2\frac{1}{2}$$

$$\therefore \text{equation of line AB is } y = \frac{1}{2}x + 2\frac{1}{2} \checkmark \quad (2)$$

[5]

9.3 The inclination of a line

In trigonometry, you used the ratios $\tan \theta$, $\sin \theta$ and $\cos \theta$.

To find the inclination of a line, or the angle it makes with the x -axis, we use $\tan \theta$.

In triangle ABC, $\tan \theta = \frac{\text{opp}}{\text{adj}} = \frac{BC}{AC}$.

$\frac{BC}{AC}$ is also $\frac{\text{change in } y}{\text{change in } x}$ which is the gradient of AB.

We write gradient of AB as m_{AB} .

So we can say $m_{AB} = \tan \theta$

Angle θ shows the slope or **inclination** of the line AB.

θ is called **the angle of inclination**.

NOTE: $\theta \in (0^\circ; 180^\circ)$

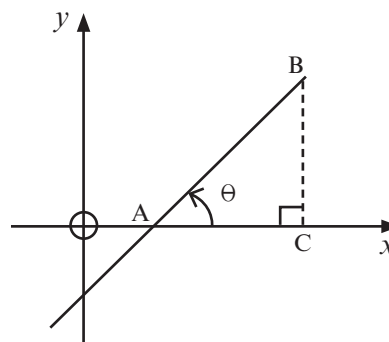

e.g. 7

If $\tan \theta = \frac{1}{2}$, then $\theta = 26,56505 \dots^\circ$ (Press: shift $\tan \frac{1}{2}$ on your calculator)

$\theta = 26,57$ (rounded off to two decimal places)



Activity 5

Give your answers correct to two decimal places.

- Line AB is perpendicular to CD, which has a gradient of -4 .
Find the inclination θ of AB. (2)
 - Determine the inclination of the straight line that passes through the points
P $(-6; 2)$ and Q $(3; 10)$. (2)
 - Given the points A $(-2; -1)$, B $(5; 6)$ and C $(7; -2)$, calculate the size
of $\hat{A}BC$. (6)
- [10]

Solutions

1. $m_{CD} = -4$ and $m_{AB} \perp m_{CD}$, $-4 \times \frac{1}{4} = -1$

So $m_{AB} = \frac{1}{4} \checkmark$

So $\tan \theta = \frac{1}{4} = 0,25$ and $\theta = 14,04^\circ \checkmark$. (2)

2. P $(-6; 2)$ and Q $(3; 10)$

So $m_{PQ} = \frac{y_2 - y_1}{x_2 - x_1} = \frac{10 - 2}{3 - (-6)} = \frac{8}{9} \checkmark \checkmark$

So $\tan \theta = \frac{8}{9}$ [To find θ , use $8 \div 9 = \text{shift tan}$ on your calculator]

Angle of inclination: $\theta = 41,63^\circ$

NOTE: (round off to 2 decimal places) (2)

3. Draw a rough sketch first. Place the triangle on the Cartesian plane.
Use angles α and β

$m_{AB} = \tan \alpha$

$\therefore \tan \alpha = \frac{6 + 1}{5 + 2} = \frac{7}{7} = 1 \checkmark$

$\therefore \alpha = 45^\circ \checkmark$ (special angles)

$m_{BC} = \tan \beta \checkmark$

$\therefore \tan \beta = \frac{-2 - 6}{7 - 5} = \frac{-8}{2} = -4 \checkmark$

$\therefore \beta = -75,963^\circ \dots + 180^\circ$

$= 104,04^\circ \checkmark$

$\hat{A}BC = \beta - \alpha$ (ext angle of Δ)

$= 104,04^\circ - 45^\circ = 59,04^\circ \checkmark$

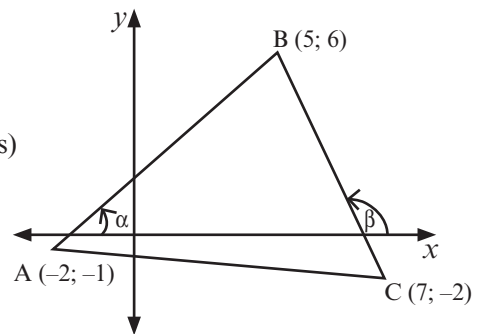

(6)

[10]



Activity 6

1. For a line passing through the two points $A(6; 6)$ and $B(3; 2)$:
 - 1.1 Calculate the length of AB .
 - 1.2 Find the coordinates of the midpoint of AB .
 - 1.3 Calculate the angle of inclination of the line.
 - 1.4 Determine the equation of the line passing through A and B .
 - 1.5 Determine the equation of a line GH perpendicular to AB passing through the midpoint of AB . (11)
2. F, G, H and I are the vertices of a quadrilateral shown below. What kind of quadrilateral is $FGHI$? (5)

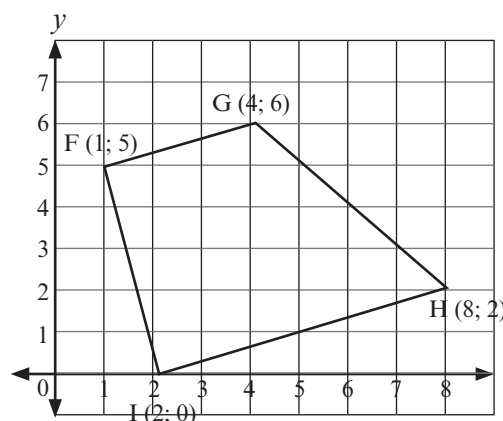

3. $ABCD$ is a quadrilateral with vertices $A(5; 1)$, $B(-3; 5)$, $C(-1; -5)$ and $D(9; -7)$.

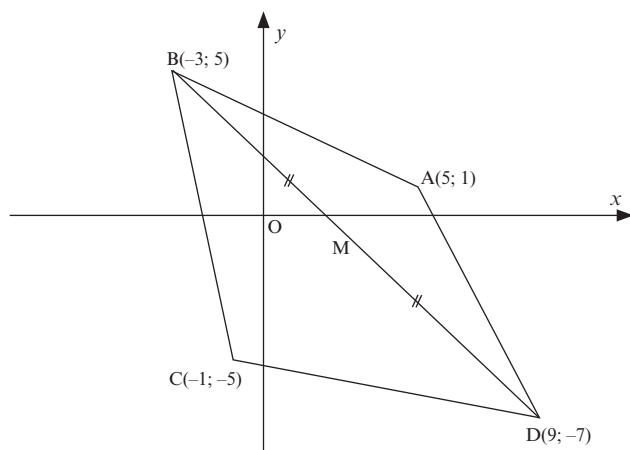

- 3.1 Calculate the gradient of AC . (2)
- 3.2 Determine the equation of AC in the form $y = \dots$ (3)
- 3.3 Hence, or otherwise, show that the midpoint M of BD lies on AC . (3)
- 3.4 Show that $\hat{A}MB = 90^\circ$. (2)
- 3.5 Calculate the area of ΔABC . (5)

[31]

Solutions

1. 1.1 Length $AB = \sqrt{(x_2 - x_1)^2 + (y_2 - y_1)^2} = \sqrt{(6 - 3)^2 + (6 - 2)^2} \checkmark$
 $\sqrt{3^2 + 4^2} = \sqrt{25} = 5$ units

1.2 Midpoint coordinates:

$$\frac{x_1 + x_2}{2} = \frac{3 + 6}{2} = 4\frac{1}{2} \checkmark$$

$$\frac{y_1 + y_2}{2} = \frac{6 + 2}{2} = 4. \quad \text{So the midpoint has the coordinates } (4\frac{1}{2}; 4)$$

1.3 $\tan \theta = m_{AB} = \frac{2 - 6}{3 - 6} = \frac{-4}{-3} = \frac{4}{3} \checkmark \quad \therefore \theta = 53,13^\circ \checkmark$

1.4 $m_{AB} = \frac{4}{3}$ and you know the coordinates of A and B.

$$\text{Use } y - y_1 = m(x - x_1)$$

$$y - y_1 = \frac{4}{3}(x - x_1) \text{ now substitute either point A or point B } \checkmark$$

$$y - 2 = \frac{4}{3}(x - 3) \text{ here point B has been substituted for } (x_1; y_1) \checkmark$$

$$y - 2 = \frac{4}{3}x - 4 \quad \therefore y = \frac{4}{3}x - 2 \checkmark$$

1.5 $AB \perp GH \quad \therefore m_{AB} \times m_{GH} = -1 \checkmark \quad \therefore m_{AB} = \frac{4}{3} \text{ so } m_{GH} = -\frac{3}{4} \checkmark$

The midpoint of AB is $(4\frac{1}{2}; 4)$

$$y - y_1 = m(x - x_1)$$

$$y - 4 = -\frac{3}{4}(x - \frac{9}{2}) \checkmark$$

$$y - 4 = -\frac{3}{4}x + \frac{27}{8}$$

$$y = -\frac{3}{4}x + 3\frac{3}{8} + 4$$

$$y = -\frac{3}{4}x + 7\frac{3}{8} \checkmark \quad (11)$$

2.

$$m_{FG} = \frac{6 - 5}{4 - 1} = \frac{1}{3} \checkmark$$

$$m_{HI} = \frac{2 - 0}{8 - 2} = \frac{2}{6} = \frac{1}{3} \checkmark$$

\therefore FG and HI are parallel.

$$m_{FI} = \frac{0 - 5}{4 - 1} = \frac{-5}{-1} = 5 \checkmark \text{ and } m_{GH} = \frac{2 - 6}{8 - 4} = \frac{-4}{4} = -1 \checkmark$$

so FI is not parallel to GH.

\therefore FGHI is a trapezium (one pair of opp sides \parallel) $\checkmark \quad (5)$

3.

3.1 $m_{AC} = \frac{y_C - y_A}{x_C - x_A}$

\checkmark substitution
 \checkmark answer

$$= \frac{-5 - 1}{-1 - 5}$$

$$= \frac{-6}{-6}$$

$$= 1$$

Answer only: full marks

(2)

3.2

$\checkmark \checkmark$ substitution

$$y - y_1 = m(x - x_1)$$

$$y - 1 = 1(x - 5)$$

$$y = x - 4$$

\checkmark equation

(3)

3.3	$\text{Midpoint of } BD = \left(\frac{x_2 + x_1}{2}, \frac{y_2 + y_1}{2} \right)$ $= \left(\frac{-3 + 9}{2}, \frac{5 - 7}{2} \right)$ $= (3; -1) \quad \checkmark \text{ midpoint } (3;-1)$	
	$\text{line } AC \text{ is } y = x - 4$ $y = 3 - 4$ $y = -1$	\checkmark substitution of M in the equation of line AC
	$\therefore M \text{ lies on } AC.$	\checkmark conclusion (3)
3.4	$M_{AM} = \frac{y_2 - y_1}{x_2 - x_1}$ $= \frac{-1 - 5}{3 + 3}$ $= -1$	\checkmark gradient of AM
	$\text{and } M_{MB} = \frac{-1 - 1}{3 - 5}$ $= 1$	\checkmark gradient of BM
	$M_{AM} \times M_{MB} = -1$	$M_{AM} \times M_{MB} = -1$
	$\therefore \hat{A}MB = 90^\circ.$	(2)
3.5	$BM = \sqrt{(5 + 1)^2 + (-3 - 3)^2}$ $BM = \sqrt{72}$	\checkmark substitution into distance formula
	$AC = \sqrt{(5 + 1)^2 + (1 + 5)^2}$ $AC = \sqrt{72}$	$\checkmark BM = \sqrt{72}$ $\checkmark AC = \sqrt{72}$
	$\text{Area of } \triangle ABC = \frac{1}{2}(\sqrt{72})(\sqrt{72})$ $= 36 \text{ square units}$	\checkmark formula for area of Δ \checkmark answer (5)

[31]

9.4 Circles in analytical geometry

A **circle** is made up of a set of points that are equidistant from its centre.

The **circumference** is the distance around the whole circle.

The distance from the centre to any point on the circumference of the circle is called the **radius** of the circle.

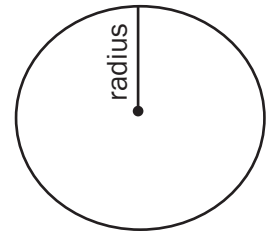

9.4.1 The equation of a circle

CIRCLE WITH CENTRE AT THE ORIGIN

We can use the distance formula to work out the equation of a circle with centre (0; 0).

If P(x; y) is any point on the circle with radius r, then

$$r = \sqrt{(x - 0)^2 + (y - 0)^2}$$

$$r^2 = x^2 + y^2$$

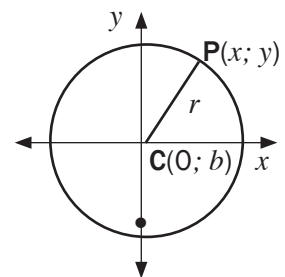

e.g. 8

Find the equation of a circle centre 0 with the point P(5; 2) on its circumference.

$x^2 + y^2 = r^2$ This is the general equation. We just need a value for r^2 .

$(5)^2 + (2)^2 = r^2$ At the point (5; 2)

$$r^2 = 25 + 4 = 29$$

$$\therefore x^2 + y^2 = 29$$

CIRCLES NOT CENTRED AT THE ORIGIN

If we move the centre of the circle to any point on the Cartesian plane C(a; b),

$$\text{then } (x - a)^2 + (y - b)^2 = r^2$$

$$\text{and } r = \sqrt{(x - a)^2 + (y - b)^2}$$

Note: Recap on completing of the square on unit 2

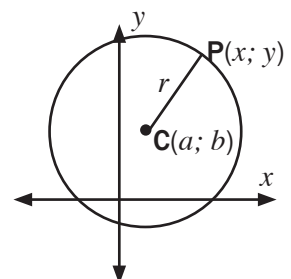



The equation of a circle is $(x + 1)^2 + (y - 3)^2 = 16$.

Determine the coordinates of the centre and the length of the radius.

The equation is already in the form $(x - a)^2 + (y - b)^2 = r^2$,
with $a = -1$, $b = 3$ and $r^2 = 16$

So the centre is $(-1; 3)$ and the radius is $\sqrt{16} = 4$.

Remember that the radius can only be a positive number because it is a length.



Activity 7

- Determine the coordinates of the centre and the length of the radius if a circle has the equation: $x^2 - 2x + y^2 + 10y = -14$ (3)
 - Determine the equation of a circle with centre $C(-1; -2)$ and passing through the point $B(1; -6)$. (3)
- [6]**

Solutions

- To get the equation in the form $(x - a)^2 + (y - b)^2 = r^2$, we need to add in numbers to complete the squares using x^2 with $-2x$ and y^2 with $10y$.

$$(x^2 - 2x) + (y^2 + 10y) = -14$$

$$(x^2 - 2x + 1) + (y^2 + 10y + 25) = -14 + 1 + 25 \checkmark$$

$$(x - 1)^2 + (y + 5)^2 = 12 \checkmark$$

$$\text{So the centre is the point } (1; -5) \text{ and the radius is } \sqrt{12} = \sqrt{2^2 \cdot 3} = 2\sqrt{3} \checkmark \quad (3)$$

- First find the value of r^2 :

$$r^2 = (x - a)^2 + (y - b)^2$$

$$r^2 = (x + 1)^2 + (y + 2)^2 \checkmark$$

Substitute $B(1; -6)$

$$r^2 = (1 + 1)^2 + (-6 + 2)^2 \checkmark$$

$$r^2 = (2)^2 + (-4)^2$$

$$r^2 = 4 + 16 = 20$$

$$\therefore 20 = (x + 1)^2 + (y + 2)^2 \checkmark \quad (3)$$

[6]

9.4.2 The equation of a tangent to a circle

A **tangent** is a straight line which touches a circle at one point only.

So ADB is a tangent, but AP is not a tangent.

A tangent to a circle at any point on the circumference is perpendicular to the radius at that point. So $AB \perp CD$.

We can use all the formulae we know from analytical geometry to solve problems involving a tangent to a circle (distance, midpoint, gradient, angle of inclination, the equation of a line and the equation of a circle).

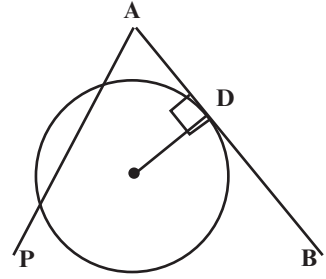

e.g. 10

Find the equation of the tangent APB which touches a circle centre C with equation $(x - 3)^2 + (y + 1)^2 = 20$ at P(5; 3).

Solution

Draw a sketch to help you.

Centre of circle is C(3; -1) so the gradient of the radius CP (m_{CP})

$$\text{is } \frac{3 - (-1)}{5 - 3} = 2.$$

radius \perp tangent, so $m_{APB} \times m_{CP} = -1$ and so

$$m_{APB} = -\frac{1}{2}$$

Equation of tangent: $y - y_1 = m(x - x_1)$

$$y - 3 = -\frac{1}{2}(x - 5) \quad \text{P is a point on the tangent}$$

$$y - 3 = -\frac{1}{2}x + 2\frac{1}{2}$$

$$y = -\frac{1}{2}x + 5\frac{1}{2}$$

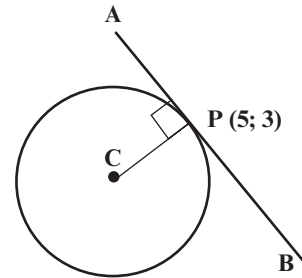



Activity 8

1. ABCD is a quadrilateral with vertices $A(-3; 0)$, $B(-1; -3)$, $C(2; -1)$ and $D(0; 2)$.

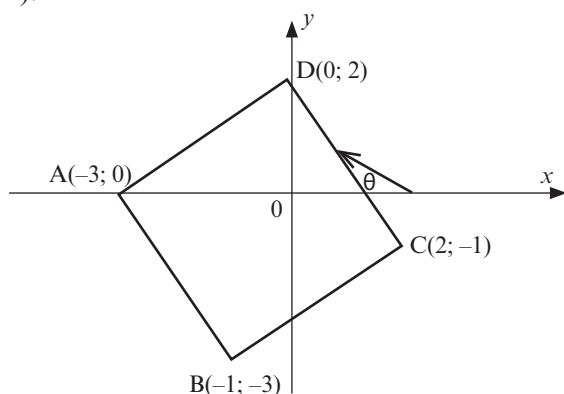

- 1.1 Determine the coordinates of M, the midpoint of AC. (2)
 1.2 Show that AC and BD bisect each other. (3)
 1.3 Prove that $\hat{ADC} = 90^\circ$. (4)
 1.4 Show that ABCD is a square. (4)
 1.5 Determine the size of θ , the angle of inclination of DC, correct to ONE decimal place. (3)
 1.6 Does C lie inside or outside the circle with centre $(0; 0)$ and radius 2? Justify your answer. (2)

[18]

Solutions

1.1 Midpoint M of AC: $\frac{2-3}{2}, \frac{-1+0}{2} = (-\frac{1}{2}; -\frac{1}{2}) \checkmark\checkmark$ (2)

1.2 Midpoint M of BD: $(\frac{-1+0}{2}, \frac{-3+2}{2}) = (-\frac{1}{2}; -\frac{1}{2}) \checkmark\checkmark$

\therefore So the midpoint of AC and the midpoint of BD are the same point, so they bisect each other. \checkmark (3)

1.3 $m_{AD} = \frac{2-0}{0-(-3)} = \frac{2}{3} \checkmark$ and $m_{DC} = \frac{-1-2}{2-0} = -\frac{3}{2} \checkmark$

$m_{AD} \times m_{DC} = \frac{2}{3} \times -\frac{3}{2} = -1 \checkmark$

$\therefore AD \perp DC$

$\therefore \hat{ADC} = 90^\circ \checkmark$ (4)

1.4



There are several ways to prove that ABCD is a square:

- Prove that diagonals are equal and bisect each other at 90°
- Prove that ABCD is a rectangle and has a pair of adjacent sides equal.
- Prove that all four sides are equal and that one internal angle is 90° .

Here is one possible answer:

The diagonals AC and BD bisect each other (proved in 1.2)

$\hat{ADC} = 90^\circ$ (proved in 1.3) \checkmark

$AD^2 = (2-0)^2 + (0-(-3))^2 = 4 + 9 = 13 \checkmark$

$$AD = \sqrt{13}$$

$$CD^2 = (-1 - 2)^2 + (2 - 0)^2 = 9 + 4 = 13 \checkmark$$

$$CD = \sqrt{13}$$

So adjacent sides are equal in length \checkmark

\therefore ABCD is a square. (4)

$$1.5 \tan \theta = m_{DC} = \frac{-1-2}{2-0} = -\frac{3}{2} \checkmark$$

$$\theta = -56,3099324\dots + 180^\circ \checkmark$$

$$\theta = 123,7^\circ \checkmark$$

(3)

$$1.6 \quad OC^2 = (2 - 0)^2 + (-1 - 0)^2$$

$$OC^2 = 4 + 1 = 5 \checkmark$$

$$OC = \sqrt{5}$$

This is longer than the radius of 2 of the given circle, so C(2; -1) lies outside the circle \checkmark . (2)

[18]

2. O is the centre of the circle in the figure below. P(x; y) and Q(12; 5) are two points on the circle. POQ is a straight line. The point R(t; -1) lies on the tangent to the circle at Q.

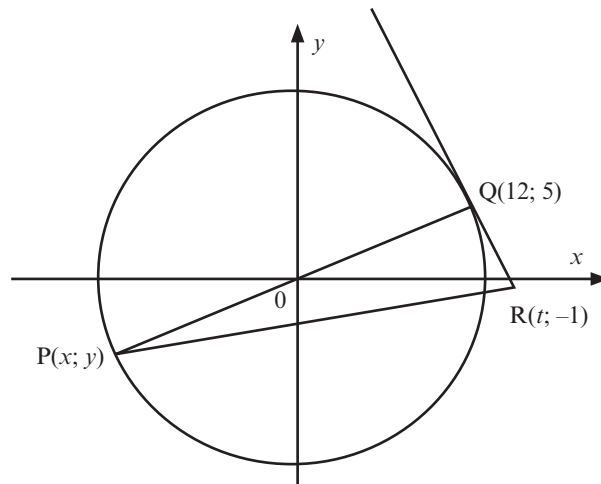

- 2.1 Determine the equation of the circle. (3)
- 2.2 Determine the equation of the straight line through P and Q. (2)
- 2.3 Determine x and y, the coordinates of P. (4)
- 2.4 Show that the gradient of QR is $-\frac{12}{5}$. (2)
- 2.5 Determine the equation of the tangent QR in the form $y = \dots$ (3)
- 2.6 Calculate the value of t. (2)
- 2.7 Determine an equation of the circle with centre Q(12; 5) and passing through the origin. (3)

[19]

Solutions

The centre is at the origin, so $x^2 + y^2 = r^2$.

$$2.1 \quad OQ^2 = (5)^2 + (12)^2 = 25 + 144 = 169 \checkmark \checkmark$$

So the equation of the circle is $x^2 + y^2 = 169 \checkmark$ (3)

$$2.2 \quad m_{PQ} = m_{OQ} = \frac{0-5}{0-12} = \frac{5}{12} \checkmark$$

PQ has y-intercept of 0. \checkmark (2)

$$y = \frac{5}{12}x$$

$$2.3 \quad \text{By symmetry, P is the point } (-12; -5). \checkmark \checkmark \text{ OR}$$

Substitute $y = \frac{5}{12}x$ into $x^2 + y^2 = 169$

$$x^2 + \left(\frac{5}{12}x\right)^2 = 169$$

$$x^2 + \frac{25}{144}x^2 = 169$$

$$144x^2 + 25x^2 = 169 \times 144$$

$$169x^2 = 24\,336$$

$$x^2 = 144$$

$$x = 12 \text{ or } x = -12 \quad x = -12 \text{ according to given diagram } \checkmark$$

$$y = \frac{5}{12}x = \frac{5}{12} \times (-12) = -5 \checkmark$$

So P is the point $(-12; -5)$. (4)

$$2.4 \quad \text{tangent } \perp \text{ radius so } QR \perp PQ \checkmark$$

$$m_{PQ} = \frac{0-5}{0-12} = \frac{5}{12}$$

$$\therefore m_{QR} = -\frac{12}{5} \checkmark$$
 (2)

$$2.5 \quad y = -\frac{12}{5}x + c \checkmark \quad \text{OR} \quad y - y_1 = -\frac{12}{5}(x - x_1) \checkmark$$

Substitute Q(12; 5) into equation to find c:

$$5 = -\frac{12}{5}(12) + c \checkmark \quad y - 5 = -\frac{12}{5}(x - 12) \checkmark$$

$$5 + \frac{144}{5} = c \quad y = -\frac{12}{5}x + \frac{144}{5} + 5$$

$$c = \frac{169}{5} \checkmark \quad y = -\frac{12}{5}x + \frac{169}{5} \checkmark$$

$$y = -\frac{12}{5}x + \frac{169}{5}$$
 (3)

$$2.6 \quad R(t; -1) \text{ lies on line with equation } y = -\frac{12}{5}x + \frac{169}{5}$$

$$\therefore -1 = -\frac{12}{5}t + \frac{169}{5} \checkmark$$

$$-5 = -12t + 169$$

$$12t = 174$$

$$t = 14,5 \checkmark$$
 (2)

$$2.7 \quad OQ^2 = (x - 12)^2 + (y - 5)^2 \quad \checkmark \checkmark \text{ Q(12; 5) is centre of circle}$$

Substitute (0; 0) into equation:

$$OQ^2 = (0 - 12)^2 + (0 - 5)^2$$

$$OQ^2 = 144 + 25 = 169 \checkmark$$

$$\therefore (x - 12)^2 + (y - 5)^2 = 169$$
 (3)

[19]

What you need to be able to do:

From Grade 10 and 11:

- Find the distance between any two points on the Cartesian plane using the distance formula:
- Distance = $\sqrt{(x_2 - x_1)^2 + (y_2 - y_1)^2}$
- Find the midpoint between two points on a line, using the formula $\left(\frac{x_1 + x_2}{2}, \frac{y_1 + y_2}{2}\right)$.
- Find the gradient of line using $m = \frac{y_2 - y_1}{x_2 - x_1}$
- Find the equation of a line given:
 - The gradient and the y-intercept using $y = mx + c$
 - The gradient and the coordinates of at least one point on the graph.
 - You can use $y - y_1 = m(x - x_1)$
 - Two points on the line: first calculate the gradient, then substitute one of the points into $y = mx + c$.
- Find the inclination θ of a line, where $m = \tan \theta$.
- Find other angles, using geometry.

From Grade 12:

- Determine the equation of a circle with radius r and centre $(a; b)$.
- Determine the equation of a tangent to a circle centre $(a; b)$
- Know the properties of triangles (isosceles, scalene, equilateral, right-angled triangle); square, rectangle, trapezium, rhombus and parallelogram.



Trigonometry

10.1 Revise: Trig ratios

Trigonometry is the study of the relationship between the sides and angles of triangles.

The word trigonometry means ‘measurement of triangles’.

The trigonometric ratios

Using θ as the **reference angle** in $\triangle ABO$

- The side opposite the 90° is the hypotenuse side, therefore side AO is the hypotenuse side.
- The side opposite θ is the opposite side, therefore AB is the opposite side.
- The side adjacent to θ is called the adjacent side, therefore OB is the adjacent side.

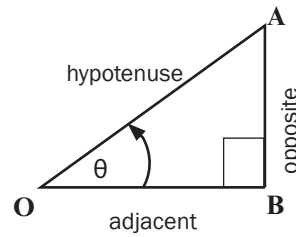

We work with the ratios of the sides of the triangle:

- The ratio $\frac{\text{opposite}}{\text{hypotenuse}}$ is called **sine** θ (abbreviated to **sin** θ)
- The ratio $\frac{\text{adjacent}}{\text{hypotenuse}}$ is called **cosine** θ (abbreviated to **cos** θ)
- The ratio $\frac{\text{opposite}}{\text{adjacent}}$ is called **tangent** θ (abbreviated to **tan** θ)

Therefore

$$\sin \theta = \frac{\text{opposite side}}{\text{hypotenuse}} = \frac{AB}{AO}$$

$$\cos \theta = \frac{\text{adjacent side}}{\text{hypotenuse}} = \frac{OB}{AO}$$

$$\tan \theta = \frac{\text{opposite side}}{\text{adjacent side}} = \frac{AB}{OB}$$

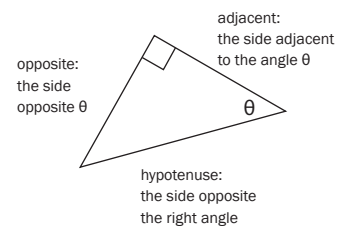
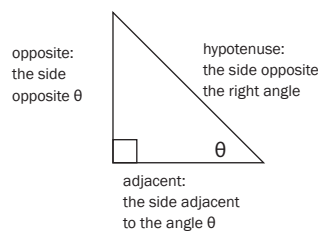

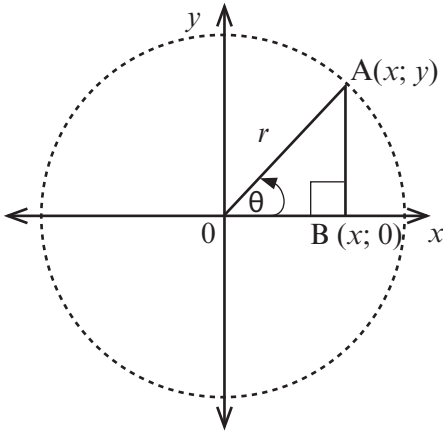

We can also place the same triangle on the Cartesian plane in **standard position**, with a vertex at the origin and one side on the x -axis like this:

- On the Cartesian plane, A is the point $(x; y)$.
- The angle $\hat{A}OB$ or θ is positive (we rotate in an anti-clockwise direction)
- The length of OB is x units and the length of AB is y units.
- We can find the length of AO, using the Theorem of Pythagoras.

In $\triangle ABO$, $AO^2 = AB^2 + OB^2$

$$AO^2 = x^2 + y^2$$

$$r^2 = x^2 + y^2$$



The Theorem of Pythagoras

In any right-angled triangle, the square on the hypotenuse is equal to the sum of the squares on the other two sides.



NOTE:

Look at the circle centre O. AO is also a **radius** of this circle.

Now we can name the trigonometric ratios in terms of x , y and r .

- The ratio $\frac{y}{r}$ is called **sin** θ
- The ratio $\frac{x}{r}$ is called **cos** θ
- The ratio $\frac{y}{x}$ is called **tan** θ

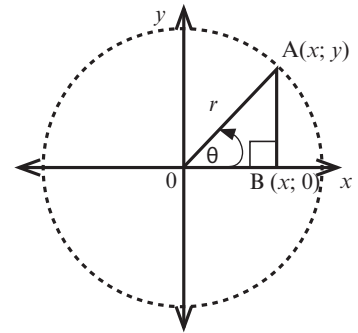

Learn these ratios:

$$\sin \theta = \frac{y}{r} = \frac{\text{opposite}}{\text{hypotenuse}} \quad \cos \theta = \frac{x}{r} = \frac{\text{adjacent}}{\text{hypotenuse}} \quad \tan \theta = \frac{y}{x} = \frac{\text{opposite}}{\text{adjacent}}$$



Remember the word SOHCAHTOA:

S O H	C A H	T O A
$\sin \theta = \frac{O}{H}$	$\cos \theta = \frac{A}{H}$	$\tan \theta = \frac{O}{A}$

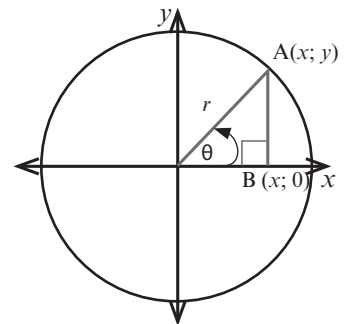



Activity 1

1. $\triangle MNP$ is a right-angled triangle. Write down the trig ratios for:

a) $\sin \alpha$ b) $\sin \beta$

c) $\tan \beta$ d) $\cos \alpha$

2. If $MP = 13$ and $NP = 5$, calculate $\cos \beta$.

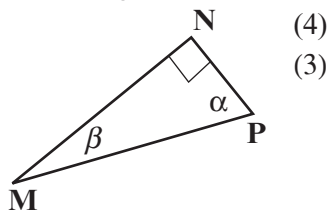

[7]

Solutions

1. a) $\sin \alpha = \frac{MN}{MP}$ ✓ (1) b) $\sin \beta = \frac{NP}{MP}$ ✓ (1)

c) $\tan \beta = \frac{NP}{MN}$ ✓ (1) d) $\cos \alpha = \frac{NP}{MP}$ ✓ (1) (4)

2. $MP = 13$ and $NP = 5$, so we can find MN ,

$MP^2 = MN^2 + NP^2$ Pythagoras ✓

$13^2 = MN^2 + 5^2$

$169 = MN^2 + 25$

$MN^2 = 169 - 25$

$MN^2 = 144$ ✓

$\therefore MN = 12$

$\cos \beta = \frac{MN}{MP} = \frac{12}{13}$ ✓ (3)

[7]

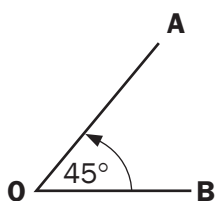

Angles measured in an anti-clockwise direction from the x -axis are positive

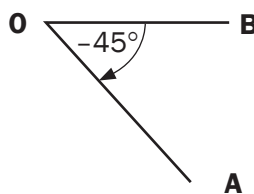

Angles measured in an anti-clockwise direction from the x -axis are negative.
 \therefore angle is negative

10.2 Trig ratios in all the quadrants of the Cartesian plane

The Cartesian plane has four quadrants (quarters). We label them 1, 2, 3 and 4 starting from the quadrant with positive x - and y -values. We can calculate trig ratios for any angle size in the Cartesian plane.



CAST

For trig ratios that are positive in the 4 quadrants.

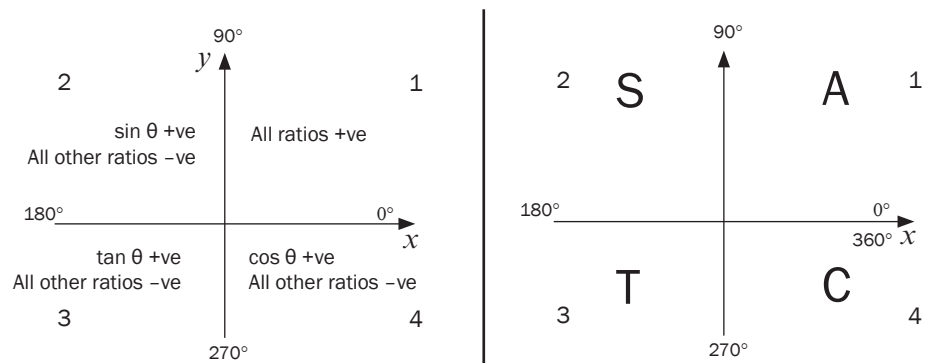

- In the first quadrant x , y and r are positive. Therefore, all the trig functions are positive.
- In the second quadrant, y and r are positive, therefore $\sin \theta$ is positive. In the second quadrant, x is negative, therefore $\cos \theta$ and $\tan \theta$ are negative.
- In the third quadrant, x and y are negative, therefore $\tan \theta$ is positive. In the third quadrant, r is positive, therefore $\cos \theta$ and $\sin \theta$ are negative.
- In the fourth quadrant, x and r are positive, therefore $\cos \theta$ is positive. In the fourth quadrant, y is negative, therefore $\sin \theta$ and $\tan \theta$ are negative.



Activity 2

1. If $\sin \theta$ is negative and $\cos \theta$ is positive, then which statement is true?
 - A. $0^\circ < \theta < 90^\circ$
 - B. $90^\circ < \theta < 180^\circ$
 - C. $180^\circ < \theta < 270^\circ$
 - D. $270^\circ < \theta < 360^\circ$
2. If $\tan \theta < 0$ and $\cos \theta < 0$, then which statement is true?
 - A. $0^\circ < \theta < 90^\circ$
 - B. $90^\circ < \theta < 180^\circ$
 - C. $180^\circ < \theta < 270^\circ$
 - D. $270^\circ < \theta < 360^\circ$
3. Will the following trig ratios be positive or negative?
 - a) $\sin 315^\circ$
 - b) $\cos (-215^\circ)$
 - c) $\tan 215^\circ$
 - d) $\cos 390^\circ$

(1)

(1)

(4)

[6]

Solutions

1. $\sin \theta$ is negative in 3rd and 4th quadrants; $\cos \theta$ is positive in 1st and 4th quadrants.
So θ is in the 4th quadrant. **D. $270^\circ < \theta < 360^\circ$** ✓
2. $\tan \theta < 0$ in 2nd and 4th quadrants; $\cos \theta < 0$ in 2nd and 3rd quadrants.
So θ is in the 2nd quadrant. **B. $90^\circ < \theta < 180^\circ$** ✓
3. a) $\sin 315^\circ$ is in 4th quadrant so it is negative. ✓
- b) $\cos (-215^\circ)$ is in 2nd quadrant so it is negative. ✓
- c) $\tan 215^\circ$ is in 3rd quadrant, so it is positive. ✓
- d) $\cos 390^\circ$ is the same as $\cos 30^\circ$ in the 1st quadrant, so it is positive. ✓

[6]

10.3 Solving triangles with trig

For some trigonometry problems, it is helpful to draw a diagram showing the angle involved and the x , y and r values.

e.g. 1

If $\tan \theta = -\sqrt{3}$ and $180^\circ < \theta < 360^\circ$, determine, using a diagram, the value of:

- a) $\sin \theta$ b) $3 \cos \theta$

Solutions

a) $\tan \theta = \frac{y}{x} = \frac{-\sqrt{3}}{1}$.

$180^\circ < \theta < 360^\circ$ and $\tan \theta$ is negative in the 4th quadrant

By Pythagoras, $r^2 = x^2 + y^2$

$$r^2 = (1)^2 + (-\sqrt{3})^2$$

$$r^2 = 1 + 3 = 4$$

$$r = 2 \checkmark$$

$$\therefore \sin \theta = \frac{y}{r} = \frac{-\sqrt{3}}{2} \checkmark (4)$$

b) $3 \cos \theta$

$$= 3\left(\frac{x}{r}\right) = 3\left(\frac{1}{2}\right) \checkmark = \frac{3}{2} = 1,5 \checkmark (2)$$

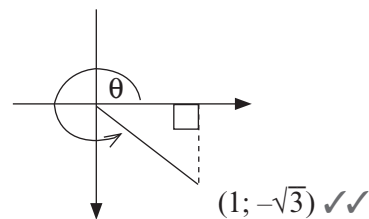

[6]



Activity 3

If $\cos \beta = \frac{p}{\sqrt{5}}$ where $p < 0$ and $\beta \in [180^\circ; 360^\circ]$, determine, using a diagram, an expression in terms of p for:

- a) $\tan \beta$ b) $2 \cos^2 \beta - 1$

[6]

Solutions

a) $\cos \beta = \frac{p}{\sqrt{5}} = \frac{x}{r}$; so $x = p$ and $r = \sqrt{5}$

By Pythagoras, $y^2 = r^2 - x^2$

$$\therefore y^2 = (\sqrt{5})^2 - p^2$$

$$= 5 - p^2$$

$$\therefore y = \pm \sqrt{5 - p^2}$$

$$\therefore y = -\sqrt{5 - p^2} \checkmark \text{ since } \beta \text{ is in quadrant 3, } y \text{ is negative}$$

$$\therefore \tan \beta = \frac{-\sqrt{5 - p^2}}{p} \checkmark (4)$$

b) $2 \cos^2 \beta - 1 = 2 \left(\frac{p}{\sqrt{5}}\right)^2 - 1 \checkmark$

$$= \frac{2p^2}{5} - 1 \checkmark (2)$$

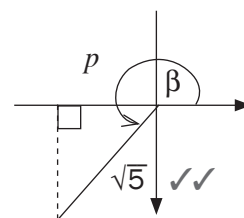

[6]

10.4 Using a calculator to find trig ratios

The scientific calculator calculates trigonometric ratios as decimal fractions.



1. $\sin 58^\circ = 0,8480480962\dots$ [Press: sin 58 =]
2. $\cos 222^\circ = -0,7431448255\dots$ [Press: cos 222 =]
3. Calculate (correct to 2 decimal places):
 $\cos 238^\circ \tan 132^\circ = 0,5885349 \dots \approx 0,59$ (to 2 decimal places)
 [Press: cos 238 × tan 132 =]
4. $\frac{\sin^2 327}{5 + \tan 37} = 0,05155 \dots \approx 0,052$ [NOTE: $\sin^2 327^\circ = (\sin 327^\circ)^2$]
5. $\sin 30^\circ = \frac{1}{2}$

10.5 The trig ratios of special angles

1. Special trig ratios using the unit circle

Consider a circle on the Cartesian plane that has a radius of **one unit**.

We can find the trig ratios for 0° (or 360°), 90° , 180° and 270° using the unit circle.

Label the $(x; y)$ coordinates on each axis.

Label the angles on each axis.

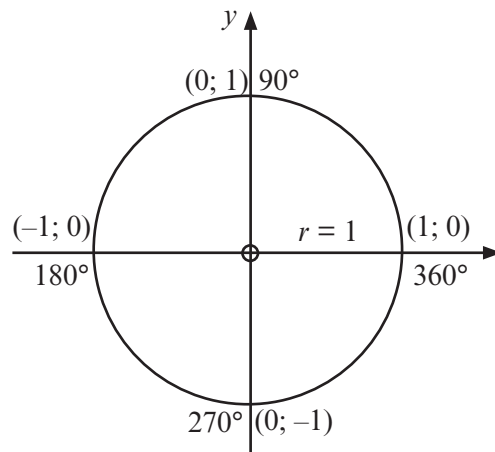

From the unit circle:

- At 0 or 360° : $x = 1, y = 0$ and $r = 1$
- At 90° : $x = 0, y = 1$ and $r = 1$
- At 180° : $x = -1, y = 0$ and $r = 1$
- At 27° : $x = 0, y = -1$ and $r = 1$

$$\sin 0^\circ = \frac{0}{1} = 0$$

$$\sin 90^\circ = \frac{1}{1} = 1$$

$$\cos 0^\circ = \frac{1}{1} = 1$$

$$\cos 90^\circ = \frac{0}{1} = 0$$

$$\tan 0^\circ = \frac{0}{1} = 0$$

$$\tan 90^\circ = \frac{1}{0} \text{ is undefined}$$

$$\sin 180^\circ = \frac{0}{1} = 0$$

$$\sin 270^\circ = \frac{-1}{1} = -1$$

$$\cos 180^\circ = \frac{-1}{1} = -1$$

$$\cos 270^\circ = \frac{0}{1} = 0$$

$$\tan 180^\circ = \frac{0}{-1} = 0$$

$$\tan 270^\circ = \frac{-1}{0} \text{ is undefined}$$



NB

Summary

θ	0°	90°	180°	270°	360°
$\sin \theta$	0	1	0	-1	0
$\cos \theta$	1	0	-1	0	1
$\tan \theta$	0	undefined	0	undefined	0

2. Special trig ratios using an equilateral triangle

We use an equilateral triangle that has sides of **2 units** to find the trig ratios for the special angles 30° and 60° . The perpendicular bisector of one side creates two triangles. The angles of an equilateral triangle are equal, so angles P, Q and R are each 60° .

P is bisected, so $\widehat{QPS} = \widehat{RPS} = 30^\circ$.

By Pythagoras,

$$PR^2 = PS^2 + RS^2$$

$$2^2 = PS^2 + 1^2$$

$$PS^2 = 4 - 1 = 3$$

$$\therefore PS = \sqrt{3}$$

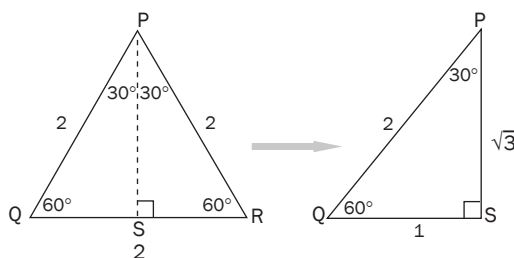

Now we can use ΔPQS to work out trig ratios of 30° and 60° .



$$\sin 60^\circ = \frac{\sqrt{3}}{2}$$

$$\sin 30^\circ = \frac{1}{2}$$

$$\cos 30^\circ = \frac{\sqrt{3}}{2}$$

$$\cos 60^\circ = \frac{1}{2}$$

$$\tan 30^\circ = \frac{1}{\sqrt{3}}$$

$$\tan 60^\circ = \frac{\sqrt{3}}{1} = \sqrt{3}$$

3. Special trig ratios using a right-angled isosceles triangle

Use a right-angled isosceles triangle with sides of **one unit** to work out the trig ratios for 45° . The angles opposite the equal sides are equal, so they are each 45° (sum of angles in Δ).

By Pythagoras,

$$AC^2 = AB^2 + BC^2$$

$$AC^2 = 1^2 + 1^2$$

$$AC^2 = 1 + 1 = 2$$

$$\therefore AC = \sqrt{2}$$

The hypotenuse will be $\sqrt{2}$ units.

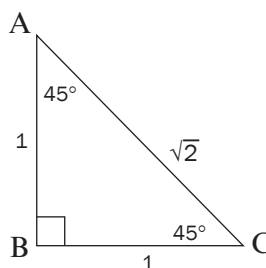

$$\sin 45^\circ = \frac{1}{\sqrt{2}} = \frac{\sqrt{2}}{2}$$

$$\cos 45^\circ = \frac{1}{\sqrt{2}} = \frac{\sqrt{2}}{2}$$

$$\tan 45^\circ = \frac{1}{1} = 1$$

Summary of special angles

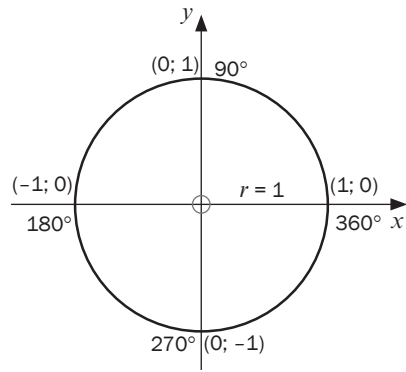

You should **memorise** the special angles, as you will use them often. You will be asked exam questions where you are not allowed to use a calculator, and must show that you have used the special angles.

If you just remember these three diagrams, you can work out all of the special angles.

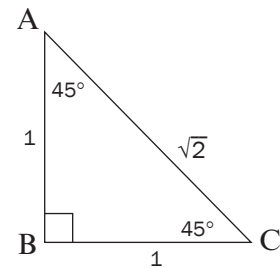
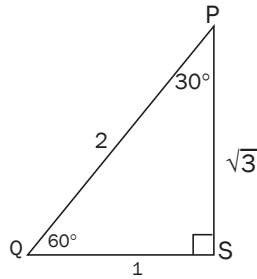

If you find it difficult to remember the diagrams, then learn this summary of the special angles.

θ	30°	45°	60°
sin θ	$\frac{1}{2}$	$\frac{\sqrt{2}}{2}$	$\frac{\sqrt{3}}{2}$
cos θ	$\frac{\sqrt{3}}{2}$	$\frac{\sqrt{2}}{2}$	$\frac{1}{2}$
tan θ	$\frac{\sqrt{3}}{3}$	1	$\sqrt{3}$

You can also use a scientific calculator to find these special angle ratios.

10.6 Using reduction formulae

Look at the angles here. If $\theta < 90^\circ$, it is in the first quadrant, therefore θ is an acute angle.

Therefore

- angle $(180^\circ - \theta)$ in quadrant II
- angle $(180^\circ + \theta)$ in the quadrant III
- angle $(360^\circ - \theta)$ in quadrant IV.

You can work out which trig ratios will be positive and which will be negative, according to the quadrants they are in.

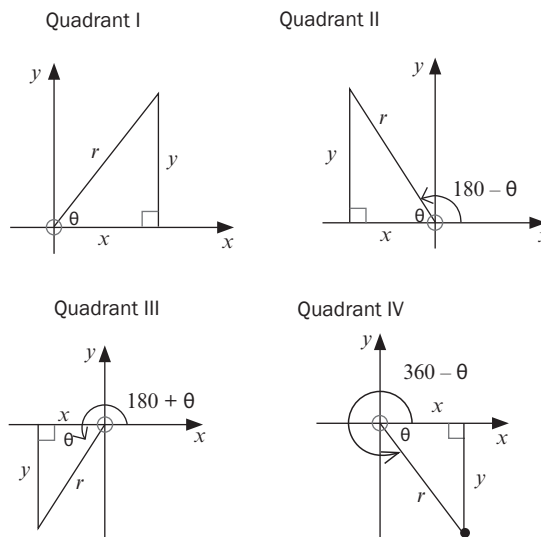

a) Reduction formulae

Quadrant II: $180^\circ - \theta$	Quadrant III: $180^\circ + \theta$	Quadrant IV: $360^\circ - \theta$
$\sin(180^\circ - \theta) = \sin \theta$	$\sin(180^\circ + \theta) = -\sin \theta$	$\sin(360^\circ - \theta) = -\sin \theta$
$\cos(180^\circ - \theta) = -\cos \theta$	$\cos(180^\circ + \theta) = -\cos \theta$	$\cos(360^\circ - \theta) = \cos \theta$
$\tan(180^\circ - \theta) = -\tan \theta$	$\tan(180^\circ + \theta) = \tan \theta$	$\tan(360^\circ - \theta) = -\tan \theta$

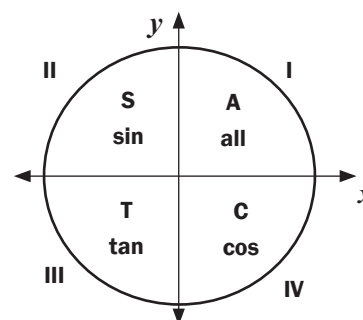

b) Angles greater than 360°

We can add or subtract 360° (or multiples of 360°) and will always end up with an angle in the first revolution. For example, 390° can be written as $(30^\circ + 360^\circ)$, so 390° has the same terminal arm as 30° .

c) Negative angles:

- $(-\theta)$ lies in quadrant IV and is the same as $360^\circ - \theta$.

$$\sin(-\theta) = -\sin \theta \quad \cos(-\theta) = \cos \theta \quad \tan(-\theta) = -\tan \theta$$

- $(\theta - 180)$ lies in the third quadrant

$$\sin(\theta - 180) = -\sin \theta \quad \cos(\theta - 180) = -\cos \theta \quad \tan(\theta - 180) = \tan \theta$$

- $(-\theta - 180)$ lies in the second quadrant

$$\sin(-\theta - 180) = \sin \theta \quad \cos(-\theta - 180) = -\cos \theta \quad \tan(-\theta - 180) = -\tan \theta$$

- $(\theta - 360)$ lies in the first quadrant

$$\sin(\theta - 360) = \sin \theta \quad \cos(\theta - 360) = \cos \theta \quad \tan(\theta - 360) = \tan \theta$$



hint

When you divide, you sometimes need to round off to the closest numbers that are easier to divide.



hint

When you divide, you sometimes need to round off to the closest numbers that are easier to divide.

e.g. 3

$$\sin(360^\circ + \theta) = \sin \theta \quad \cos(360^\circ + \theta) = \cos \theta \quad \tan(360^\circ + \theta) = \tan \theta$$



Activity 4

Without using a calculator, determine the value of:

1. $\cos 150^\circ$
2. $\sin(-45^\circ)$
3. $\tan 480^\circ$

[7]

Solutions

$$\begin{aligned} 1. \quad & \cos 150^\circ \\ &= \cos(180^\circ - 30^\circ) \\ &= -\cos 30^\circ \checkmark \\ &= -\frac{\sqrt{3}}{2} \checkmark (2) \end{aligned}$$

rewrite as $(180 - ?)$
quadrant II, $\cos \theta$ negative
special ratios

$$\begin{aligned} 2. \quad & \sin(-45^\circ) \\ &= -\sin 45^\circ \checkmark \\ &= -\frac{1}{\sqrt{2}} \checkmark (2) \end{aligned}$$

$\sin(-\theta) = -\sin \theta$; quadrant IV, $\sin \theta$ negative
special ratios

$$\begin{aligned} 3. \quad & \tan 480^\circ \\ &= \tan(480^\circ - 360^\circ) \\ &= \tan 120^\circ \checkmark \\ &= \tan(180^\circ - 60^\circ) \\ &= -\tan 60^\circ \checkmark \\ &= -\sqrt{3} \checkmark (3) \end{aligned}$$

write as an angle in the first rotation of 360°

quadrant II, rewrite as $(180 - ?)$
 $\tan \theta$ negative
special ratios

[7]

d) Co-functions

In this right-angled triangle, the sides are a , b and c and $\hat{B} = \theta$.

$A = 90^\circ$ and angles of a triangle are supplementary

$$\therefore \hat{C} = (90^\circ - \theta).$$

Look at the sine and cosine ratios for the triangle:

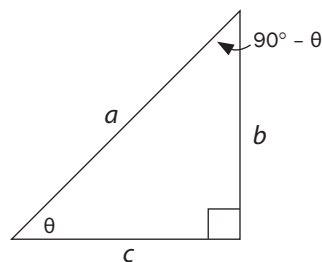

$$\sin \theta = \frac{b}{a} \quad \text{and} \quad \cos(90^\circ - \theta) = \frac{b}{a}$$

$$\therefore \cos(90^\circ - \theta) = \sin \theta$$

$$\cos \theta = \frac{c}{a} \quad \text{and} \quad \sin(90^\circ - \theta) = \frac{c}{a}$$

$$\therefore \sin(90^\circ - \theta) = \cos \theta$$

Trig ratios of angles that add up to 90° , are called **co-functions**.



$\sin(90^\circ - \theta) = \cos \theta$	(quadrant I)
$\sin(90^\circ + \theta) = \cos \theta$	($\sin \theta$ positive in quadrant II)
$\sin(\theta - 90^\circ) = \sin[-(90^\circ - \theta)]$	(common factor of -1)
$= -\sin(90^\circ - \theta)$	($\sin \theta$ negative in quadrant IV)
$= -\cos \theta$	
$\cos(90^\circ - \theta) = \sin \theta$	(quadrant I)
$\cos(90^\circ + \theta) = -\sin \theta$	($\cos \theta$ negative in quadrant II)
$\cos(\theta - 90^\circ) = \cos[-(90^\circ - \theta)]$	(common factor of -1)
$= +\cos(90^\circ - \theta)$	($\cos \theta$ positive in quadrant IV)
$= +\sin \theta$	



Activity 5

Write the trig ratios as the trig ratios of their co-functions:

1. $\sin 50^\circ$
2. $\cos 70^\circ$
3. $\sin 100^\circ$
4. $\cos 140^\circ$

[4]

Solutions

1. $\sin 50^\circ = \sin(90^\circ - 40^\circ) = \cos 40^\circ \checkmark$
2. $\cos 70^\circ = \cos(90^\circ - 20^\circ) = \sin 20^\circ \checkmark$
3. $\sin 100^\circ = \sin(90^\circ + 10^\circ) = \cos 10^\circ \checkmark$
4. $\cos 140^\circ = \cos(90^\circ + 50^\circ) = -\sin 50^\circ \checkmark$

[4]

Summary

Any angle (obtuse or reflex) can be reduced to an acute angle by using:

- Convert negative angles to positive angles
- Reduce angles greater than 360°
- Use reduction formulae
- Use co-functions



Activity 6

Simplify without using a calculator:

$$1. \frac{\sin(180^\circ + x) \cdot \cos 330^\circ \cdot \tan 150^\circ}{\sin x} \quad (4)$$

$$2. \frac{\cos 750^\circ \cdot \tan 315^\circ \cdot \cos(-\theta)}{\cos(360^\circ - \theta) \cdot \sin 300^\circ \cdot \sin(180^\circ - \theta)} \quad (8)$$

$$3. \frac{\tan 480^\circ \cdot \sin 300^\circ \cdot \cos 14^\circ \cdot \sin(-135^\circ)}{\sin 104^\circ \cdot \cos 225^\circ} \quad (9)$$

$$4. \frac{\cos 260^\circ \cdot \cos 170^\circ}{\sin 10^\circ \cdot \sin 190^\circ \cdot \cos 350^\circ} \quad (7)$$

[28]

Solutions

$$1. \frac{\sin(180^\circ + x) \cdot \cos 330^\circ \cdot \tan 150^\circ}{\sin x} \quad \text{reduction formulae in numerator}$$

$$= \frac{(-\sin x)(+\cos 30^\circ)(-\tan 30^\circ)}{\sin x} \quad \text{(use brackets to separate ratios)}$$

$$= \frac{+\sin x \cdot \frac{\sqrt{3}}{2} \cdot \frac{\sqrt{3}}{3}}{\sin x} \quad \text{special angles}$$

$$= \frac{\sqrt{3} \cdot \sqrt{3}}{2 \cdot 3}$$

$$= \frac{3}{6} = \frac{1}{2} \quad (4)$$

$$2. \frac{\cos 750^\circ \cdot \tan 315^\circ \cdot \cos(-\theta)}{\cos(360^\circ - \theta) \cdot \sin 300^\circ \cdot \sin(180^\circ - \theta)} \quad \text{use reduction formulae}$$

$$= \frac{\cos 30^\circ \cdot (-\tan 45^\circ) \cdot \cos \theta}{\cos \theta \cdot (-\sin 60^\circ) \cdot \sin \theta} \quad \text{use special angles}$$

$$= \frac{\frac{\sqrt{3}}{2} \cdot (-1) \cos \theta}{\cos \theta \cdot \left(-\frac{\sqrt{3}}{2}\right) \sin \theta}$$

$$= \frac{-1}{-\sin \theta} = \frac{1}{\sin \theta} \quad (8)$$

$$3. \frac{\tan 480^\circ \cdot \sin 300^\circ \cdot \cos 14^\circ \cdot \sin(-135^\circ)}{\sin 104^\circ \cdot \cos 225^\circ}$$

$$= \frac{\tan 120^\circ \cdot (-\sin 60^\circ) \cdot \cos 14^\circ \cdot \sin 225^\circ}{\sin 76^\circ \cdot (-\cos 45^\circ)}$$

$$= \frac{\cos(180^\circ + 80^\circ) \cdot \cos(180^\circ - 10^\circ)}{\sin 10^\circ \cdot \sin(180^\circ + 10^\circ) \cdot \cos(360^\circ - 10^\circ)}$$

$$= \frac{(-\tan 60^\circ) \cdot (-\sin 60^\circ) \cdot \sin 76^\circ \cdot (-\sin 45^\circ)}{\sin 76^\circ \cdot (-\cos 45^\circ)}$$

$$= \frac{(-\sqrt{3}) \cdot \left(\frac{-\sqrt{3}}{2}\right) \cdot \sin 76^\circ \cdot \left(\frac{-\sqrt{2}}{2}\right)}{\sin 76^\circ \cdot \left(\frac{-\sqrt{2}}{2}\right)}$$

$$= \frac{3}{2} \quad (9)$$

$$4. \frac{\cos 260^\circ \cdot \cos 170^\circ}{\sin 10^\circ \cdot \sin 190^\circ \cdot \cos 350^\circ}$$

$$= \frac{-\cos 80^\circ \cdot (-\cos 10^\circ)}{\sin 10^\circ \cdot (-\sin 10^\circ) \cdot \cos 10^\circ}$$

$$= \frac{(-\sqrt{3}) \cdot \left(\frac{-\sqrt{3}}{2}\right) \cdot \sin 76^\circ \cdot \left(\frac{-\sqrt{2}}{2}\right)}{\sin 76^\circ \cdot \left(\frac{-\sqrt{2}}{2}\right)}$$

$$= \frac{-\sin 10^\circ \cdot (-\cos 10^\circ)}{\sin 10^\circ \cdot (-\sin 10^\circ) \cdot \cos 10^\circ}$$

$$= \frac{-1}{\sin 10^\circ} \quad (7)$$

[28]

10.7 Trigonometric identities

1. $\tan \theta = \frac{\sin \theta}{\cos \theta}$; ($\cos \theta \neq 0$)
(the quotient identity)
2. $\sin^2 \theta + \cos^2 \theta = 1$ (the square identity)
- $\sin^2 \theta = 1 - \cos^2 \theta$
- $\cos^2 \theta = 1 - \sin^2 \theta$



PROOF OF IDENTITIES

Proof of the identities are examinable with the RHS and break it down into its x , y and r values.

$$\begin{aligned} \text{Proof: } \frac{\sin \theta}{\cos \theta} &= \frac{y}{r} \div \frac{x}{r} \\ &= \frac{y}{r} \times \frac{r}{x} \\ &= \frac{y}{x} = \tan \theta \end{aligned}$$

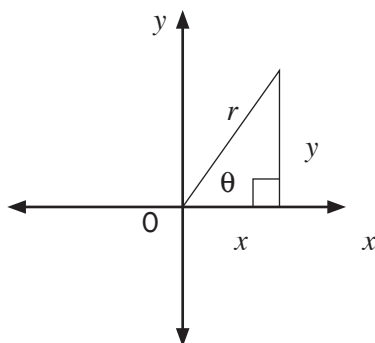

$$\begin{aligned} \text{Proof: } \sin^2 \theta + \cos^2 \theta &= \left(\frac{y}{r}\right)^2 + \left(\frac{x}{r}\right)^2 \\ &= \frac{y^2}{r^2} + \frac{x^2}{r^2} && \text{Use LCD } r^2 \\ &= \frac{x^2 + y^2}{r^2} && x^2 + y^2 = r^2 \text{ (Pythagoras)} \\ &= \frac{r^2}{r^2} = 1 \end{aligned}$$

We can use the identities and the reduction formulae to help us simplify trig expressions.



Activity 7

Simplify the following expressions.

- $\frac{\cos(180^\circ - x) \sin(x - 90^\circ) - 1}{\tan^2(540^\circ + x) \sin(90^\circ + x) \cos(-x)}$ (8)
 - $[\sin(-\theta) + \cos(360^\circ + \theta)][\cos(\theta - 90^\circ) + \cos(180^\circ + \theta)]$ (3)
 - $\cos^2\theta (1 + \tan^2\theta)$ (3)
 - $\frac{1 - \cos^2\theta}{1 - \sin^2\theta}$ (3)
- [17]**

Solutions

$$\begin{aligned}
 1. \quad & \frac{\cos(180^\circ - x) \sin(x - 90^\circ) - 1}{\tan^2(540^\circ + x) \sin(90^\circ + x) \cos(-x)} && \text{– use reduction formulae and co-functions} \\
 & = \frac{(-\cos x) \checkmark (-\cos x) \checkmark -1}{\tan^2(540^\circ - 360^\circ + x) \cos x \checkmark \cdot \cos x \checkmark} && \text{– multiply out numerator and denominator} \\
 & = \frac{\cos^2 x - 1}{\tan^2(180^\circ + x) \cdot \cos^2 x} && \text{– use trig identity format for } \cos^2 x - 1 \\
 & = \frac{-(1 - \cos^2 x)}{\tan^2 x \checkmark \cdot \cos^2 x} && \text{– use trig identities for } 1 - \cos^2 x \text{ and for } \tan x \\
 & = \frac{-\sin^2 x \checkmark}{\frac{\sin^2 x \checkmark}{\cos^2 x} \checkmark \cdot \frac{\cos^2 x}{1}} && \text{– simplify} \\
 & = \frac{-\sin^2 x}{\sin^2 x} = -1 \checkmark && (8)
 \end{aligned}$$

$$\begin{aligned}
 2. \quad & [\sin(-\theta) + \cos(360^\circ + \theta)][\cos(\theta - 90^\circ) + \cos(180^\circ + \theta)] && \text{– reduce to angle } < 90^\circ \\
 & = [-\sin \theta + \cos \theta][\cos(-90^\circ - \theta) + (-\cos \theta)] && \text{– simplify; use co-functions} \\
 & = (-\sin \theta + \cos \theta)(\sin \theta - \cos \theta) && \text{– multiply out using FOIL} \\
 & = -\sin^2 \theta + \sin \theta \cos \theta + \cos \theta \sin \theta - \cos^2 \theta \checkmark \checkmark \\
 & = -(\sin^2 \theta + \cos^2 \theta) + 2 \sin \theta \cos \theta && \text{– use trig identity} \\
 & = -1 + 2 \sin \theta \cos \theta && \text{– use double angle identity} \\
 & = -1 + \sin 2\theta \checkmark && (3)
 \end{aligned}$$

$$\begin{aligned}
 3. \quad & \cos^2 \theta (1 + \tan^2 \theta) && \text{– multiply out the bracket} \\
 & = \cos^2 \theta + \cos^2 \theta \cdot \tan^2 \theta \checkmark && \text{– use trig identity for } \tan \theta \\
 & = \cos^2 \theta + \frac{\cos^2 \theta}{1} \cdot \frac{\sin^2 \theta}{\cos^2 \theta} && \text{– simplify} \\
 & = \cos^2 \theta + \sin^2 \theta \checkmark = 1 \checkmark && \text{– use trig identity } \sin^2 \theta + \cos^2 \theta = 1 \quad (3)
 \end{aligned}$$

$$\begin{aligned}
 4. \quad & \frac{1 - \cos^2 \theta}{1 - \sin^2 \theta} && \text{– use trig identity } \sin^2 \theta + \cos^2 \theta = 1 \\
 & = \frac{\sin^2 \theta \checkmark}{\cos^2 \theta \checkmark} && \text{– use trig identity for } \tan \theta \\
 & = \tan^2 \theta \checkmark && (3)
 \end{aligned}$$

[17]

10.8 More trig identities

You need to be able to use all the information you have about trig ratios and ways to simplify them in order to solve more complicated trig identities.



Activity 8

Prove the following identities:

$$1. \quad \sin x \cdot \tan x + \cos x = \frac{1}{\cos x} \quad (4)$$

$$2. \quad (\sin x + \tan x) \left(\frac{\sin x}{1 + \cos x} \right) = \sin x \cdot \tan x \quad (7)$$

$$3. \quad \frac{1}{\cos x} = \frac{\cos x}{1 + \sin x} + \tan x \quad (6)$$

$$4. \quad \frac{1}{\tan x} + \tan x = \frac{\tan x}{\sin^2 x} \quad (5)$$

[22]

Solutions

1. LHS: $\sin x \cdot \tan x + \cos x$

$$= \sin x \cdot \frac{\sin x}{\cos x} + \cos x \checkmark + \cos x$$

$$= \frac{\sin^2 x}{\cos x} + \frac{\cos x}{1}$$

$$= \frac{\sin^2 x + \cos^2 x \checkmark}{\cos x \checkmark} = \frac{1}{\cos x} \checkmark = \text{RHS (4)}$$

$$\therefore \sin x \cdot \tan x + \cos x = \frac{1}{\cos x} \quad (4)$$

2. LHS: $(\sin x + \tan x) \left(\frac{\sin x}{1 + \cos x} \right)$

$$= \left(\sin x + \frac{\sin x}{\cos x} \checkmark \right) \left(\frac{\sin x}{1 + \cos x} \right)$$

$$= \left(\frac{\sin x \cos x + \sin x \checkmark}{\cos x \checkmark} \right) \left(\frac{\sin x}{1 + \cos x} \right)$$

$$= \left(\frac{\sin x (\cos x + 1) \checkmark}{\cos x} \right) \left(\frac{\sin x}{1 + \cos x} \right)$$

$$= \frac{\sin^2 x}{\cos x} \checkmark (7)$$

$$\therefore \text{LHS} = \text{RHS} \quad (7)$$

RHS: $\sin x \cdot \tan x$

$$= \sin x \cdot \frac{\sin x}{\cos x} \checkmark$$

$$= \frac{\sin^2 x}{\cos x} \checkmark$$

3. RHS: $\frac{\cos x}{1 + \sin x} + \tan x$

$$= \frac{\cos x}{1 + \sin x} + \frac{\sin x}{\cos x} \checkmark$$

$$= \frac{\cos^2 x + \sin x (1 + \sin x) \checkmark}{\cos x (1 + \sin x) \checkmark}$$

$$= \frac{\cos^2 x + \sin x + \sin^2 x \checkmark}{\cos x (1 + \sin x)}$$

trig identity: $\cos^2 x + \sin^2 x = 1$

$$= \frac{1 + \sin x \checkmark}{\cos x (1 + \sin x)}$$

$$= \frac{1}{\cos x} \checkmark = \text{LHS}$$

$$\therefore \frac{1}{\cos x} = \frac{\cos x}{1 + \sin x} + \tan x \quad (6)$$



Hints for solving trig identities:

- Choose either the **left-hand side** or the **right-hand side** and simplify it to look like the other side.
- If both sides look difficult, you can try to simplify on both sides until you reach a point where both sides are the same.
- It is usually helpful to write $\tan \theta$ as $\frac{\sin \theta}{\cos \theta}$.
- Sometimes you need to simplify $\frac{\sin \theta}{\cos \theta}$ to $\tan \theta$.
- If you have $\sin^2 x$ or $\cos^2 x$ with $+1$ or -1 , use the squares identities ($\sin^2 \theta + \cos^2 \theta = 1$).
- Find a common denominator when fractions are added or subtracted.
- Factorise if necessary – specify with examples i.e. common factor, DOPS, Trinomial, sum/diff of two cubes

$$4. \frac{1}{\tan x} + \tan x = \frac{\tan x}{\sin^2 x}$$

$$\begin{aligned} \text{LHS: } \frac{1}{\tan x} + \tan x & \quad \text{RHS: } \frac{\tan x}{\sin^2 x} \\ &= \frac{1}{\frac{\sin x}{\cos x}} + \frac{\sin x}{\cos x} \checkmark &= \frac{\sin x}{\cos x} \checkmark \cdot \frac{1}{\sin^2 x} \\ &= \frac{\cos x}{\sin x} \checkmark + \frac{\sin x}{\cos x} &= \frac{1}{\sin x \cdot \cos x} \\ &= \frac{\cos^2 x + \sin^2 x}{\sin x \cdot \cos x} \checkmark \\ &= \frac{1}{\sin x \cdot \cos x} \end{aligned}$$

$$\therefore \text{LHS} = \text{RHS}$$

(5)
[22]

10.9 Solving trigonometric equations

To solve a trig equation where the angle is unknown, you need to find all the possible values of the angle.

For example, if $\sin \theta = \frac{1}{2}$, we know that θ could be 30° . However, there are other values for θ in the other quadrants. Have a look at the graph for \sin

$$\theta = \frac{1}{2}, \theta \in [-360^\circ; 720^\circ].$$

There are six values for θ between -360° and 720° .

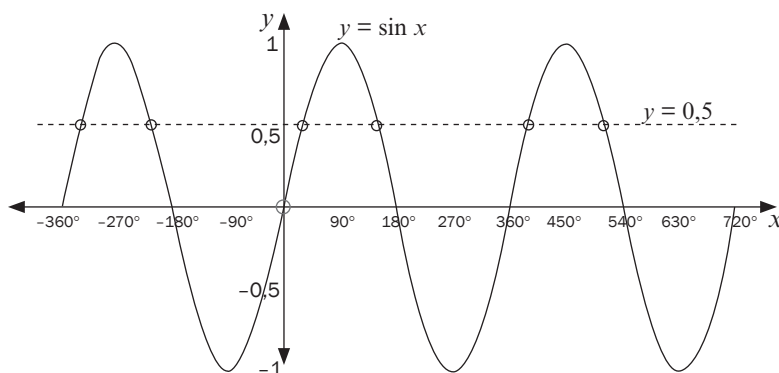

If 30° is our reference angle in quadrant I.

In quadrant II: $\sin(180^\circ - 30^\circ) = \sin 30^\circ = \frac{1}{2}$

So θ is 150°

In quadrant III and IV, the sine ratio is negative, so there is no solution for θ .

The angle could be greater than 360° .

In quadrant I: $\sin(360^\circ + 30^\circ) = \sin 30^\circ = \frac{1}{2}$

So θ is 390°

In quadrant II: $\sin(540^\circ - 30^\circ) = \sin((540^\circ - 360^\circ) - 30^\circ)$
 $= \sin(180^\circ - 30^\circ) = \sin 30^\circ = \frac{1}{2}$

So θ is 510°

You can also work out that $\theta = -210^\circ$ or $\theta = -330^\circ$

You do not need to draw a graph to solve these equations.



A method to find the general solution of trig equations:

1. Isolate the trig function on one side of the equation.
2. Determine the reference angle: put the **positive** number for the angle in the calculator and press the trig key and the inverse key:
shift sin / shift cos / shift tan.
 Use special angles if the question does not allow you to use a calculator.
3. For $\sin x$ and $\cos x$, place the reference angle in the two possible quadrants where they are positive or negative (according to the question). The period of the sine and cosine graphs is 360° , so add $k \cdot 360^\circ$ to each solution. Always put $k \in \mathbb{Z}$.
4. For $\tan x$, place the reference angle in one correct quadrant where it is positive or negative (according to the question). The period of the tan graph is 180° , so add $k \cdot 180^\circ$. Always put $k \in \mathbb{Z}$.
5. If x must be solved for a given interval:
 - a) Find the general solution
 - b) Substitute k with $-1; 0; 1; 2$, etc. to find the solutions in the correct interval.

e.g. 4

1. Solve for x : $\sin x = 0,7$ [On your calculator, press: $\sin^{-1} 0,7 =$
The calculator answer is $44,42\dots\dots^\circ$

We call this the **reference angle**, as it is not the only solution to the equation.

$\sin x$ is positive, so angle x must be in quadrant I or quadrant II in the first revolution.

In quadrant I: $x = 44,42\dots\dots^\circ$

AND

In quadrant II: $x = 180^\circ - 44,42\dots\dots^\circ = 135,57\dots\dots^\circ$

The period of the sin graph is 360° , so the other points of intersection occur 360° to the right or left of these solutions.

We add k revolutions to the two angles in the first revolution.

k is an integer ($\dots -1; 0; 1; \dots$). We call this **the general solution** of the equation.

So we can say the solution to **$\sin x = 0,7$** is

$$x = 44,42^\circ + k360^\circ \text{ or } x = 135,57^\circ + k360^\circ; k \in \mathbb{Z}.$$

(Correct to two decimal place)

2. Solve for x : $\sin x = -0,7$

This time, place the reference angle in quadrants III and IV ($\sin x$ is negative)

$$x = 180^\circ + 44,42\dots\dots^\circ + k360^\circ \text{ or } x = 360^\circ - 44,42\dots\dots^\circ + k360^\circ; k \in \mathbb{Z}$$

$$x = 224,42^\circ + k360^\circ \text{ or } x = 315,57^\circ + k360^\circ; k \in \mathbb{Z}$$

(Correct to two decimal place)

3. Solve for x : $\cos x = -0,7$ Reference angle = $134,427\dots\dots^\circ$

$\cos x$ is negative in quadrants II and III.

$$x = 360^\circ - 134,43^\circ = 225,57^\circ$$

$$x = 134,43^\circ + k360^\circ \quad \text{or} \quad x = 225,57^\circ + k360^\circ; k \in \mathbb{Z}$$

(Correct to two decimal place)

4. Solve for x : $\cos x = 0,7$ Reference angle = $45,57\dots\dots^\circ$

This time, place the reference angle in quadrants I and IV where $\cos x$ is positive:

$$x = 45,57\dots\dots^\circ + k360^\circ \quad \text{or} \quad x = 360^\circ - 45,57\dots\dots^\circ + k360^\circ$$

$$x = 45,57^\circ + k360^\circ \quad \text{or} \quad x = 314,43^\circ + k360^\circ; k \in \mathbb{Z}.$$

(Correct to two decimal place)

5. Solve for x : $\tan x = 0,7$

$\tan x$ is positive in quadrants I and III.

Reference angle = $34,99^\circ$ (correct to 2 dec places)

$$x = 34,99\dots\dots^\circ \quad \text{or} \quad 180^\circ + 34,99\dots\dots^\circ = 214,99\dots\dots^\circ$$

Now the period of the tan graph is 180° , so the other points of intersection occur 180° to the right or left of the solutions.

$$x = 34,99^\circ + k180^\circ; k \in \mathbb{Z}$$

(Correct to two decimal place)

6. Solve for x : $\tan x = -0,7$

$\tan x$ is negative in quadrants II and IV.

The reference angle is $-34,99\dots\dots^\circ$

$$180^\circ - 34,99\dots\dots^\circ = 145,01\dots\dots^\circ$$

$$x = 145,01^\circ + k180^\circ; k \in \mathbb{Z}.$$



You do not need to write down the solution of 215° .

This solution is already there because

$$34,99^\circ + (1)180^\circ = 215^\circ$$



Activity 9

- If $\cos 20^\circ = p$, determine the following ratios in terms of p :
 - $\cos 380^\circ$
 - $\sin 110^\circ$
 - $\sin 200^\circ$
- Determine the general solution for x in the following equations:
 - $5 \sin x = \cos 320^\circ$ (correct to 2 decimal places)
 - $3 \tan x + \sqrt{3} = 0$ (without using a calculator)
 - $\frac{\tan x - 1}{2} = -3$ (correct to one decimal place)
- Determine x for $x \in [-180^\circ; 180^\circ]$ if $2 + \cos(2x - 10^\circ) = 2,537$

[22]

Solutions

1. $\cos 20^\circ = \frac{p}{1}$ so $x = p$ and $r = 1$

By Pythagoras, $y^2 = r^2 - x^2$

$$y^2 = 1^2 - p^2 = 1 - p^2$$

$$y = \sqrt{1 - p^2} \quad \text{first quadrant, so } y \text{ is positive}$$

a) $\cos 380^\circ = \cos(360^\circ + 20^\circ) = \cos 20^\circ \checkmark = p \checkmark (2)$

b) $\sin 110^\circ$ reduction formula

$$= \sin(180^\circ - 70^\circ)$$

$$= \sin 70^\circ \checkmark \quad \text{co-function}$$

$$= \sin(90^\circ - 20^\circ)$$

$$= \cos 20^\circ \checkmark = p \checkmark (3)$$

c) $\sin 200^\circ = \sin(180^\circ + 20^\circ)$

$$= -\sin 20^\circ \checkmark$$

$$= \frac{-\sqrt{1 - p^2}}{1} = -\sqrt{1 - p^2} (1) \quad (6)$$

2. a) $5 \sin x = \cos 320^\circ \checkmark$

$$5 \sin x = 0,766044$$

$$\sin x = 0,15320... \checkmark$$

$$\text{Ref angle} = 8,81^\circ$$

$$x = 8,81^\circ + k360^\circ \text{ OR } x = 180^\circ - 8,81^\circ + k360^\circ \checkmark$$

$$x = 171,19^\circ + k360^\circ \checkmark k \in \mathbb{Z} (4)$$

b) $3 \tan x + \sqrt{3} = 0$

$$3 \tan x = -\sqrt{3}$$

$$\tan x = \frac{-\sqrt{3}}{3} \checkmark \quad [\text{special angle: } \tan 30^\circ \tan 30^\circ = \frac{\sqrt{3}}{3}]$$

$$\text{Ref angle} = 30^\circ$$

$$x = 180^\circ - 30^\circ + k180^\circ \checkmark$$

$$x = 150^\circ + k180^\circ \checkmark k \in \mathbb{Z} (3)$$

Calculator keys:

$$\cos 320 =$$

$$\div 5 =$$

$$\text{SHIFT sin ANS} =$$

c) $\frac{\tan x - 1}{2} = -3$ multiply both sides by 2

$$\tan x - 1 = -6$$

$$\tan x = -5 \checkmark \quad \text{reference angle is } 78,69\dots^\circ$$

$$\therefore x = 180^\circ - 78,69\dots^\circ + k180^\circ \checkmark$$

$$x = 101,31^\circ + k180^\circ; k \in \mathbb{Z} \checkmark (3) \quad (10)$$

3. $2 + \cos(2x - 10^\circ) = 2,537$

$$\cos(2x - 10^\circ) = 0,537$$

$$\text{Ref angle} = 57,52\dots^\circ$$

$$2x - 10^\circ = 57,52\dots^\circ + k360^\circ \text{ or } 2x - 10^\circ = 360^\circ - 57,52^\circ + k360^\circ$$

[solve equations]

$$2x = 67,52\dots^\circ + k360^\circ \text{ or } 2x = 312,48\dots^\circ + k360^\circ \checkmark$$

[divide all terms on both sides by 2]

$$x = 33,76^\circ + k180^\circ \text{ or } x = 156,24^\circ + k180^\circ \checkmark k \in \mathbb{Z}$$

$$x \in [-180^\circ; 180^\circ]$$

$$\text{So for } k = -1: x = 33,76^\circ - 180^\circ = -146,24^\circ \text{ or } x = 156,24^\circ - 180^\circ = -23,76^\circ \checkmark$$

$$\text{For } k = 0: x = 33,76^\circ \quad \text{or } x = 156,24^\circ \checkmark$$

(For $k = 1$, x will be $> 180^\circ$, so it is too big)

$$\text{Solution: } x \in \{-146,24^\circ; -23,76^\circ; 33,76^\circ; 156,24^\circ\} \checkmark \checkmark \quad (6)$$

[22]

10.10 More solving trig equations using identities



• $a \sin \theta = b \cos \theta$: single sin and cos function with the same angle

- 1) Divide by the cos function
- 2) Change $\sin \frac{\theta}{\cos \theta}$ to $\tan \theta$

e.g. 5

Solve for x (give general solution) and round off your answer to 2 decimal places.

1. $3 \sin x = 4 \cos x$
2. $4 \cos^2 x + 4 \sin x \cos x + 1 = 0$

[6]

Solutions

1. $3 \sin x = 4 \cos x$ Divide both sides by $\cos x$ to create $\tan x$ on LHS

$$\frac{3 \sin x}{\cos x} = \frac{4 \cos x}{\cos x} \checkmark \quad \text{Trig identity for } \tan x$$

$$3 \tan x = 4$$

$$\tan x = \frac{3}{4} \checkmark$$

$$\text{Ref angle} = 53,13^\circ$$

$$x = 53,13^\circ + k180^\circ \quad k \in \mathbb{Z} \checkmark (3)$$

2. $4 \cos^2 x + 4 \sin x \cos x + 1 = 0$ use $1 = \sin^2 x + \cos^2 x$

$$4 \cos^2 x + 4 \sin x \cos x + (\sin^2 x + \cos^2 x) \checkmark = 0$$

$$5 \cos^2 x + 4 \sin x \cos x + \sin^2 x = 0$$

$$(5 \cos x + \sin x)(\cos x + \sin x) = 0$$

$$5 \cos x + \sin x = 0 \quad \text{or}$$

$$\frac{5 \cos x}{\cos x} = \frac{-\sin x}{\cos x} \quad \text{or}$$

$$5 = -\tan x \therefore \tan x = -5$$

$$\text{Reference angle} = 78,69^\circ$$

$$x = 180^\circ - 78,69^\circ + k180^\circ \quad \text{or}$$

$$\therefore x = 101,3^\circ + k180^\circ \checkmark$$

$$\cos x + \sin x = 0$$

$$\frac{\cos x}{\cos x} = \frac{-\sin x}{\cos x}$$

$$1 = -\tan x \therefore \tan x = -1$$

$$\text{Reference angle} = -45^\circ$$

$$\therefore x = 180^\circ - 45^\circ + k180^\circ$$

$$\therefore x = 135^\circ + k180^\circ \checkmark k \in \mathbb{Z} (3)$$

[6]



• $a \sin \theta = b \cos \beta$: single sin and cos function with the different angles

1. Use co-functions to get the same function i.e. change the sin function to a cos function or the cos function to a sin function.

2. If $\sin \theta = \sin \beta$, we equate the angles then $\theta = \beta$ and $\theta = 180^\circ - \beta$.

If $\cos \theta = \cos \beta$ we equate the angles then $\theta = \beta$ and $\theta = 360^\circ - \beta$

e.g. 6

Solve for x (give general solution) and round off your answer to 2 decimal places.

$$\sin(x + 20^\circ) = \cos 3x$$

[7]

Solution

$$\sin(x + 20^\circ) = \cos 3x$$

Use co-functions

$$\sin(x + 20^\circ) = \sin(90^\circ - 3x) \checkmark$$

Choose one angle to be the reference angle

$$\text{Ref angle} = (90^\circ - 3x)$$

$$x + 20^\circ = 90^\circ - 3x + k360^\circ \checkmark$$

$$\text{or } x + 20^\circ = 180^\circ - (90^\circ - 3x) + k360^\circ \checkmark$$

$$4x = 70^\circ + k360^\circ \checkmark$$

$$x + 20^\circ = 180^\circ - 90^\circ + 3x + k360^\circ$$

$$x = 17,5^\circ + k90^\circ \checkmark$$

$$-2x = 70^\circ + k360^\circ \checkmark$$

$$x = -35^\circ - k180^\circ \checkmark \quad k \in \mathbb{Z}$$

[7]

e.g. 7

- $\sin^2 A - \sin A \cos A = 0$
- $\cos^2 A - 2 \cos A - 3 = 0$
- $\cos^2 x + 3 \sin x = -3$

[16]



Trigonometric equations that leads to quadratic equations

Solutions

$$1. \sin^2 A - \sin A \cos A = 0$$

$$\sin A(\sin A - \cos A) = 0 \dots \dots \checkmark \dots \dots \text{factorise by means of a HCF}$$

$$\therefore \sin A = 0 \text{ or } \sin A - \cos A = 0 \checkmark$$

$$\therefore \sin A = 0 \text{ or } \sin A = \cos A$$

$$\therefore A = 0^\circ + 360^\circ n \checkmark \text{ or } \tan A = 1 \checkmark$$

$$\therefore A = 45^\circ + 180^\circ n \dots \dots n \in \mathbb{Z} \checkmark \quad (5)$$

$$2. \cos^2 A - 2 \cos A - 3 = 0$$

$$(\cos A + 1)(\cos A - 3) = 0 \checkmark$$

$$\therefore \cos A + 1 = 0 \checkmark \text{ or } \cos A - 3 = 0$$

$$\therefore \cos A = -1 \checkmark \text{ or } \cos A = 3 \checkmark$$

$$\therefore A = -180^\circ + 360^\circ n \dots \dots n \in \mathbb{Z}$$

$$\text{if } \cos A = 3 \dots \dots \text{no solution } \checkmark \quad (5)$$

$$3. \cos^2 x + 3 \sin x = -3$$

Use $\cos^2 x = 1 - \sin^2 x$ to make a quadratic equation in $\sin x$

$$1 - \sin^2 x + 3 \sin x + 3 = 0$$

$$-\sin^2 x + 3 \sin x + 4 = 0$$

$$\sin^2 x - 3 \sin x - 4 = 0 \checkmark$$

$$(\sin x - 4)(\sin x + 1) = 0 \checkmark$$

$$\sin x - 4 = 0 \quad \text{or} \quad \sin x + 1 = 0$$

$$\sin x = 4 \checkmark \quad \sin x = -1 \checkmark$$

$$\text{No solution } \checkmark$$

$$\text{ref angle} = -90^\circ$$

$$(-1 \leq \sin x \leq 1) \quad x = -90^\circ + k360^\circ \quad \text{or} \quad x = 360^\circ - 90^\circ + k360^\circ$$

$$x = 270^\circ + k360^\circ \checkmark$$

(6)

[16]

10.11 Compound and double angle identities

$$\sin(20^\circ + 30^\circ) \neq \sin 20^\circ + \sin 30^\circ$$

When two angles are added or subtracted to form a new angle, then a **compound** or a **double** angle is formed.

Sketch 1

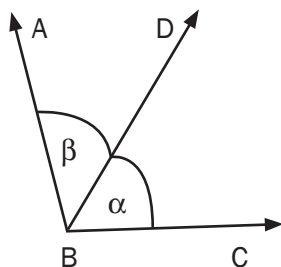

Sketch 2

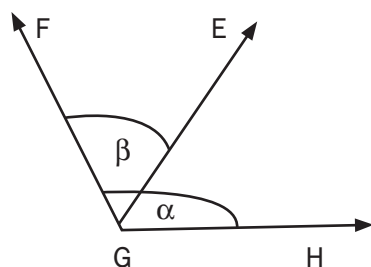

Sketch 3

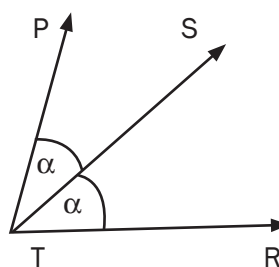

Sketch 1 : The compound angle \widehat{ABC} is equal to the sum of α and β

eg. $75^\circ = 45^\circ + 30^\circ$

Sketch 2 : The compound angle \widehat{EGH} is equal to the difference between α and β

eg. $15^\circ = 60^\circ - 45^\circ$ or $15^\circ = 45^\circ - 30^\circ$

Sketch 3 : The double angle \widehat{PTR} is equal to the sum of α and α

eg. $45^\circ = 22,5^\circ + 22,5^\circ$

NOTE:

$\sin(\alpha + \beta) \neq \sin\alpha + \sin\beta$ and
 $\cos(\alpha - \beta) \neq \cos\alpha - \cos\beta$

Using the same methods as we did to establish the reduction formulae, we can also establish the compound angle identities.

Given any angles α and β , we can find the values of the sine and cosine ratios of the angles $\alpha + \beta$, $\alpha - \beta$ and 2α .



$$\sin(\alpha + \beta) = \sin\alpha \cos\beta + \cos\alpha \sin\beta$$

$$\sin(\alpha - \beta) = \sin\alpha \cos\beta - \cos\alpha \sin\beta$$

$$\cos(\alpha + \beta) = \cos\alpha \cos\beta - \sin\alpha \sin\beta$$

$$\cos(\alpha - \beta) = \cos\alpha \cos\beta + \sin\alpha \sin\beta$$

$$\sin 2\alpha = 2\sin\alpha \cos\alpha$$

$$\cos 2\alpha = \cos^2\alpha - \sin^2\alpha$$

$$= 2\cos^2\alpha - 1$$

$$= 1 - 2\sin^2\alpha$$

These formulae are provided on the **information sheet** in the final exam.

You should **learn** these formulae, as you will use them often.

Accept:

$\cos(\alpha - \beta) = \cos\alpha \cdot \cos\beta + \sin\alpha \cdot \sin\beta$,
and derive the other compound angle identities



These are examinable, learn them well.

Proof:

$$\begin{aligned}\cos(\alpha + \beta) &= \cos[\alpha - (-\beta)] = \cos\alpha \cdot \cos(-\beta) + \sin\alpha \cdot \sin(-\beta) \\ &= \cos\alpha \cdot \cos\beta + \sin\alpha \cdot (-\sin\beta) \\ &= \cos\alpha \cdot \cos\beta - \sin\alpha \cdot \sin\beta\end{aligned}$$

Proof:

$$\begin{aligned}\sin(\alpha + \beta) &= \cos[90^\circ - (\alpha + \beta)] = \cos[90^\circ - \alpha - \beta] = \cos[(90^\circ - \alpha) - \beta] \\ &= \cos(90^\circ - \alpha) \cdot \cos\beta + \sin(90^\circ - \alpha) \cdot \sin\beta \\ &= \sin\alpha \cdot \cos\beta + \cos\alpha \cdot \sin\beta\end{aligned}$$

Proof:

$$\begin{aligned}\sin(\alpha - \beta) &= \cos[90^\circ - (\alpha - \beta)] = \cos[90^\circ - \alpha + \beta] = \cos[(90^\circ + \beta) - \alpha] \\ &= \cos(90^\circ + \beta) \cdot \cos\alpha + \sin(90^\circ + \beta) \cdot \sin\alpha \\ &= -\sin\beta \cdot \cos\alpha + \cos\beta \cdot \sin\alpha \\ &= \sin\alpha \cdot \cos\beta - \cos\alpha \cdot \sin\beta\end{aligned}$$



Simplify without the use of a calculator:

1. $\cos 70^\circ \cos 10^\circ + \cos 20^\circ \cos 80^\circ$
2. $2 \sin 15^\circ \cos 15^\circ$
3. $\sin 15^\circ$

[10]

Solutions

$$\begin{aligned}
 1. \quad & \cos 70^\circ \cos 10^\circ + \cos 20^\circ \cos 80^\circ \\
 &= \cos 70^\circ \cos 10^\circ + \sin 70^\circ \sin 10^\circ \\
 &= \cos(70^\circ - 10^\circ) \checkmark \\
 &= \cos 60^\circ \checkmark \\
 &= \frac{1}{2} \checkmark
 \end{aligned}$$

(3)

$$\begin{aligned}
 2. \quad & 2 \sin 15^\circ \cos 15^\circ \\
 &= \sin 2(15^\circ) \checkmark \\
 &= \sin 30^\circ \checkmark \\
 &= \frac{1}{2} \checkmark
 \end{aligned}$$

(3)

$$\begin{aligned}
 3. \quad & \sin 15^\circ \\
 &= \sin (45^\circ - 30^\circ) \\
 &= \sin 45^\circ \cdot \cos 30^\circ - \cos 45^\circ \cdot \sin 30^\circ \\
 &= \frac{1}{\sqrt{2}} \times \frac{\sqrt{3}}{2} - \frac{1}{\sqrt{2}} \times \frac{1}{2} \checkmark \checkmark \\
 &= \frac{\sqrt{3}}{2\sqrt{2}} - \frac{1}{2\sqrt{2}} \\
 &= \frac{\sqrt{3}-1}{2\sqrt{2}} \checkmark \times \frac{\sqrt{2}}{\sqrt{2}} \\
 &= \frac{\sqrt{2}(\sqrt{3}-1)}{4} \checkmark
 \end{aligned}$$

(4)

[10]



Activity 10

Do NOT use a calculator to answer this question. Show ALL calculations. Prove that:

$$1. \cos 75^\circ = \frac{\sqrt{2}(\sqrt{3}-1)}{4} \quad (5)$$

$$2. \text{ Prove that } \cos(90^\circ - 2x) \cdot \tan(180^\circ + x) + \sin^2(360^\circ - x) = 3\sin^2 x \quad (7)$$

$$3. \text{ Prove that } (\tan x - 1)(\sin 2x - 2\cos^2 x) = 2(1 - 2\sin x \cos x) \quad (7)$$

[19]

Solutions

$$\begin{aligned}
 1. \text{ LHS} &= \cos 75^\circ = \cos(45^\circ + 30^\circ) \checkmark \\
 &= \cos 45^\circ \cdot \cos 30^\circ - \sin 45^\circ \cdot \sin 30^\circ \checkmark \\
 &= \frac{\sqrt{2}}{2} \cdot \frac{\sqrt{3}}{2} - \frac{\sqrt{2}}{2} \cdot \frac{1}{2} \checkmark \checkmark \\
 &= \frac{\sqrt{2} \cdot \sqrt{3}}{4} - \frac{\sqrt{2}}{4} \\
 &= \frac{\sqrt{2}(\sqrt{3}-1)}{4} \checkmark = \text{RHS} \quad (5)
 \end{aligned}$$

$$\begin{aligned}
 2. \text{ LHS} &= \cos(90^\circ - 2x) \cdot \tan(180^\circ + x) + \sin^2(360^\circ - x) \quad \text{co-functions and reductions} \\
 &= \sin 2x \checkmark \cdot \tan x \checkmark + \sin^2 x \checkmark \quad \text{double angle for } \sin 2x \\
 &= 2\sin x \cdot \cos x \checkmark \cdot \frac{\sin x}{\cos x} \checkmark + \sin^2 x \quad \text{trig identity for } \tan x \\
 &= 2\sin^2 x + \sin^2 x \checkmark \quad \text{simplify} \\
 &= 3\sin^2 x \checkmark = \text{RHS} \quad (7)
 \end{aligned}$$

3. There are several ways to prove this. Here is one solution.

$$\begin{aligned}
 \text{LHS} &= (\tan x - 1)(\sin 2x - 2\cos^2 x) \\
 &= \left(\frac{\sin x}{\cos x} \checkmark - 1\right)(2\sin x \cdot \cos x \checkmark - 2\cos^2 x) \quad \text{double angle identity for } \sin 2x \\
 &= 2\sin^2 x - 2\sin x \cdot \cos x - 2\sin x \cdot \cos x + 2\cos^2 x \checkmark \checkmark \quad \text{multiply out} \\
 &= 2\sin^2 x - 4\sin x \cos x + 2\cos^2 x \checkmark \\
 &= 2(\sin^2 x - 2\sin x \cdot \cos x + \cos^2 x) \checkmark \quad \text{trig identity } \sin^2 x + \cos^2 x = 1 \\
 &= 2(1 - 2\sin x \cdot \cos x) \checkmark = \text{RHS} \quad (7)
 \end{aligned}$$

[19]



Activity 11

Determine the general solution for x in the following:

a) $\sin 2x \cdot \cos 10^\circ - \cos 2x \cdot \sin 10^\circ = \cos 3x$ (8)

b) $\cos^2 x = 3 \sin 2x$ (11)

c) $2\sin x = \sin(x + 30^\circ)$ (5)

[24]

Solutions

a) $\sin 2x \cdot \cos 10^\circ - \cos 2x \cdot \sin 10^\circ = \cos 3x$ use compound angle identity

$$\therefore \sin(2x - 10^\circ) \checkmark = \cos 3x \quad \text{use co-functions}$$

$$\therefore \sin(2x - 10^\circ) = \sin(90^\circ - 3x) \checkmark$$

$$\therefore 2x - 10^\circ = 90^\circ - 3x + k360^\circ \checkmark \text{ or } 2x - 10^\circ = 180^\circ - (90^\circ - 3x) + k360^\circ \checkmark k \in \mathbb{Z}$$

$$\therefore 5x = 100^\circ + k360^\circ \checkmark \quad 2x - 10^\circ = 90^\circ + 3x + k360^\circ$$

$$\therefore x = 20^\circ + k72^\circ \checkmark \quad -x = 100 + k360^\circ \checkmark$$

$$x = -100 - k360 \checkmark k \in \mathbb{Z} \quad (8)$$

b) $\cos^2 x = 3 \sin 2x$ use double angles for $\sin 2x$

$$\cos^2 x = 3(2 \sin x \cdot \cos x) \checkmark \quad \text{make LHS} = 0$$

$$\cos^2 x - 3(2 \sin x \cdot \cos x) = 0 \quad \text{multiply out}$$

$$\cos^2 x - 6 \sin x \cdot \cos x = 0 \checkmark \quad \text{common factor}$$

$$\cos x (\cos x - 6 \sin x) \checkmark = 0$$

$$\therefore \cos x = 0 \checkmark \text{ or } \cos x - 6 \sin x = 0 \checkmark$$

$$\cos x = 0 \text{ or } \frac{\cos x}{\cos x} = \frac{6 \sin x}{\cos x}$$

$$\cos x = 0 \text{ or } 1 = 6 \tan x$$

$$\cos x = 0 \quad \text{or} \quad \tan x = \frac{1}{6} \checkmark$$

$$\text{Reference angle} = 90^\circ \quad \text{or} \quad \text{reference angle} = 9,46^\circ$$

$$\therefore x = 90^\circ + k360^\circ \checkmark \text{ or } x = 360^\circ - 90^\circ + k360^\circ \text{ or } x = 9,46^\circ + k180^\circ \checkmark k \in \mathbb{Z}$$

$$x = 270^\circ + k360^\circ \checkmark \text{ or } x = 180^\circ + 9,46^\circ + k360^\circ \checkmark k \in \mathbb{Z} \\ = 189,46^\circ + k360^\circ \checkmark k \in \mathbb{Z} \quad (11)$$

c) $2 \sin x = \sin(x + 30^\circ)$

$$2 \sin x = \sin x \cdot \cos 30^\circ + \cos x \cdot \sin 30^\circ \checkmark$$

$$2 \sin x = \sin x \cdot \frac{\sqrt{3}}{2} + \cos x \cdot \frac{1}{2} \checkmark \quad \text{multiply by 2}$$

$$4 \sin x = \sqrt{3} \sin x + \cos x \quad \text{divide by } \cos x$$

$$4 \tan x = \sqrt{3} \tan x + 1$$

$$4 \tan x - \sqrt{3} \tan x = 1 \checkmark$$

$$\tan x = \frac{1}{4 - \sqrt{3}} \checkmark$$

$$x = 23,79^\circ + k180^\circ; k \in \mathbb{Z} \checkmark \quad (5)$$

[24]

10.12 Determining x for which the identity is undefined



- $\frac{\text{any number}}{0}$ is undefined.
Therefore if the denominator of an identity = 0, then the identity is undefined
- $y = \tan x$ is undefined for certain value of x .
Therefore if a tan function is in an identity then the identity is undefined where the tan function is undefined.

e.g. 9

For which values of x is this identity undefined? $\frac{1}{\tan x} + \tan x = \frac{\tan x}{\sin^2 x}$

[4]

Solution

$\frac{1}{\tan x} + \tan x = \frac{\tan x}{\sin^2 x}$ is undefined if $\tan x = 0$ or if $\sin^2 x = 0$ or if $\tan x$ is undefined

[division by 0 is undefined]

$$\begin{array}{lll} \text{if } \tan x = 0 & \text{OR} & \text{if } \sin^2 x = 0 & \text{OR} & \tan x \text{ is undefined} \\ x = 0^\circ + k180^\circ \checkmark & \text{OR} & \sin x = 0 \checkmark \checkmark & & x = 90^\circ + k180^\circ \checkmark (4) \\ x = 0^\circ + k360^\circ & \text{OR} & x = 180^\circ + k360^\circ & & \end{array}$$

So the identity is undefined for $x = 0^\circ + k360^\circ$ or $x = 180^\circ + k360^\circ$
or $x = 90^\circ + k180^\circ$

All these solutions are the same as $x = 0^\circ + k90^\circ$ for $k \in \mathbb{Z}$.

[4]

What you should be able to do:

- Simplify expression, without a calculator by using a sketch.
- Use reduction formulae and/or co-functions
- Use special angles
- Derive and use the trig identities: (Quotient, square, compound and double angle identities).
- Determine for which values an identity is undefined
- Determine the general solution of trigonometric equations
- Solve trigonometric equations with a given interval
- Use identities to prove identities and solve equations



Feb/March 2014 Q8 & Q9.1 & 9.2

Nov 2013 Q10 & Q11

Feb/March 2013 Q8 & Q9

Nov 2012 Q8 & Q9

Feb/March 2012 Q11 & Q12

Nov 2011 Q9.1 & 9.2 & Q12

Feb/March 2011 Q10



Keep going!

11

Unit

Trigonometry: Sine, cosine and area rules

We use these three rules to find the lengths of sides, sizes of angles and the area of any kind of triangle. To 'solve a triangle' means you must calculate the unknown sides and angles.

11.1 Right-angled triangles

You can use the trig ratios to find angles and lengths of a right-angled triangle.



Activity 1

In triangle ABC , $\hat{B} = 37^\circ$ and $AC = 16$ cm. $\hat{C} = 90^\circ$. Calculate the length of AB and BC (correct to one decimal place). (3)

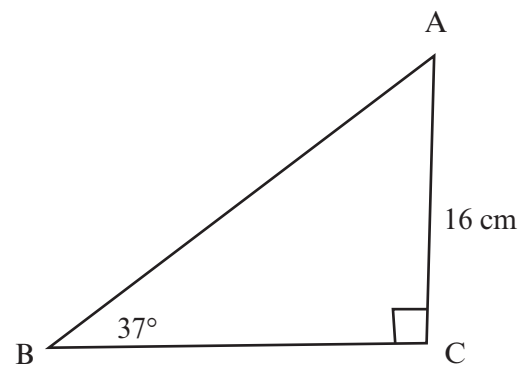

[3]

Solution

To calculate the length of AB , use 37° as the reference angle, then $AC = 16$ cm is the opposite side and AB is the hypotenuse. Use the sine ratio.

$$\sin 37^\circ = \frac{\text{opp}}{\text{hyp}} = \frac{16}{AB}$$

$$AB \sin 37^\circ = 16$$

$$AB = \frac{16}{\sin 37^\circ} = 26,6 \text{ cm } \checkmark$$

To find the length of BC , you can use

$$\cos 37^\circ = \frac{\text{adj}}{\text{hyp}} = BC/26,6$$

$$26,6 \cos 37^\circ = BC \checkmark$$

$$BC = 21,2 \text{ cm (to one decimal place) } \checkmark$$

You can also use Pythagoras' theorem:

$$AB^2 = AC^2 + BC^2$$

[3]



Activity 2

In triangle PQR, $PQ = 12,3$ m and $PR = 13$ m. Calculate the size of \hat{Q} . (2)

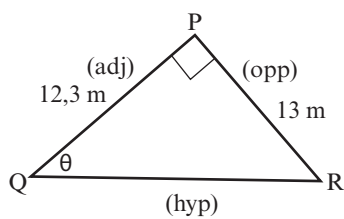

[2]

Solution

Use PQ and PR.

$$\tan \theta = \frac{\text{opp}}{\text{adj}} = \frac{13}{12,3} \checkmark$$

$$\theta = \tan^{-1} \left(\frac{13}{12,3} \right) = 46,58^\circ \checkmark$$

[2]

11.2 Area rule

Area of a right-angled triangle:

$$\text{Area } \Delta = \frac{1}{2} \text{ base} \times \text{perpendicular height}$$

$$\text{Area } \Delta = \frac{1}{2} bh$$

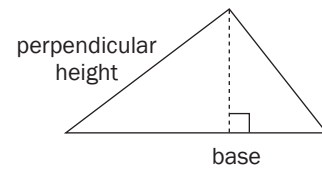
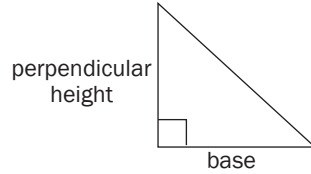

Proof of Area rule [STUDY FOR EXAM PURPOSE]

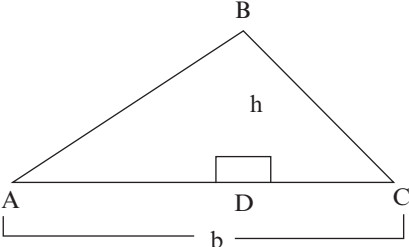
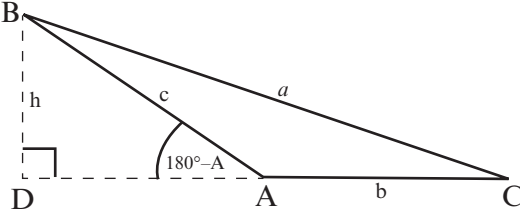
<p>If \hat{A} is acute</p>  <p>Area of $\Delta ABC = \frac{1}{2} bh \dots \dots \dots (1)$ But $\sin A = \frac{h}{c} \therefore h = c \sin A$ Substituting into (1) Area of $\Delta ABC = \frac{1}{2} bc \sin A$ Similarly it can be shown that Area of $\Delta ABC = \frac{1}{2} ab \sin C$ $= \frac{1}{2} ac \sin B$</p>	<p>If \hat{A} is obtuse</p>  <p>Area of $\Delta ABC = \frac{1}{2} bh \dots \dots \dots (1)$ But $\sin (180^\circ - A) = \frac{h}{c} \therefore h = c \sin A$ Substituting into (1) Area of $\Delta ABC = \frac{1}{2} bc \sin A$ Similarly it can be shown that Area of $\Delta ABC = \frac{1}{2} ab \sin C$ $= \frac{1}{2} ac \sin B$</p>
---	--



If a base or height is unknown, you can use trig ratios to work them out. If the perpendicular height is not given and cannot be worked out, then we need a different area formula.

There is a formula that works to find the area of *any* triangle, even if we do not know the perpendicular height.

The area of any $\triangle ABC$ is half the product of two sides and sine of the included angle.

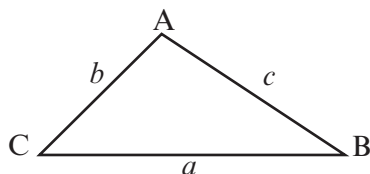

So if you choose to use angle A, then

$$\text{Area } \triangle ABC = \frac{1}{2} bc \sin A$$

If you choose to use angle B, then

$$\text{Area } \triangle ABC = \frac{1}{2} ac \sin B$$

If you choose to use angle C, then

$$\text{Area } \triangle ABC = \frac{1}{2} ab \sin C$$

Learn one form of the formula – you can work out the others from that.

To find the area of any triangle, you need to know the lengths of two sides and the size of the angle between the two sides.



Calculate the area of $\triangle MNK$ with $m = 3,5$ cm;

$n = 4,8$ cm and $\hat{K} = 112^\circ$.

Choose the version of the formula that uses the sides m and n and the angle K because these are known values.

$$\begin{aligned} \text{Area } \triangle MNK &= \frac{1}{2} mn \sin K \\ &= \frac{1}{2} (3,5)(4,8) \sin 112^\circ \\ &= 8,4 \sin 112^\circ \\ &= 7,788 \text{ cm}^2 \text{ (correct to 3 decimal places)} \end{aligned}$$

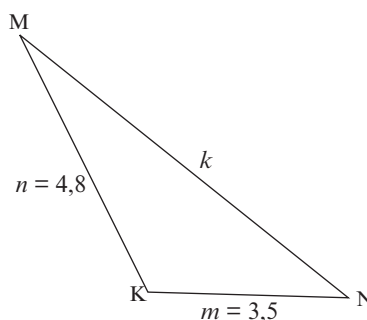

11.3 Sine rule

If you have enough information about the sides and angles of any triangle, you can use the sine rule to find the other sides and angles.

Sine rule

The ratio of sine of the angle divided by the side opposite that angle is the same for all three pairs of sides and angles.

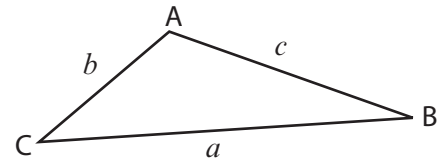

So ...

In any triangle ABC:

$$\frac{\sin A}{a} = \frac{\sin B}{b} = \frac{\sin C}{c}$$

We can also use the ratios with the sides in the numerator:

$$\frac{a}{\sin A} = \frac{b}{\sin B} = \frac{c}{\sin C}$$

The formula will be provided on the information sheet

Proof of Sine rule [STUDY FOR EXAM PURPOSE]

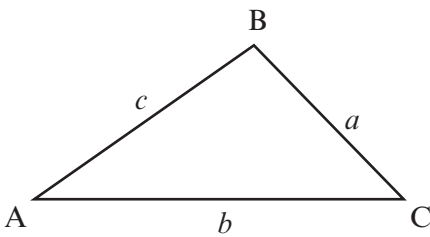
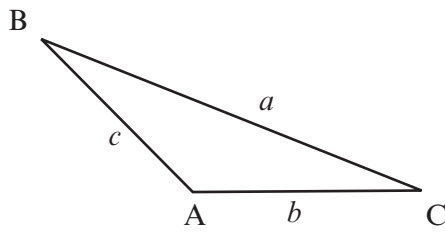
<p>If \hat{A} is acute</p> 	<p>If \hat{A} is obtuse</p> 
<p>Using Area rule for ΔABC:</p> $\frac{1}{2} bc \sin A = \frac{1}{2} ab \sin C = \frac{1}{2} ac \sin B$ <p>Dividing each by $\frac{1}{2} abc$ results: $\frac{\sin A}{a} = \frac{\sin C}{c} = \frac{\sin B}{b}$</p>	



To use the **sine rule** you need to know at least one side and its matching opposite angle and one more side or angle.

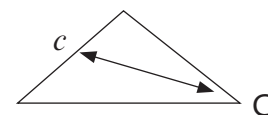
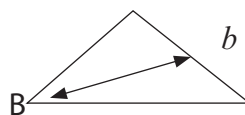
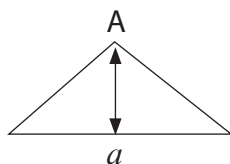

The sine rule can be used to solve many problems if the right information about the triangle is given.



Activity 3

Solve $\triangle XYZ$ in which $z = 7,3 \text{ m}$, $\hat{X} = 43^\circ$ and $\hat{Y} = 96^\circ$. Give your solutions correct to 3 decimal places. (4)

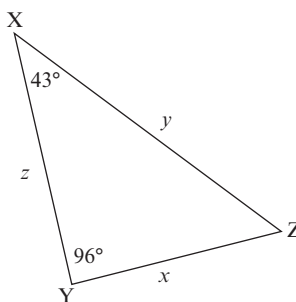

[4]

Solution

The angle opposite the known side is not given, but you can work it out.

$\hat{Z} = 180^\circ - (43^\circ + 96^\circ)$ (sum angles of Δ) Using the sine rule again to find x :

$$\hat{Z} = 41^\circ \quad \checkmark$$

To find y : $\frac{y}{\sin 96^\circ} = \frac{7,3}{\sin 41^\circ} \quad \checkmark$

$$y = \frac{7,3 \sin 96^\circ}{\sin 41^\circ}$$

$$y = 11,066 \text{ m} \quad \checkmark$$

$$\frac{x}{\sin 43^\circ} = \frac{7,3}{\sin 41^\circ}$$

$$x = \frac{7,3 \sin 43^\circ}{\sin 41^\circ}$$

$$x = 7,589 \text{ m} \quad \checkmark$$

[4]

11.4 Cosine rule

You apply the **cosine rule** If you are given the values of:

- two sides and the included angle OR
- three sides of a triangle,

Cosine rule:

In any triangle ABC:

If you choose to use angle A, then

$$a^2 = b^2 + c^2 - 2bc \cos A$$

If you choose to use angle B, then

$$b^2 = a^2 + c^2 - 2ac \cos B$$

If you choose to use angle C, then

$$c^2 = a^2 + b^2 - 2ab \cos C$$

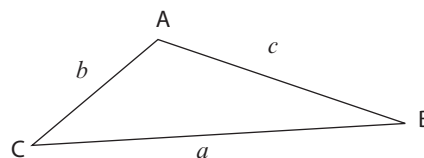

Proof of Cosine rule [STUDY FOR EXAM PURPOSE]

<p>If \hat{A} is acute</p> <p>In $\triangle BDC$: $a^2 = BD^2 + CD^2$ (Pythagoras Theorem) $= BD^2 + (b - AD)^2$ $= BD^2 + b^2 - 2bAD + AD^2$ But $BD^2 + AD^2 = c^2$ (Pythagoras Theorem) Thus $a^2 = b^2 + c^2 - 2bAD$(1) In $\triangle ABD$: $\cos A = \frac{AD}{c} \therefore AD = c \cos A$(2) Substituting (2) into (1) $\therefore a^2 = b^2 + c^2 - 2bc \cos A$ Similarly it can be shown that: $b^2 = a^2 + c^2 - 2ac \cos B$ and $c^2 = a^2 + b^2 - 2ab \cos C$</p>	<p>If \hat{A} is obtuse</p> <p>In $\triangle BDC$: $a^2 = BD^2 + CD^2$ (Pythagoras Theorem) $= BD^2 + (b + AD)^2$ $= BD^2 + b^2 + 2bAD + AD^2$ But $BD^2 + AD^2 = c^2$ (Pythagoras Theorem) Thus $a^2 = b^2 + c^2 + 2bAD$(1) In $\triangle ABD$: $\cos(180^\circ - A) = \frac{AD}{c} \therefore AD = -c \cos A$.....(2) Substituting (2) into (1) $\therefore a^2 = b^2 + c^2 - 2bc \cos A$ Similarly it can be shown that: $b^2 = a^2 + c^2 - 2ac \cos B$ and $c^2 = a^2 + b^2 - 2ab \cos C$</p>
--	---

e.g. 2

1. Solve ΔPQR if $q = 462$ mm, $p = 378$ mm and $\hat{R} = 87^\circ$.

Using the cosine rule

(two sides and the included angle are given so you can find the side opposite the given angle)

$$PQ^2 = p^2 + q^2 - 2pq \cos R$$

$$PQ^2 = (378)^2 + (462)^2 - 2(378)(462) \cos 87^\circ$$

$$PQ^2 = 338\,048,5159$$

$$PQ = 581,42 \text{ mm} \quad [\text{take square root}]$$

Using the sine rule:

$$\frac{378}{\sin P} = \frac{581,42}{\sin 87^\circ}$$

$$\frac{\sin P}{378} = \frac{\sin 87^\circ}{581,42} \quad (\text{it is easier to have } \hat{P} \text{ in the numerator})$$

$$\sin P = \frac{378 \times \sin 87^\circ}{581,42}$$

$$\sin P = 0,649$$

$$\hat{P} = \sin^{-1}(0,649) = 40,48^\circ$$

$$\therefore \hat{Q} = 180^\circ - (87^\circ + 40,48^\circ) = 52,52^\circ \quad [\text{sum angles of } \Delta]$$

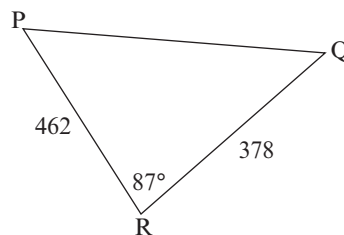

2. Determine the biggest angle in ΔABC if $a = 7$ cm; $b = 9$ cm and $c = 15$ cm.

You are given three sides, so use the cosine rule.

The biggest angle will be \hat{C} (opposite the longest side).

$$\left. \begin{aligned} c^2 &= a^2 + b^2 - 2ab \cos C \\ 2ab \cos C &= a^2 + b^2 - c^2 \\ \cos C &= \frac{a^2 + b^2 - c^2}{2ab} \end{aligned} \right\} \begin{array}{l} \text{rearrange the formula to get } \cos C \\ \text{on its own} \end{array}$$

$$\cos C = \frac{7^2 + 9^2 - 15^2}{2(7)(9)}$$

$$\cos C = -0,753968\dots \quad \cos \theta \text{ is negative in quad 2, so } \hat{C} \text{ is obtuse.}$$

reference angle is $41,06^\circ$

$$\hat{C} = 180^\circ - 41,06\dots^\circ = 138,94^\circ \quad (\text{correct to two decimal places})$$

11.5 Problems in two and three dimensions



Activity 4

1. PQRS is a trapezium with $PQ \parallel SR$, $PQ = PS$, $SR = 10$ cm, $QR = 7$ cm, $\hat{R} = 63^\circ$.

Calculate:

- SQ
- PS
- area of quadrilateral PQRS. (correct to 2 decimal places)

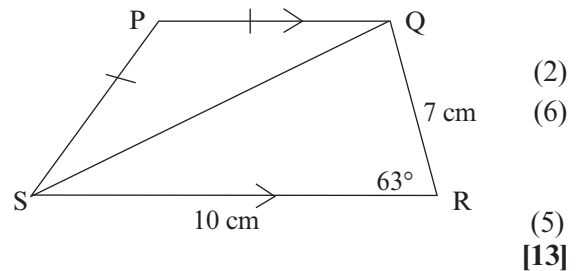

(2)
(6)
(5)
[13]



NB
When solving triangles, start with the triangle which has most information (i.e. triangle with three sides or two sides and an angle or two angles and a side given)

Solutions

- a) In $\triangle QSR$, you know two sides and the included angle, so use the cosine rule.

$$SQ^2 = 7^2 + 10^2 - 2(7)(10)\cos 63^\circ \quad \checkmark$$

$$SQ^2 = 85,44\dots \quad \text{find the square root}$$

$$SQ = 9,24 \text{ cm} \quad \checkmark \quad (2)$$

- b) In $\triangle PQS$, you know that $PQ = PS$ and you worked out that $SQ = 9,24$ cm.

Think about the question first

If you can find \hat{P} then you can use the sine rule to find PS.

To find \hat{P} , you need to first find \hat{PQS} or \hat{PSQ} .

$$\hat{PQS} = \hat{PSQ} \text{ (alternate angles, } PQ \parallel SR)$$

Now can you work out a value for \hat{QSR} ?

In $\triangle QSR$, you know three sides and \hat{R} .

So it is easiest to use the sine rule to find \hat{QSR} .

$$\frac{\sin \hat{QSR}}{7} = \frac{\sin 63^\circ}{9,24} \quad \checkmark$$

$$\sin \hat{QSR} = \frac{7 \sin 63^\circ}{9,24} = 0,675004$$

$$\therefore \hat{QSR} = 42,45^\circ \quad \checkmark$$

$$\hat{PQS} = \hat{QSR} = 42,45^\circ \quad \text{(alternate angles, } PQ \parallel SR)$$

$$\hat{PQS} = \hat{PSQ} = 42,45^\circ \quad \text{(base angles of isosceles } \triangle)$$

$$\therefore \hat{P} = (180^\circ - (42,45^\circ + 42,45^\circ)) \quad \checkmark$$

$$= 95,1^\circ \quad \checkmark \quad \text{(sum angles in } \triangle)$$

Now we can find PS using the sine rule and \hat{P} .

$$\text{In } \triangle PQS \quad \frac{PS}{\sin 42,45^\circ} = \frac{9,24}{\sin 95,1^\circ} \quad \checkmark$$

$$PS = \frac{9,24 \sin 42,45^\circ}{\sin 95,1^\circ}$$

$$PS = 6,26 \text{ cm} \quad \checkmark \quad (6)$$

- c) To find the areas of PQRS, find the area of the two triangles and add them together.

To find the area of ΔPQS , use $\hat{P} = 95,1^\circ$ and $PS = PQ = 6,26$ cm.

$$\text{Area } \Delta PQS = \frac{1}{2}qs \sin P \quad \checkmark$$

$$\text{Area } \Delta PQS = \frac{1}{2} (6,26)(6,26)\sin 95,1^\circ$$

$$\text{Area } \Delta PQS = 19,52 \text{ m}^2 \quad \checkmark$$

To find the area of ΔRQS , use $\hat{R} = 63^\circ$, $QR = 7$ cm and $SR = 10$ cm.

$$\text{Area } \Delta RQS = \frac{1}{2} (7)(10)\sin 63 \quad \checkmark$$

$$\text{Area } \Delta RQS = 31,19 \text{ m}^2 \quad \checkmark$$

$$\therefore \text{Area PQRS} = 19,52 + 31,19 = 50,71 \text{ m}^2 \quad \checkmark$$

(5)

[13]

Activity 5

In the diagram alongside, $AC = 7$ cm,
 $DC = 3$ cm, $AB = AD$, $\hat{DCA} = 60^\circ$,
 $\hat{DAB} = \beta$ and $\hat{ABD} = \theta$.

Show that $BD = \frac{\sqrt{37} \sin \beta}{\sin \theta}$

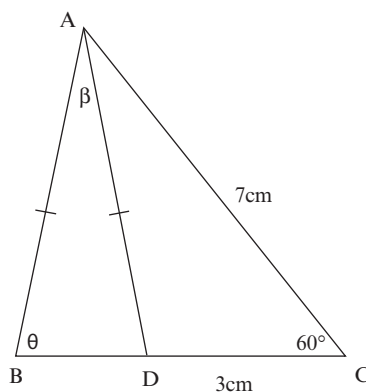
**[3]**

Solution

$$AD^2 = AC^2 + CD^2 - 2AC \cdot CD \cos 60^\circ = (7)^2 + (3)^2 - 2 \times 7 \times 3 \times 0,5 \quad \checkmark$$

$$AD^2 = 58 - 21$$

$$AD^2 = 37$$

$$AD = \sqrt{37}$$

Applying sine rule:

$$\frac{BD}{\sin \beta} = \frac{AD}{\sin \theta} \Rightarrow BD = \frac{AD \sin \beta}{\sin \theta} \quad \text{but } AD = \sqrt{37} \quad \checkmark$$

$$\therefore BD = \frac{\sqrt{37} \sin \beta}{\sin \theta} \quad \checkmark$$

[3]



Activity 6

1. In the diagram alongside, ABC is a right angled triangle.

KC is the bisector of \hat{ACB} . $AC = r$ units and $\hat{BCK} = x$

1.1 Write down AB in terms of x

(2)

1.2 Give the size of \hat{AKC} in terms of x

(2)

1.3 If it is given that $\frac{AK}{AB} = \frac{2}{3}$, calculate the value of x

(7)

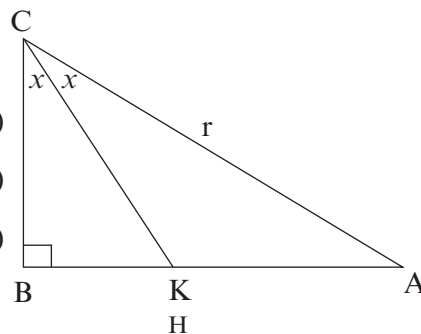

2. A, B and L are points in the same horizontal plane, HL is a vertical pole of length 3 metres, $AL = 5,2$ m, the angle $\hat{ALB} = 113^\circ$ and the angle of elevation of H from B is 40° .

2.1 Calculate the length of LB.

(3)

2.2 Hence, or otherwise, calculate the length of AB.

(3)

2.3 Determine the area of $\triangle ABL$.

(3)

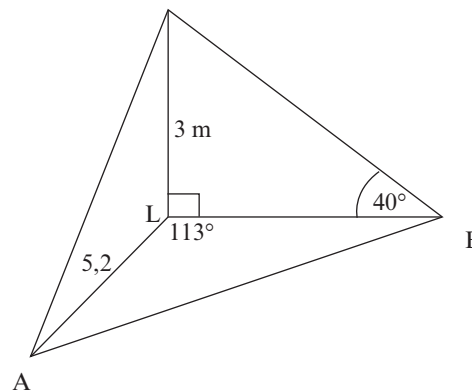

3. The angle of elevation from a point C on the ground, at the centre of the goalpost, to the highest point A of the arc, directly above the centre of the Moses Mabhida soccer stadium, is $64,75^\circ$. The soccer pitch is 100 metres long and 64 metres wide as prescribed by FIFA for world cup stadiums. Also $AC \perp PC$.

In the figure below $PQ = 100$ metres and $PC = 32$ metres

3.1 Determine \hat{AC}

(2)

3.2 Calculate \hat{PAC}

(2)

3.3 A camera is placed at D, 40 m directly below point A, calculate the distance from D to C

(4)

[28]

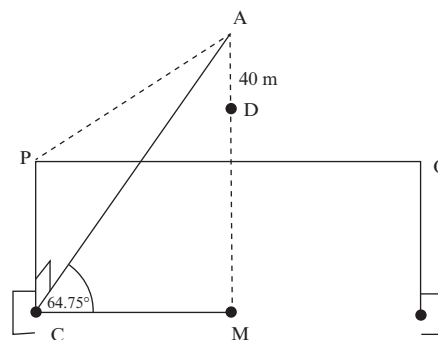

Solutions

$$1.1 \sin 2x = \frac{AB}{r} \therefore AB = r \sin 2x \quad \checkmark \checkmark \quad (2)$$

$$1.2 \hat{AKC} = 90^\circ + x \quad [\text{ext. angle of } \triangle CBK] \quad \checkmark \checkmark \quad (2)$$

$$1.3 \frac{AK}{\sin x} = \frac{r}{\sin(90^\circ + x)} \therefore AK = \frac{r \sin x}{\cos x} \quad \checkmark \checkmark$$

$$\frac{AK}{AB} = \frac{\frac{r \sin x}{\cos x}}{r \sin 2x} = \frac{r \sin x}{r \cos x \cdot 2 \cos x \sin x} = \frac{1}{2 \cos^2 x} = \frac{2}{3} \quad \checkmark \checkmark$$

$$\therefore \cos^2 x = \frac{3}{4} \quad \checkmark$$

$$\cos x = \frac{\sqrt{3}}{2} \quad \checkmark$$

$$\text{Hence } x = 30^\circ \quad \checkmark \quad (7)$$

$$2.1 \text{ In } \triangle HLB, \tan 40^\circ = \frac{3}{LB} \quad \checkmark$$

[\triangle HLB is right-angled, so use a trig ratio]

$$LB = \frac{3}{\tan 40^\circ} \quad \checkmark$$

$$LB = 3,5752\dots \approx 3,58 \text{ metres} \quad \checkmark \quad (3)$$

2.2 In $\triangle ABL$,

[\triangle ABL not right-angled. You have two sides and included angle, so use the Cosine Rule]

$$AB^2 = AL^2 + BL^2 - 2(AL)(BL) \cdot \cos L \quad \checkmark$$

$$AB^2 = (5,2)^2 + (3,58)^2 - 2(5,2)(3,58) \cdot \cos 113^\circ \quad \checkmark$$

$$AB^2 = 54,40410\dots \text{ m}^2$$

$$AB = 7,38 \text{ m} \quad \checkmark \quad (3)$$

$$2.3 \text{ Area } \triangle ABL = \frac{1}{2} AL \times BL \times \sin \hat{ALB} \quad \checkmark$$

$$= \frac{1}{2} (5,2) \times (3,58) \times \sin 113^\circ \quad \checkmark$$

$$= 8,56805\dots \quad \checkmark$$

$$\approx 8,57 \text{ m}^2 \quad \checkmark \quad (3)$$

$$3.1 \cos 64,75^\circ = \frac{CM}{AC} \therefore AC = \frac{CM}{\cos 64,75^\circ} = \frac{50\text{m}}{0,426569} = 117,21 \quad \checkmark \checkmark \quad (2)$$

$$3.2 \tan \hat{PAC} = \frac{PC}{AC}$$

$$\hat{PAC} = \tan^{-1} \left(\frac{32}{AC} \right) \quad \checkmark$$

$$= 15,27^\circ \quad \checkmark \quad (2)$$

$$3.3 DC^2 = AC^2 + AD^2 - 2AC \cdot AD \cos(90^\circ - 64,75^\circ) \quad \checkmark$$

$$DC^2 = (117,21)^2 + (40)^2 - 2(117,21) \cdot 40 \cos(25,25^\circ) \quad \checkmark$$

$$= 6857,289 \quad \checkmark$$

$$DC = 82,81 \text{ m} \quad \checkmark \quad (4)$$

[28]

What you should be able to do:

- Derive and use the trig identities: $\tan \theta = \frac{\sin \theta}{\cos \theta}$ and $\sin^2 \theta + \cos^2 \theta = 1$.
- Derive and use reduction formulae to simplify expressions.
- Determine for which values of a variable an identity is true.
- Derive and use the sine, cosine and area rules.
- Apply the sine, cosine and area rules to solve triangles in 2-D and 3-D problems.
- Use the compound angle and double angle identities where necessary to prove and make necessary calculations.



November 2013	Question 13
February/March 2013	Question 11
February/March 2012	Question 12
November 2012	Question 12
November 2011	Question 11
November 2010	Question 11



Euclidean Geometry

12.1 Revise: Proportion and area of triangles

1. Ratio and proportion

Ratio compares two measurements of the same kind using the same units.

Example

If Line A is 2 units long and Line B is 6 units long, then the ratio of Line A : Line B is 2 : 6.

This is the same ratio as 1 : 3. Line C is 1 unit long and Line D is 3 units long.

So Line C : Line D is 1 : 3. So C and D are in the same proportion as A and B.

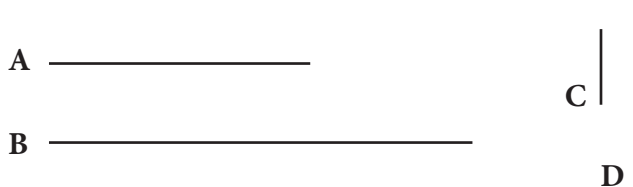

So the two ratios are equal and we can say that $\frac{A}{B} = \frac{C}{D}$

We say that A, B, C and D are **in proportion**.

This proportion can be written in many ways:

If $\frac{A}{B} = \frac{C}{D}$, then 1. $\frac{A}{C} = \frac{B}{D}$ 2. $\frac{B}{A} = \frac{D}{C}$ 3. $\frac{C}{A} = \frac{D}{B}$

Ratio and proportion of areas and sides of triangles

1. If two or more triangles have a common vertex (A) and lie between the same parallel lines, they also have a common perpendicular height (altitude).

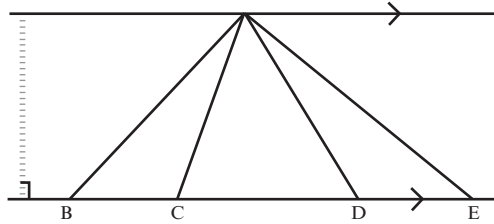

2. The areas of triangles with equal altitudes are in the same proportion as their bases.

Remember: $\text{area } \Delta = \frac{1}{2} \text{ base} \times \text{perp height}$

ΔADB , ΔDBC and ΔADC all have the same \perp height DE .

So Area ΔADB : Area ΔDBC : Area ΔADC

$$\left(\frac{1}{2} AB \times DE\right) : \left(\frac{1}{2} BC \times DE\right) : \left(\frac{1}{2} AC \times DE\right) \quad AB : BC : AC$$

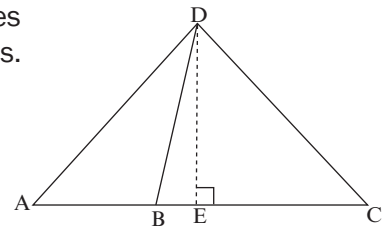

3. If two or more triangles lie between parallel lines, they have the same altitude.

4. Triangles on the same base (or equal bases) and between parallel lines are equal in area.

$$\text{Area } \Delta ABC = \frac{1}{2}(AB)h$$

$$\text{Area } \Delta ADB = \frac{1}{2}(AB)h$$

$$\text{Area } \Delta ABC = \text{Area } \Delta ADB$$

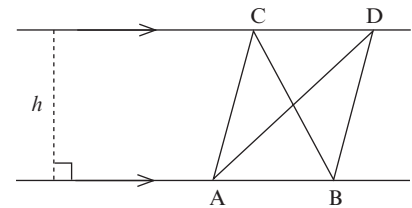

12.2 Proportion theorems

Theorem 7 (Learn the proof for the examination)

Proportional Theorem

If a line is drawn parallel to one side of a triangle, it divides the other two sides in the same proportion.

(Prop theorem, $DE \parallel BC$)

Given: Triangle ABC with D on AB and E on AC, $DE \parallel BC$

To prove: $\frac{AD}{DB} = \frac{AE}{EC}$

Proof: Construction: Draw altitudes h and k in $\triangle ADE$

Join DC and BE

$$\frac{\text{Area of } \triangle ADE}{\text{Area of } \triangle BDE} = \frac{\frac{1}{2} \cdot AD \cdot h}{\frac{1}{2} \cdot DB \cdot h} = \frac{AD}{DB} \text{ (same altitude } h)$$

and $\frac{\text{Area of } \triangle ADE}{\text{Area of } \triangle CED} = \frac{\frac{1}{2} \cdot AE \cdot k}{\frac{1}{2} \cdot EC \cdot k} = \frac{AE}{EC}$ (same altitude k)

but Area $\triangle ADE$ = Area $\triangle CED$ (same base DE; same altitude; $DE \parallel BC$)

$$\therefore \frac{\text{Area of } \triangle ADE}{\text{Area of } \triangle BDE} = \frac{\text{Area of } \triangle ADE}{\text{Area of } \triangle CED}$$

$$\therefore \frac{AD}{DB} = \frac{AE}{EC}$$

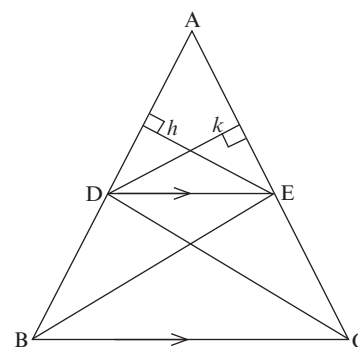

Solving problems using proportion



Activity 1

1. Determine the value of x , in the diagram alongside, if $PQ \parallel BC$. (4)

Solution

$$\frac{AP}{PB} = \frac{AQ}{QC} \checkmark \text{ (PQ } \parallel \text{ BC, prop theorem) } \checkmark$$

$$\therefore \frac{5}{3} = \frac{4}{x} \checkmark$$

$$\therefore 5x = (3)(4)$$

$$\therefore x = \frac{12}{5} = 2,4 \text{ cm } \checkmark$$

[4]

2. In $\triangle ABC$, $AB \parallel FD$; $AF \parallel DE$
and $FE : EC = 3 : 4$.
Determine $EC : BF$

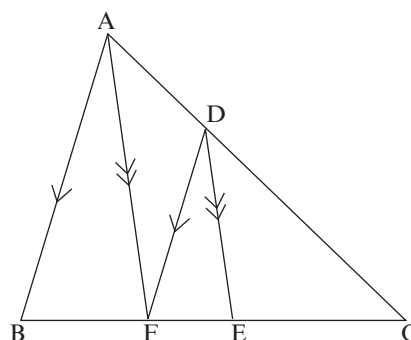

NOTE:

3 : 4 does not mean that
 $FE = 3$ and $EC = 4$.

For any a , we can say that
 $FE = 3a$ and $EC = 4a$

For every 3 of a in FE , there is
4 of a in EC .

(7)

Solution

Work with two different triangles:
 $\triangle ACF$ and $\triangle ABC$

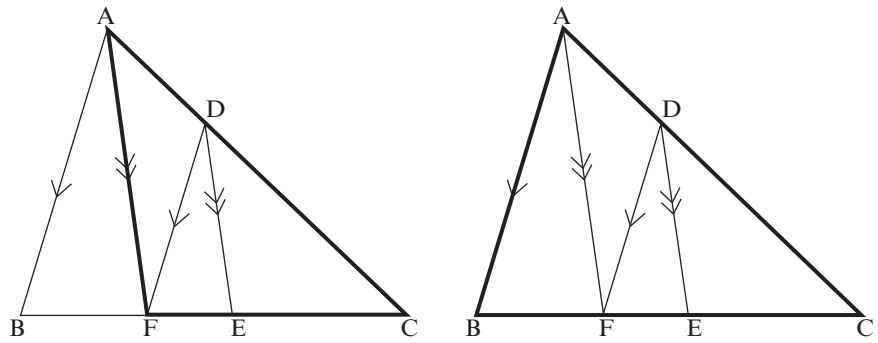

In $\triangle ACF$:

$$\frac{AD}{DC} = \frac{FE}{EC} \quad \checkmark \quad (AF \parallel DE, \text{prop intercept theorem}) \quad \checkmark$$

In $\triangle ABC$:

$$\frac{AD}{DC} = \frac{BF}{FC} \quad (AB \parallel FD, \text{prop intercept theorem}) \quad \checkmark$$

$$\therefore \frac{FE}{EC} = \frac{BF}{FC} \quad (\text{both} = \frac{AD}{DC}) \quad \checkmark$$

$$\frac{FE}{EC} = \frac{3a}{4a} \quad \text{and} \quad \frac{BF}{FC} = \frac{BF}{7a}$$

$$\therefore \frac{3a}{4a} = \frac{BF}{7a} \quad \checkmark$$

$$\therefore BF = 3\left(\frac{7a}{4}\right) = \frac{21a}{4} \quad \checkmark$$

$$\therefore \frac{EC}{BF} = 4a \div \frac{21a}{4}$$

$$= \frac{4a}{1} \times \frac{4}{21a}$$

$$= \frac{16}{21} \quad \checkmark$$

$$\therefore EC : BF = 16 : 21$$

[7]

3. Determine the value of x if $PQ \parallel BC$. (4)

Solution

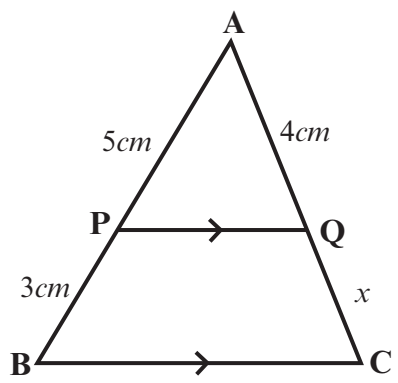

$$\frac{AP}{PB} = \frac{AQ}{QC} \checkmark \quad (\text{prop theorem, } PQ \parallel BC) \checkmark$$

$$\frac{5}{3} = \frac{4}{x} \checkmark$$

$$5x = (3)(4)$$

$$x = \frac{12}{5} = 2,4\text{cm} \checkmark$$

[4]

4. In the diagram, $RF \parallel KG$, $ED \parallel KH$,
 $RH = 3$ units, $RK = 9$ units, $HF = 2$ units. $GE:EK = 1:3$

Calculate (stating reasons) the lengths of:

- 4.1 FG
 4.2 FD

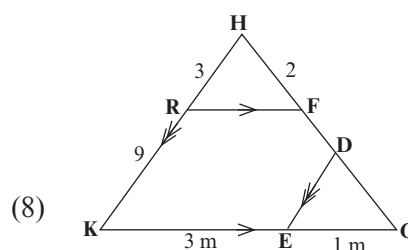

Solutions

4.1
 In ΔHKG
 $\frac{FG}{2} = \frac{9}{3} \checkmark S$ (line \parallel one side of a Δ) $\checkmark R$ or ($RF \parallel KG$)
 $FG = 6$ units $\checkmark S$ (3)

4.2 $\frac{GD}{GH} = \frac{GE}{GK} = \frac{1}{4} \checkmark S$ (line \parallel one side of a Δ) $\checkmark R$ or ($ED \parallel KH$)
 $GD = \frac{1}{4} \cdot GH$
 $GD = \frac{1}{4} \cdot (8) \checkmark S$
 $GD = 2 \checkmark S$
 $\therefore FD = 6 - 2 = 4$ units $\checkmark R$

OR
 In ΔHKG , $HK \parallel DE$
 $\frac{GD}{DH} = \frac{EG}{EK} = \frac{1}{3} \checkmark S$
 (line \parallel one side of a Δ) $\checkmark R$
 or (proportional theorem, $HK \parallel DE$)
 $\frac{6 - FD}{2 + FD} = \frac{1}{3} \checkmark S$
 $18 - 3FD = 2 + FD \checkmark$
 $\therefore FD = 4$ units \checkmark (5)

[8]

12.3 Similar polygons

Similar polygons have the same shape, but not necessarily the same size.



Every **square** is similar to every other **square**.

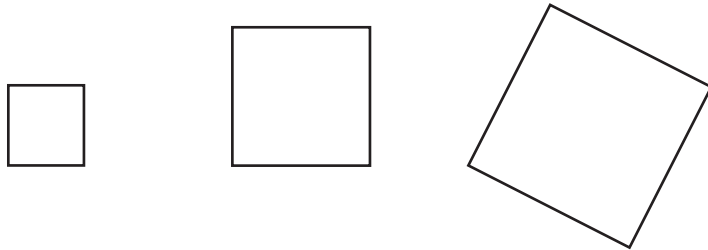

Polygons (with the same number of sides) are **similar** when:

- All the pairs of **corresponding angles** are equal (They are **equiangular**)
and
- All the pairs of **corresponding sides** are in the same proportion.
Both of these conditions must hold at the same time.

||| is the symbol we use to say one polygon '**is similar to**' another polygon.

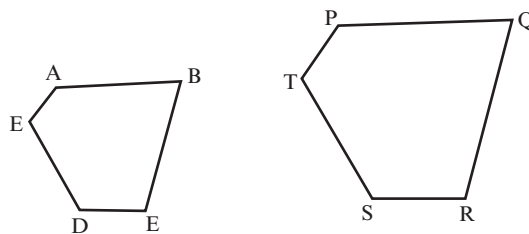

Corresponding sides are sides in the same position (with respect to the angles) in each polygon.

Consider pentagon ABCDE and pentagon PQRST

$$\hat{A} = \hat{P}; \hat{B} = \hat{Q}; \hat{C} = \hat{R}; \hat{D} = \hat{S}; \hat{E} = \hat{T}$$

AND

$$\frac{AB}{PQ} = \frac{BC}{QR} = \frac{DC}{SR} = \frac{ED}{TS} = \frac{EA}{TP}$$

\therefore ABCDE ||| PQRST (equiangular and corresponding sides in the same proportion)

Triangles are special polygons:

- If two triangles are equiangular, then their sides will always be in the same proportion, so the triangles are **similar**.
- If the sides of two triangles are in the same proportion, then the triangles will be equiangular, so the triangles are **similar**.

equiangular Δ s \rightarrow similar Δ s
corresponding sides Δ s in proportion \rightarrow Δ s are similar

Theorem 9 (Learn the proof for the examination)

If two triangles are equiangular, then the corresponding sides are in proportion and therefore the triangles are similar.

Given: $\triangle ABC$ and $\triangle DEF$ with $\hat{A} = \hat{D}$; $\hat{B} = \hat{E}$; $\hat{C} = \hat{F}$

To prove: $\frac{DE}{AB} = \frac{EF}{BC} = \frac{DF}{AC}$

Proof: On AB mark off AP = DE and on AC mark off AQ = DF

Draw PQ

In $\triangle APQ$ and $\triangle DEF$

AP = DE (Construction)

$\hat{A} = \hat{D}$ (given)

AQ = DF (Construction)

$\therefore \triangle APQ \equiv \triangle DEF$ (SAS)

$\therefore \hat{P}_1 = \hat{E}$

$\therefore \hat{P}_1 = \hat{B}$ ($\hat{E} = \hat{B}$)

$\therefore PQ \parallel BC$ (Corresponding \angle s equal)

$\therefore \frac{AP}{AB} = \frac{AQ}{AC}$ (PQ \parallel BC in $\triangle ABC$)

But AP = DE and AQ = DF

$\therefore \frac{DE}{AB} = \frac{DF}{AC}$

Similarly, we can prove that

$\frac{DE}{AB} = \frac{EF}{BC}$

$\therefore \frac{DE}{AB} = \frac{EF}{BC} = \frac{DF}{AC}$

But the triangles are equiangular

$\therefore \triangle ABC \sim \triangle DEF$

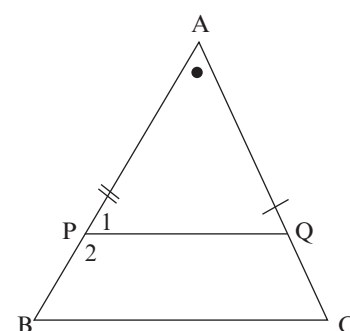
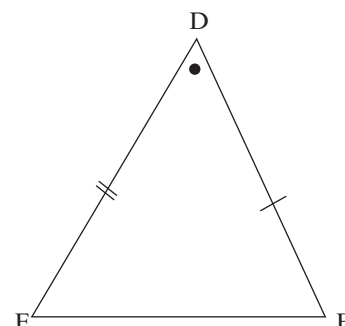
**NOTE:**

If two triangles have 2 corresponding angles equal, then **the third angles will equal each other** (sum angles of a triangle = 180°) and the triangles are therefore similar and their sides will be in proportion. The shortened reason you can use is (*third angle*)

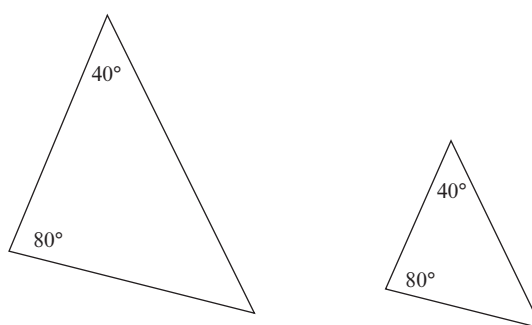

If two angles are the same, then the 3rd angle of both triangles is $180^\circ - (40^\circ + 80^\circ)$ (sum angles in \triangle) = 60°

Theorem 10 (Learn the proof for the examination)

If two triangles have their sides in the same proportion, then the corresponding angles will be equal and the triangles are similar.

Given: $\triangle ABC$ and $\triangle DEF$ with $\frac{DE}{AB} = \frac{EF}{BC} = \frac{DF}{AC}$

To prove: $\hat{A} = \hat{D}$; $\hat{B} = \hat{E}$; $\hat{C} = \hat{F}$

Proof: Draw $\triangle PEF$ so that $\hat{PEF} = \hat{B}$ and $\hat{EFP} = \hat{C}$

$\therefore \triangle PEF \parallel \triangle ABC$ (equiangular \triangle s)

$$\therefore \frac{PE}{AB} = \frac{EF}{BC} = \frac{PF}{AC}$$

But $\frac{DE}{AB} = \frac{EF}{BC} = \frac{DF}{AC}$ (Given)

$\therefore PE = ED$ and $PF = DF$

and EF is common

$\therefore \triangle DEF \equiv \triangle PEF$ (SSS)

$$\therefore \hat{F}_1 = \hat{F}_2 = \hat{C}$$

and $\hat{E}_1 = \hat{E}_2 = \hat{B}$

i.e. $\hat{A} = \hat{D}$; $\hat{B} = \hat{E}$; $\hat{C} = \hat{F}$

But the corresponding sides of the triangles are proportional

$\therefore \triangle ABC \parallel \triangle DEF$

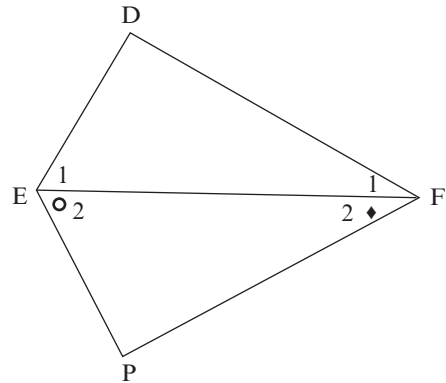
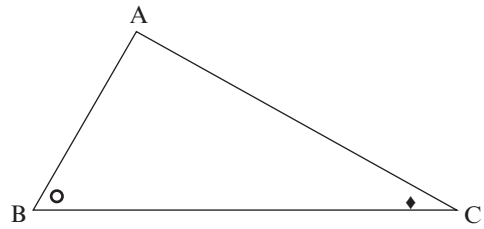

Theorem 11 (Learn the proof for the examination)

Theorem of Pythagoras (proved using similar triangles)

In any right-angled triangle, the square on the hypotenuse is equal to the sum of the squares on the other two sides.

Given: $\triangle ABC$ with $\hat{A} = 90^\circ$

To Prove: $BC^2 = AB^2 + AC^2$

Proof: Draw $AD \perp BC$

In $\triangle ABD$ and $\triangle CBA$

\hat{B} is common

$\hat{ADB} = \hat{CAB} = 90^\circ$ (given)

$\hat{BAD} = \hat{BCA}$ (3rd \angle of \triangle)

$\therefore \triangle ABD \parallel \triangle CBA$ (AAA)

$$\therefore \frac{AB}{BC} = \frac{BD}{AB} \quad (\triangle ABD \parallel \triangle CBA)$$

$$\therefore AB^2 = BC \times BD$$

Similarly $\triangle ACD \parallel \triangle CBA$

and $AC^2 = DC \times CB$

$$\therefore AB^2 + AC^2 = BC \times BD + DC \times CB$$

$$AB^2 + AC^2 = BC (BD + DC)$$

$$AB^2 + AC^2 = BC \times BC$$

$$AB^2 + AC^2 = BC^2$$

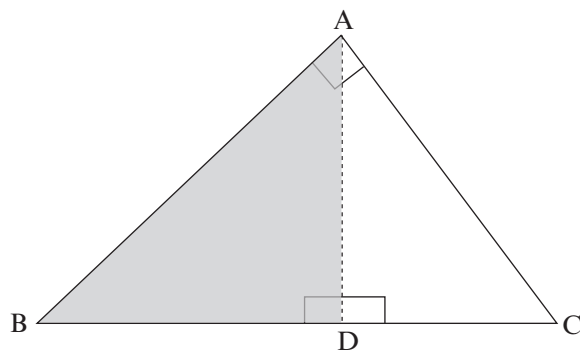



Activity 2

1.

Diameter AME of circle with centre M bisects \widehat{FAB} .
 MD is perpendicular to the chord AB .
 ED produced meets the circle at C , and CB is joined.

- a) Prove $\triangle AEF \parallel \triangle AMD$ (5)
 b) Hence, find the numerical value of $\frac{AF}{AD}$. (5)
 c) Prove $\triangle CDB \parallel \triangle ADE$ (4)
 d) Prove $AD^2 = CD \cdot DE$ (3)
 [17]

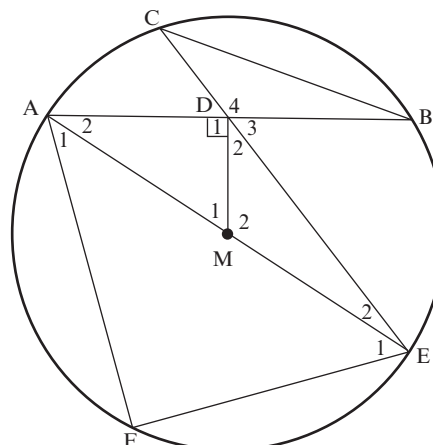

Solution

a)

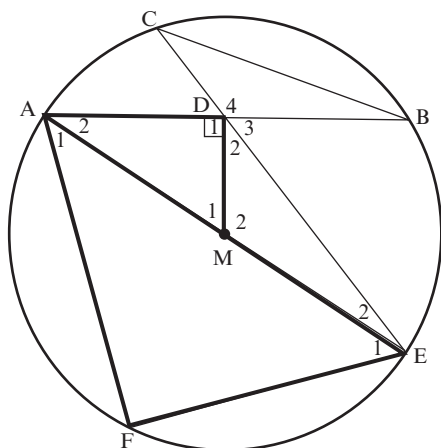

$$\widehat{F} = 90^\circ \quad (\angle \text{ in semi-circle) } \checkmark$$

$$\widehat{D}_1 = 90^\circ \quad (\text{given } MD \perp AB) \checkmark$$

$$\therefore \widehat{F} = \widehat{D}_1$$

In $\triangle AEF$ and $\triangle AMD$

$$\widehat{F} = \widehat{D}_1 \checkmark \quad (\text{proved})$$

$$\widehat{A}_1 = \widehat{A}_2 \quad (\text{AM bisects } \widehat{FAB}) \checkmark$$

$$\therefore \widehat{E}_1 = \widehat{M}_1 \quad (\text{third } \angle \text{ of } \triangle)$$

$$\therefore \triangle AEF \parallel \triangle AMD \quad (\text{AAA) or } \angle\angle\angle \checkmark \quad (5)$$

Solution

$$\text{b) } \frac{AE}{AM} = \frac{EF}{MD} = \frac{AF}{AD} \quad (\parallel \Delta\text{s}) \checkmark$$

$$AM = ME \quad (\text{radii}) \checkmark$$

$$\therefore AE = 2AM \checkmark$$

$$\therefore \frac{2AM}{AM} = \frac{AF}{AD} \checkmark$$

$$\therefore \frac{AF}{AD} = 2 \checkmark$$

(5)

Solution

c)

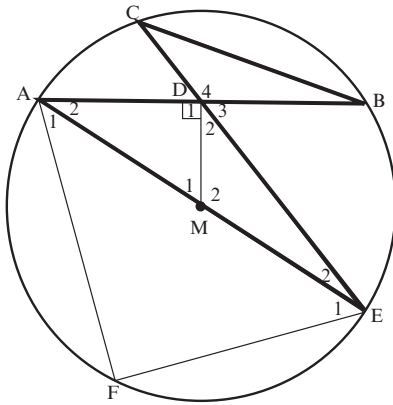

In $\triangle CDB$ and $\triangle ADE$

$$\hat{C} = \hat{A}_2 \checkmark \quad (\angle \text{ in same seg}) \checkmark$$

$$\hat{B} = \hat{E}_2 \quad (\angle \text{ in same seg}) \checkmark$$

$$\hat{D}_4 = \hat{D}_1 + \hat{D}_2 \quad (\text{opp } \angle)$$

$$\therefore \triangle CDB \parallel \triangle ADE \text{ (AAA)} \checkmark \quad (4)$$

Solution

d)

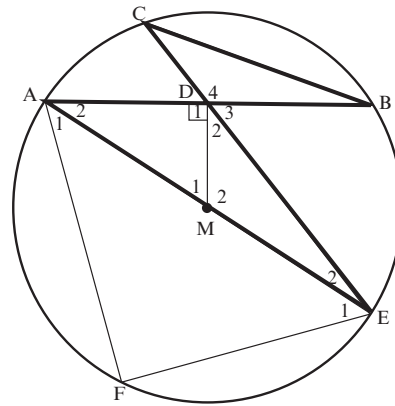

$$\frac{CD}{AD} = \frac{DB}{DE} \quad (\text{III } \Delta \text{ s})$$

$$\therefore CD \cdot DE = AD \cdot DB \checkmark$$

$$\text{But } AD = DB \quad (\text{MD} \perp \text{AB, M is centre}) \checkmark$$

$$\therefore CD \cdot DE = AD \checkmark$$

$$\therefore AD^2 = CD \cdot DE \quad (3)$$

[17]

2.

CD is a tangent to circle ABDEF at D.
 Chord AB is produced to C. Chord BE
 cuts chord AD in H and chord FD in G.
 AC \parallel FD and FE = AB.

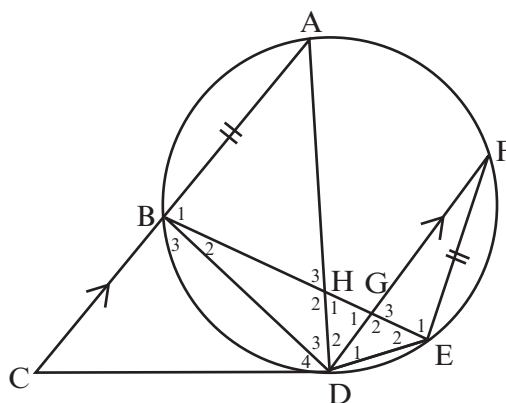

a) Prove that $\hat{D}_4 = \hat{D}_2$ (3)

b) Prove that $\triangle BHD \parallel \triangle FED$ (5)

c) Hence $\frac{AB}{BH} = \frac{FD}{BD}$ (3)

[11]

Solutions

a) $\hat{A} = \hat{D}_4$ (tan-chord thm) ✓

$\hat{D}_2 = \hat{A}$ (alt \angle s CA \parallel DF) ✓

$\hat{D}_4 = \hat{D}_2$ ✓

(3)

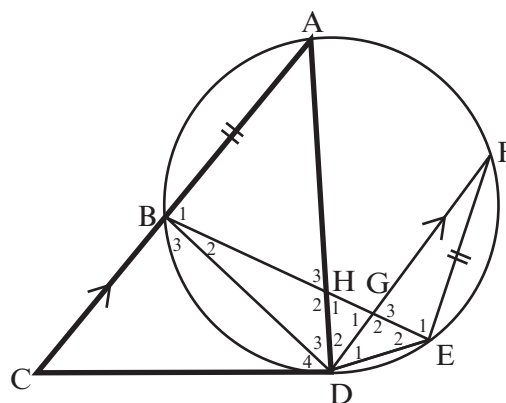
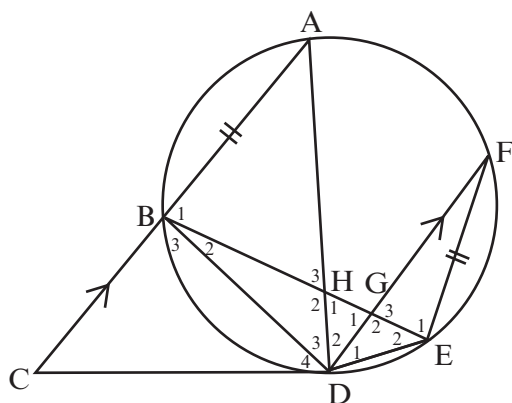

b) In $\triangle BHD$ and $\triangle FED$

$\hat{B}_2 = \hat{F}$ (\angle s in same seg) ✓

$\hat{D}_3 = \hat{D}_1$ ✓ (equal chords) ✓

$\hat{H}_2 = \hat{E}_2$ (third \angle of \triangle) ✓

$\therefore \triangle BHD \parallel \triangle FED$ $\angle\angle\angle$ ✓

(5)

c) $\frac{FE}{BH} = \frac{FD}{BD}$ ✓ ($\parallel \triangle$ s)

But FE = AB ✓ (given)

$\therefore \frac{AB}{BH} = \frac{FD}{BD}$ ✓

(3)

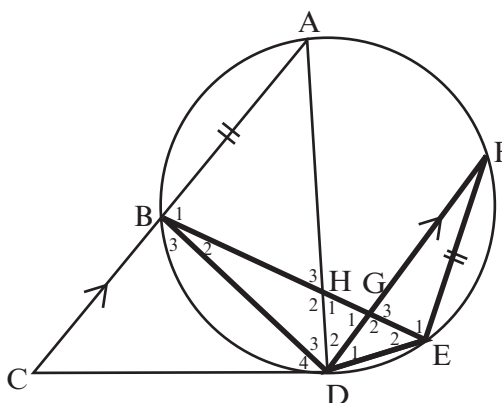

[11]

3. In the diagram $\triangle ABC$ is such that F is on AB and G is on AC. CB is produced to meet GF produced at E. DGFE is a straight line. $BFA \parallel CD$.
 $AB = 20$, $BC = 10$, $EF = 8$, $EB = 5$ and $FB = 6$.

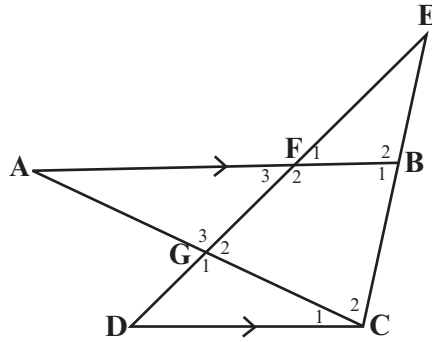

- 3.1 Determine the numerical value of $\frac{EF}{ED}$ (3)
 3.2 Calculate the length of ED (2)
 3.3 Complete, without stating the reasons: $\triangle EFB \parallel \triangle \dots$ (1)
 3.4 Hence, calculate the length of DC (3)
 3.5 Prove that: $\frac{AF}{CD} = \frac{FG}{DG}$ (4)
[13]

Solutions

$BFA \parallel CD$. $AB = 20$, $BC = 10$, $EF = 8$, $EB = 5$ and $FB = 6$

3.1

$FB \parallel CD$ (Given)
 $\frac{EF}{ED} = \frac{EB}{EC} \checkmark \text{S}$ (line \parallel one side of $\triangle A$) $\checkmark \text{R}$
 $\frac{EF}{ED} = \frac{5}{15} = \frac{1}{3} \checkmark \text{S}$ (3)

3.5

In $\triangle AFG$ and $\triangle CDG$
 $\hat{A} = \hat{C}_1$ (alt \angle s. $AF \parallel DC$) $\checkmark \text{S/R}$
 $\hat{G}_3 = \hat{G}_1$ (vertically opp \angle s) $\checkmark \text{S/R}$
 $\hat{F}_3 = \hat{D}$ (alt \angle s. $AF \parallel DC$)
 $\triangle AFG \parallel \triangle CDG$ ($\angle \angle \angle$) $\checkmark \text{R}$
 $\frac{AF}{CD} = \frac{FG}{DG}$ ($\triangle AFG \parallel \triangle CDG$) $\checkmark \text{R}$ (4)

3.2

$\frac{EF}{ED} = \frac{1}{3}$ from 3.1 and $EF = 8$
 $\therefore \frac{8}{ED} = \frac{1}{3} \checkmark$
 $ED = 24 \checkmark \text{S}$ (2)

3.3

$\triangle EFB \parallel \triangle EDC \checkmark$ (1)

3.4

$\frac{DC}{FB} = \frac{ED}{EF}$ ($\triangle EFB \parallel \triangle EDC$) $\checkmark \text{R}$
 $\frac{DC}{6} = \frac{24}{8} \checkmark \text{S}$
 $DC = 18 \checkmark \text{S}$ (3)

[13]

4. In the diagram, PQCB is a cyclic quadrilateral. Chords BP and CQ are produced to meet at A such that $AQ = BC$.

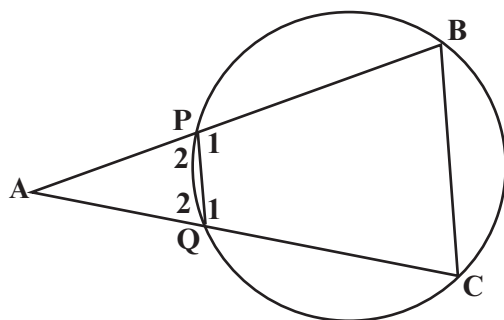

4.1 Prove that: $\triangle APQ \sim \triangle ACB$ (4)

4.2 Hence, prove that $AQ^2 = AB.PQ$ (3)

[7]

Solutions

4.1

Proof: In $\triangle APQ$ and $\triangle ACB$

$$\hat{A} = \hat{A} \quad (\text{common}) \checkmark \text{S/R}$$

$$\hat{P}_2 = \hat{C} \checkmark \text{S} \quad (\text{ext } \angle \text{ of a cyclic quad}) \checkmark \text{R}$$

$$\hat{P}_2 = \hat{B} \quad (\text{sum } \angle \text{ s of } \triangle \text{ or } (\text{ext } \angle \text{ of cyclic quad}))$$

$$\triangle APQ \sim \triangle ACB \quad (\angle.\angle.\angle) \checkmark \text{R} \quad (4)$$

4.2

$$\frac{AQ}{AB} = \frac{PQ}{BC} \checkmark \text{S} \quad (\triangle APQ \sim \triangle ACB) \checkmark \text{S}$$

$$\frac{AQ}{AB} = \frac{PQ}{AQ} \checkmark \text{S} \quad (AQ = BC)$$

$$AQ^2 = AB.PQ \quad (3)$$

[7]



Keep going!

13 Unit

Statistics

Data handling is the study of statistics, or data. We collect, organise, analyse and interpret data. The data can inform students, researchers, advertising and business.

It can provide us with an understanding of social issues and human trends. Then we can make informed decisions when we plan for the future, or make a new advertisement, or address social issues.

We usually collect data from a fairly small group (called the **sample**). The sample must be big enough and it must be randomly chosen from the population. This is to make sure that it fairly represents the trends in the larger group of people (called the **population**).

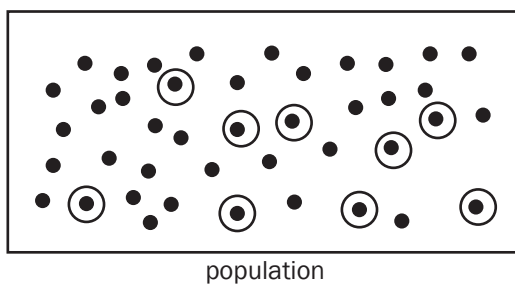

Sample:

Some data randomly chosen from population.

13.1 Bar graphs and frequency tables

Data can be represented with a frequency table or with a bar graph. Each bar represents a group of data and the bars can be compared to each other. Bar graphs must be labelled on one axis and show the numbering on the other axis.



In a Geography class, 23 learners completed a test out of 10 marks. Here is a list of their results:

4; 1; 2; 2; 6; 9; 6; 10; 6; 8; 9; 6; 7; 7; 8; 4; 6; 6; 5; 7; 9; 10; 6.

We can use a frequency table to record this data.

Frequency table

Mark out of 10	Tally	Number of learners who achieved this mark (frequency)
1	/	1
2	//	2
3		0
4	//	2
5	/	1
6	//// //	7
7	///	3
8	//	2
9	///	3
10	//	2

We can also make a bar graph to show this data. Use the marks from 1 to 10 on the horizontal axis. Use the number of learners who got that score on the vertical axis. The number of learners is the frequency.

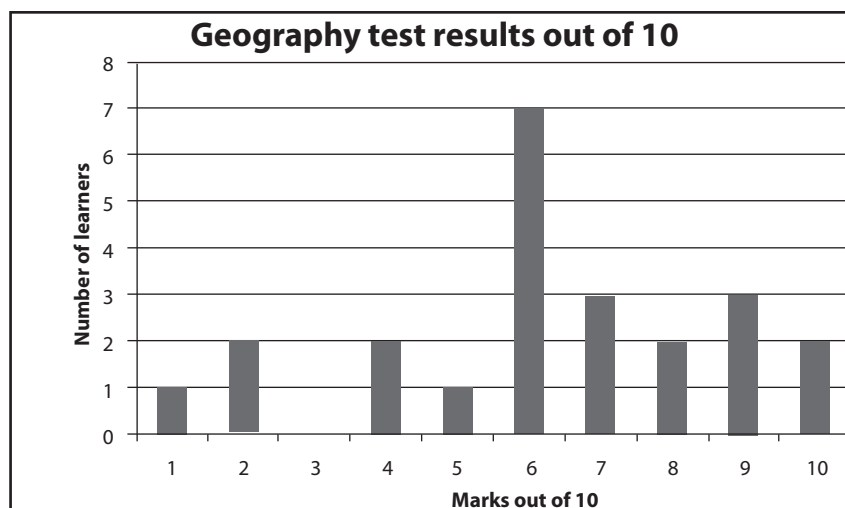

13.2 Measures of central tendency

13.2.1 Ungrouped Data

Measures of central tendency are different measures of finding the 'middle' or 'average' of a set of data. The three kinds of 'middle' of a set of data that we use are the mean, the median and the mode.

It is advisable that we start by arranging the set of data in an ascending order before attempting questions.

1. Mean

The **mean** of the data is the average if you add all the values and divide by the number of values. We use the symbol \bar{x} for the mean.

$$\text{mean } (\bar{x}) = \frac{\Sigma fx}{n}$$

This formula will be on the information sheet provided in examinations.



In a Mathematics class, 23 learners completed a test out of 25 marks. Here is a list of their results:

14; 10; 23; 21; 11; 19; 13; 11; 20; 21; 9; 11; 17; 17; 18; 14; 19; 11; 24; 21; 9; 16; 6.

Calculate the mean of this data.

Solution

$$\text{mean } (\bar{x}) = \frac{\text{sum of values in set}}{\text{number of values in set}}$$

$$= \frac{14 + 10 + 23 + 21 + 11 + 19 + 13 + 11 + 20 + 21 + 9 + 11 + 17 + 17 + 18 + 14 + 19 + 11 + 24 + 21 + 9 + 16 + 6}{23} \checkmark$$

$$= 15,4347... \checkmark (2)$$

2. Median

The **median** is the middle number in an ordered data set.

e.g. 3

In a Mathematics class, 23 learners completed a test out of 25 marks. Here is a list of their results:

14; 10; 23; 21; 11; 19; 13; 13; 20; 21; 9; 13; 17; 17; 18; 14; 19; 13; 24; 21; 9; 16; 6.

Calculate the median of this data.

Solution

- First put the data in order, from lowest to highest.

6; 9; 9; 10; 11; 13; 13; 13; 13; 14; 14; **16**; 17; 17; 18; 19; 19; 20; 21; 21; 21; 23; 24.

There are 23 numbers, so the middle number is the 12th number out of 23 numbers. So 16 is the median, the number in the middle of the data.

- When there is an even number of values in the data set, the median lies halfway between the middle two values.
- We can add these two values and divide by 2. For [Example], what if another learner wrote the test and her result was 7? We can add this to the ordered data set.

6; **7**; 9; 9; 10; 11; 13; 13; 13; 13; 14; **14; 16**; 17; 17; 18; 19; 19; 20; 21; 21; 21; 23; 24.

Now there are 24 numbers and the middle two numbers are the 12th and 13th numbers. The middle two numbers are 14 and 16. Add 14 and 16 to get 30 and divide by 2 to get a **median of 15**.

$$\frac{14+16}{2} = 15$$

3. Mode

The **mode** is the number or value that appears most frequently in the data set.

e.g. 4

In a Mathematics class, 23 learners completed a test out of 25 marks. Here is a list of their results:

14; 10; 23; 21; 11; 19; **13; 13**; 20; 21; 9; **13**; 17; 17; 18; 14; 19; **13**; 24; 21; 9; 16; 6.

Find the **mode** of this data.

Solution

The mode of the results of the test is **13**✓ (13 appears 4 times). (1)

Summary

$$\text{mean } (\bar{x}) = \frac{\sum fx}{n}$$

median: middle score of an ordered list of data

mode: the most frequent score



Activity 1

The table below represents Mathematics test scores and frequency for each score.

Scores (x)	Frequency (f)
13	5
17	6
20	4
25	10

- (a) Determine the median (2)
 (b) Determine the mean (2)
[4]

Solutions

(a) $\Sigma f = 25$ ✓ i.e. there are 25 scores. To determine the median, find the position of the median by adding the frequencies until you reach the position of the median.

Median lies in position 13, hence median = 20 ✓ (2)

(b) mean = $\frac{5(13) + 6(17) + 4(20) + (10)25}{25} = \frac{477}{25} = 19,08$ ✓✓ (2)

[4]

13.2.2 Grouped data

e.g. 5

Fifty shoppers were asked what percentage of their income they spend on groceries.

Six answered that they spend between 10% and 19%, inclusive. The full set of responses is given in the table below.

PERCENTAGE	FREQUENCY (f)
$10 < x \leq 19$	6
$20 < x \leq 29$	14
$30 < x \leq 39$	16
$40 < x \leq 49$	11
$50 < x \leq 59$	3

- (a) Calculate the mean percentage of family income allocated to groceries.
 (b) In which interval does the median lie?
 (c) Determine the mode percentage of income spent on groceries.

1. Determine midpoints of each interval. Since we do not have the exact values in grouped data, we use these approximations
 2. Add all the frequencies to get the number of items in a data set
 3. Determine the total of all



Solutions

(a)

PERCENTAGE	Midpoint Interval	Frequency f	Total (fx)
$10 < x \leq 19$	14,5	6	$14,5 \times 6 = 87$
$20 < x \leq 29$	24,5	14	$24,5 \times 14 = 343$
$30 < x \leq 39$	34,5	16	$34,5 \times 16 = 552$
$40 < x \leq 49$	44,5	11	$44,5 \times 11 = 489,5$
$50 < x \leq 59$	54,5	3	$54,5 \times 3 = 163,5$
Sum		$n=50$	$\Sigma(fx) = 1635 \checkmark$

$$\text{Mean} = \frac{\Sigma fx}{50} = 32,7 \checkmark \quad (2)$$

(b) $30 < x \leq 39 \checkmark$ (median is in position 25,5 of the data. When we add frequencies from above, then position 25,5 lies in the interval $30 < x \leq 39$) (1)

(c) $30 < x \leq 39 \checkmark$ (the interval with the highest frequency) (1)



hint

There are 50 scores. median lies between positions 25 and 26

$$6+14=20$$

$$20+16=36$$

13.3 Measures of dispersion (or spread)

The **measures of dispersion** give us information about how spread out the data is around the median. The measures of central tendency give us information about the central point of the data, but we still need to know if the data is concentrated in one place, or evenly spread out.

We first look at these measures of dispersion: **range** and **interquartile range**.

1. Range

The **range** is the difference between the highest value (or maximum) and the lowest value (or minimum) in a data set.

Range = largest value in the data set – smallest value in the data set



Find the range of the Mathematics test results:

6; 9; 9; 10; 11; 13; 13; 13; 13; 14; 14; 16; 17; 17; 18; 19; 19; 20; 21; 21; 21; 23; 24.

Solution

$24 - 6 = 18$. So the range of the test results is 18.

2. The interquartile range

- The interquartile range depends on the median. So organise the data first and find the median.
- The data is divided into four parts (quarters, which we call quartiles). First, the median (Q_2) divides the data into two halves.
- The lower quartile (Q_1) divides the data below the median (Q_2) into two equal sets of data.
- The upper quartile (Q_3) divides the data above the median into two equal sets of data.
- The difference between the lower and the upper quartile ($Q_3 - Q_1$) is called the **interquartile range**. This tells us how spread out the middle half of the data is around the median.

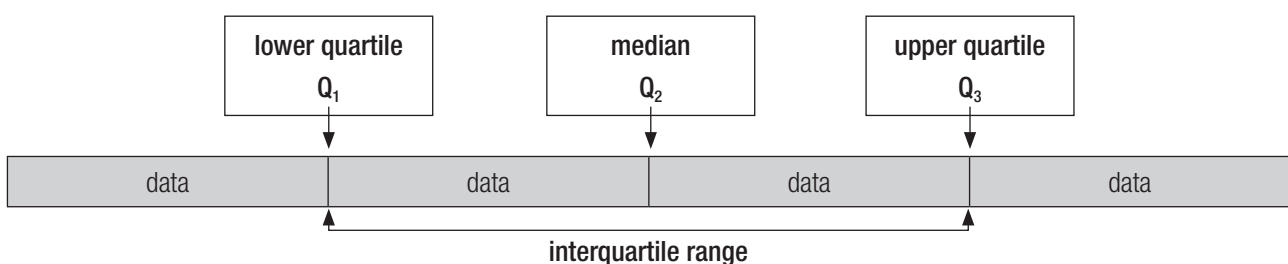

e.g. 7

Find the interquartile range of the Mathematics test results:

6; 9; 9; 10; 11; 13; 13; 13; 13; 14; 14; 16; 17; 17; 18; 19; 19; 20; 21; 21; 21; 23; 24.

Solution

- We already know that the median is 16.
- Lower half of the data has 11 scores, so Q_1 is the 6th data item.
 $\therefore Q_1 = 13$
- Upper half of the data set has 11 scores, so Q_3 is the 6th score of the upper half data set $\therefore Q_3 = 20$

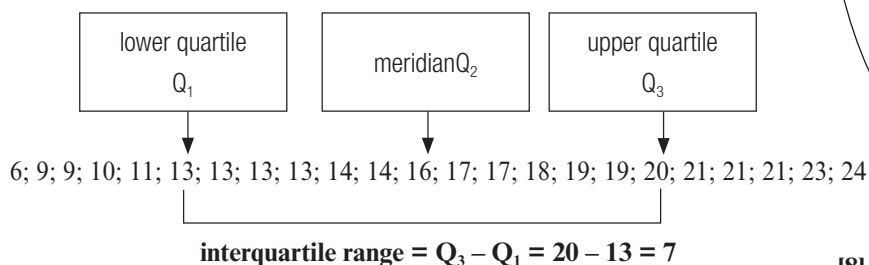

We can also use the ff formulae to calculate the position of Q_1 , Q_2 and Q_3 .

$$\text{Position of } Q_2 = \frac{(n+1)}{4} = \frac{(23+1)}{4} = 6$$

Q_2 is the value in position 6 which is 16

$$\text{Position of } Q_1 = \frac{(n+1)}{4} = \frac{(23+1)}{4} = 6$$

is the value in position 6 which is 13

$$\text{Position of } Q_3 = \frac{3(n+1)}{4} = \frac{3(23+1)}{4} = 18$$

Q_3 is the value in position 18 which is 20



NB

Median is not included in the lower half and upper half of the data when calculating Q_1 and Q_3



Activity 2

If the test scores in another class are represented by the data below, find the interquartile range of the test results:

6; 7; 9; 9; 10; 11; 13; 13; 13; 13; 14; **14; 16**; 17; 17; 18; 19; 19; 20; 21; 21; 21; 23; 24.

[8]

Solution

We already know that the middle two numbers are 14 and 16.

- The data set has an even number of points, so the median will lie between 14 and 16 (✓). Use the lower value 14 in the lower half and the upper value 16 in the upper half. (✓)
- Lower half: 12 numbers, so use the 6th and 7th numbers to find the lower quartile. $\frac{11+13}{2} = 12$ (✓)
- Upper half: 12 numbers, so use the 6th and 7th numbers to find the upper quartile. $\frac{19+20}{2} = 19,5$ (✓)

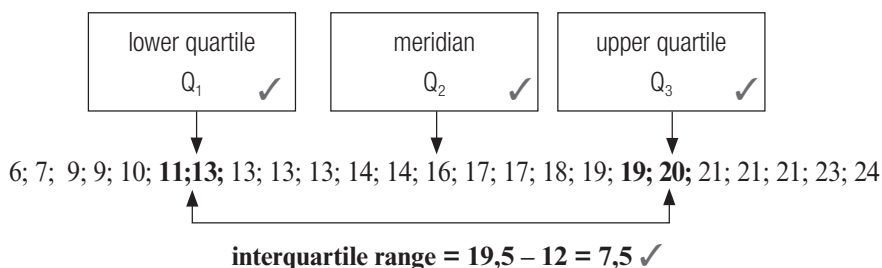

[8]



13.4 Five number summary and box and whisker plot

1. Five number summary

The **five number summary** is a 'summary' description of a data set. It is made of these five numbers:

- the minimum value
- the lower quartile
- the median
- the upper quartile
- the maximum value



What is the five number summary for the set of data we have used so far?

6; 9; 9; 10; 11; 13; 13; 13; 13; 14; 14; 16; 17; 17; 18; 19; 19; 20; 21; 21; 21; 23; 24.

- the minimum value: 6
- the lower quartile: 13
- the median: 16
- the upper quartile: 20
- the maximum value: 24

2. Box and whisker plot

We can represent the five number summary on a **box and whisker plot (or diagram)**.

The box represents the **middle half** of the data (the interquartile range)

The line in the box shows the **median**.

The 'whiskers' show the **minimum** and **maximum** values.

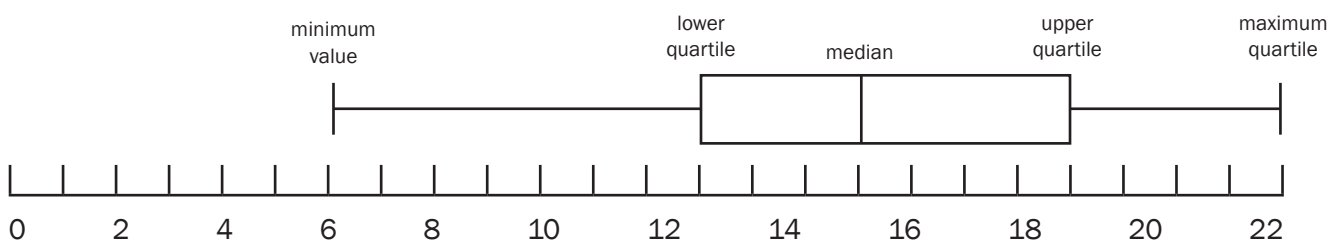

Quartiles divide data into four equal sets of data. The longer whisker and box means that the lower 50% of the scores is more spread out than the upper 50%.

Skewed to the right (Positively skewed) means that the upper half of the data is more spread out than the lower half.

Skewed data

A **box and whisker plot** can show whether a data set is symmetrical, positively skewed or negatively skewed. This box and whisker plot is *not* symmetrical because the whiskers are not the same length and the median is not in the centre of the box. The whisker on the left is a bit longer than the whisker on the right, which shows that the data on the left of the box is more spread out. The box is also longer to the right of the median than to the left of the median. We say that the data is **negatively skewed**. (or skewed to the left).

3. Identification of outliers



Determine whether the minimum in the [Example] above is an outlier or not.

Solution

$$\begin{aligned} \text{Inter-quartile range} &= Q_3 - Q_1 \\ &= 20 - 13 \\ &= 7 \\ Q_1 - 1,5 \times \text{IQR} &= 13 - 1,5 \times 7 \\ &= 2,5 \\ 6 > 2,5 \therefore 6 \text{ is not an outlier} \end{aligned}$$



To determine outliers:

- Determine the interquartile range
- Determine $Q_1 - 1,5 \times \text{IQR}$
- If the minimum $<$ the value of $Q_1 - 1,5 \times \text{IQR}$, then it is an outlier.
- Determine $Q_3 - 1,5 \times \text{IQR}$
- If the maximum $>$ $Q_3 - 1,5 \times \text{IQR}$,

Then it is an outlier.



Activity 3

1. These are the scores of ten students in a Science test:
90; 85; 10; 75; 70; 60; 78; 80; 82; 80; 55; 84
 - a) Draw a box and whisker diagram for the given data. (5)
 - b) Determine the interquartile range. (2)
 - c) State whether the data is skewed or not. (1)
 - d) State whether 10 is an outlier or not. (2)

[10]

Solutions

- a) First write all the scores in ascending order.

10; 55; 60; 70; 75; 78; 80; 80; 82; 84; 85; 90

Work out the five number summary:

Minimum number: 10

Maximum number: 90

Median: 12 numbers, so use the 6th and 7th numbers $\frac{78+80}{2} = 79$

Lower quartile: Use the first 6 numbers. The 3rd and 4th numbers are 60 and 70

Upper quartile: Use the last 6 numbers. The 3rd and 4th numbers are 82 and 84.

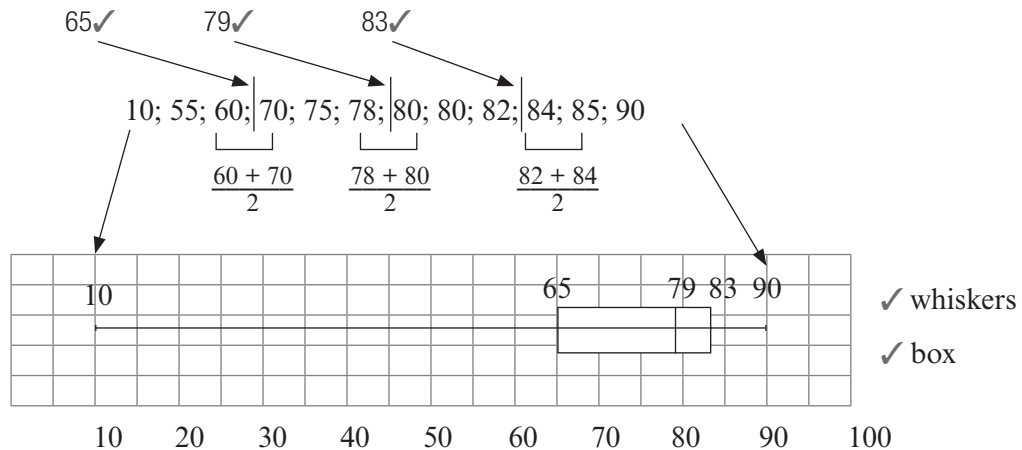

- b) Interquartile range = upper quartile – lower quartile ✓ = $83 - 65 = 18\checkmark$ (2)
- c) The data is skewed to the left (negatively skewed). ✓ (1)

The whisker on the left is longer, i.e. the length on the left of the box is longer than the length on the right.

- d) Interquartile range (IQR) = $Q_3 - Q_1$
 $= 83 - 65$
 $= 18$
 $Q1 - 1,5 \times IQR = 65 - 1,5 \times 18$
 $= 38$ ✓38
 $10 < 38$ ✓ conclusion
 $\therefore 10$ is an outlier (2)

[10]



Activity 4

The five number summary of heights of trees three months after they were planted is (23 ; 42 ; 50 ; 53 ; 75). This information is shown in the box and whisker diagram below.

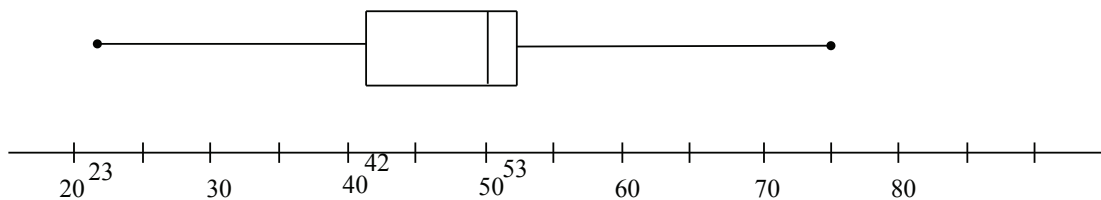

- Determine the interquartile range. (2)
- What percentage of plants has a height excess of 53 cm? (2)
- Between which quartiles do the heights of the trees have the least variation? Explain. (2)

[6]

Solutions

- Interquartile range = $53 - 42 \checkmark = 11 \checkmark$ (2)
- 25% $\checkmark\checkmark$ (2)
- Between Q_2 (50) and Q_3 (53) \checkmark The distance between these two quartiles is the smallest \checkmark (2)

[6]

13.5 Histograms and frequency polygons

- Histograms and frequency polygons are graphs used to represent grouped and continuous data. They show the frequency and the distribution (spread) of the data.
- **Continuous data** is data that is not just measured in whole numbers. For example, length, mass, volume or time are measured in continuous amounts.
- The horizontal axis of a histogram and a frequency polygon have a continuous scale.
- The vertical axis shows the **frequency**, or number of times the data is listed.

1. Grouped data:

Instead of recording every piece of data separately, we can group the data to make it easier to read. Grouped data can be represented on a histogram or a frequency polygon.



A grocer wants to record the mass of each packet of chicken pieces he sells. He groups the masses into intervals of 0,2 kg. He makes a frequency table.

Mass of chicken in kg	Number
$0,8 < \text{mass of chicken} \leq 1,0$	0
$1,0 < \text{mass of chicken} \leq 1,2$	3
$1,2 < \text{mass of chicken} \leq 1,4$	8
$1,4 < \text{mass of chicken} \leq 1,6$	6
$1,6 < \text{mass of chicken} \leq 1,8$	2
$1,8 < \text{mass of chicken} \leq 2,0$	1
$2,0 < \text{mass of chicken} \leq 2,2$	0

These 8 packets have any mass between a bit more than 1,2 kg and 1,4 kg.
So $1,2 < \text{mass of chicken} \leq 1,4$

2. Histograms

From the frequency table, he draws up a **histogram**.



A histogram is a graphical display of data using bars of different heights. It is similar to a bar graph but for a histogram there are no gaps between the bars.
x-coordinate: use upper limit of the interval
y-coordinate: frequency

Histogram of mass of chicken pieces

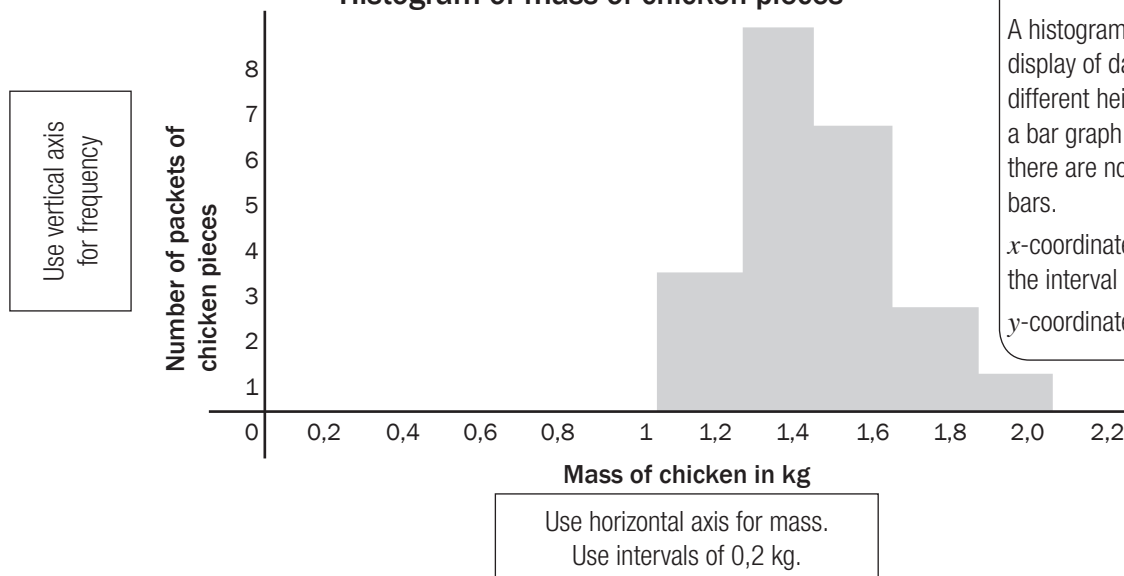

3. Frequency polygons

We can also make a **frequency polygon** using this data. A frequency polygon uses lines to join the mid-points of each interval. The polygon must begin and end on the horizontal axis. So we can add an interval at the beginning and the end of the data which both have a frequency of 0.



Notice the polygon shape. This one has 6 sides, including the *x*-axis.

Frequency polygon of mass of chicken pieces

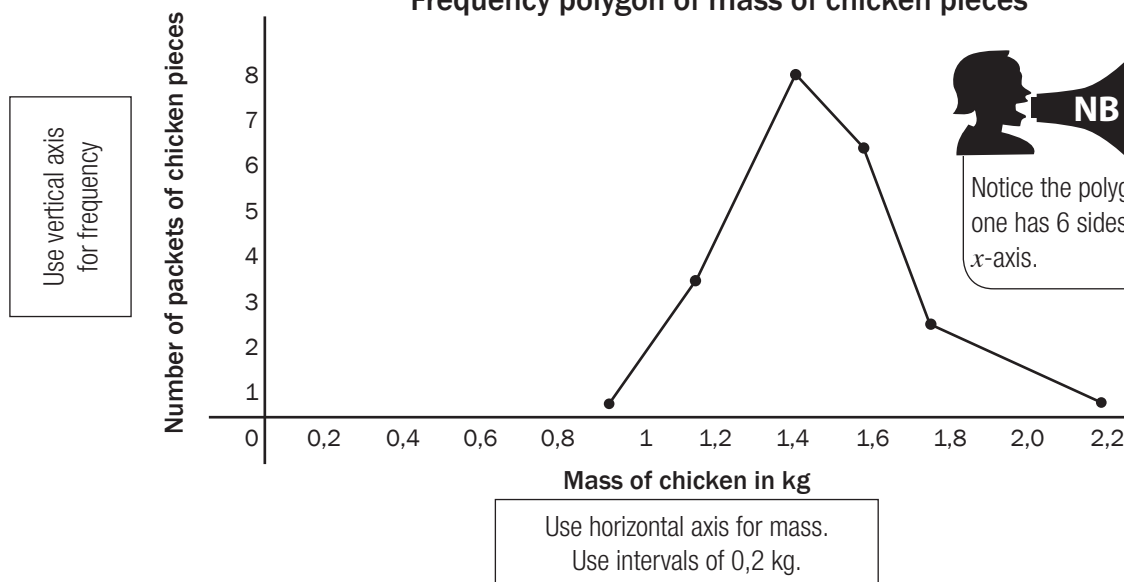

The frequency polygon can also be drawn using the midpoints of the bars of the histogram, as shown below.

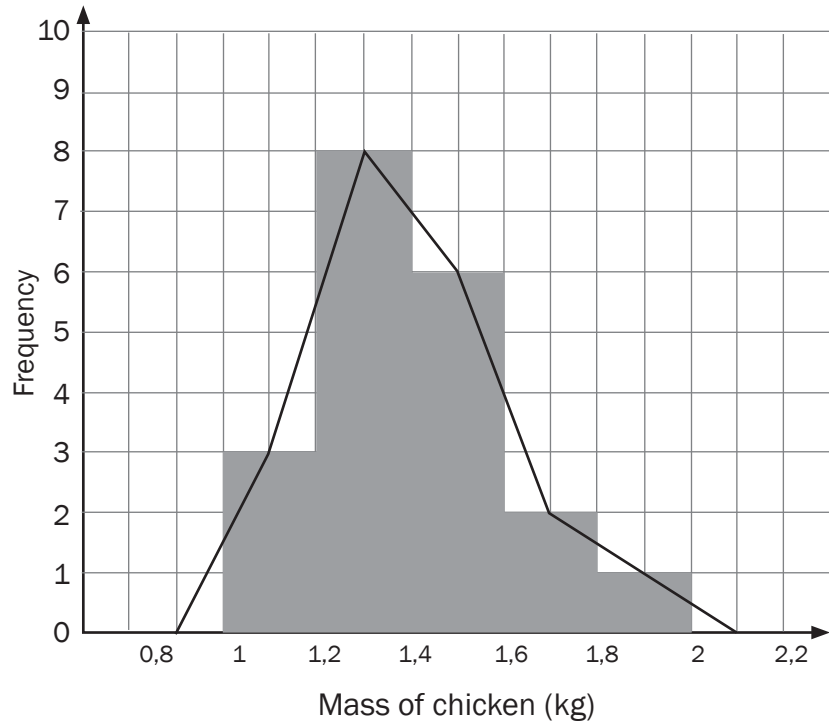

Frequency polygons are useful to compare the distribution of two or more sets of data on the same set of axes.



To plot a frequency polygon:

- Plot midpoints of each interval
- Join the midpoints by straight lines
- Add an interval at the beginning and end of the data, with both frequencies equals to 0.
- Frequency polygon is a closed figure, hence must start and end at the x -axis.

13.6 Cumulative frequency tables and graphs (ogives)

1. Cumulative frequency tables

- Cumulative frequency gives us a *running total* of the frequency. So we keep adding onto the frequency from the first interval to the last interval.
- We can show these results in a **cumulative frequency table**.

e.g. 11

In an English class, 30 learners completed a test out of 20 marks. Here is a list of their results:

14; 10; 11; 19; 15; 11; 13; 11; 9; 11; 12; 17; 10; 14; 13; 17; 7; 14; 17; 13; 13; 9; 12; 16; 6; 9; 11; 11; 13; 20.

Mark out of 20	Tally	Frequency (number of learners)	Cumulative frequency
6	/	1	1
7	/	1	$1 + 1 = 2$
8		0	$2 + 0 = 2$
9	///	3	$2 + 3 = 5$
10	//	2	$5 + 2 = 7$
11	###/	⑥	⑬
12	//	2	15
13	###	5	20
14	///	3	23
15	/	1	24
16	/	1	25
17	///	3	28
18		0	28
19	/	1	29
20	/	1	③①



Keep adding onto frequency from row before.
For example,
 $7 + 6 = 13$



The last number is the same as total number of learners

With this data set, it would be more useful to **group** the data.

We can use intervals of 5 and make a cumulative frequency table for grouped data.

Class interval	Frequency	Cumulative frequency
$1 < x \leq 5$	0	0
$5 < x \leq 10$	7	7
$10 < x \leq 15$	17	24
$15 < x \leq 20$	6	30

2. Cumulative frequency graph (ogive)

- We can represent the cumulative results from a cumulative frequency table with a **cumulative frequency graph** or **ogive**.
- This graph always starts on the x-axis and usually forms an S-shaped curve, ending with the cumulative frequency (y-value).
- The **endpoint of each interval** is plotted against the **cumulative frequency**.

e.g. 12

Represent the data in the cumulative frequency table of grouped data with a cumulative frequency graph.

- the x-axis needs the points 5; 10; 15; and 20 to mark the end of each interval.
- the y-axis represents the cumulative frequency from 0 to 30.
- For plotting the points, use the end of each class interval on the x-axis and the cumulative frequency on the y-axis. So you need to plot these points: (5; 0); (10; 7); (15; 24); (20; 30)
- Join the plotted points.

hint

To plot ogive:

- x-coordinate - use upper limit of each interval.
- y-coordinate - cumulative frequency
- If the frequency of the first interval is not 0, then include an interval before the given one and make use 0 as its frequency.

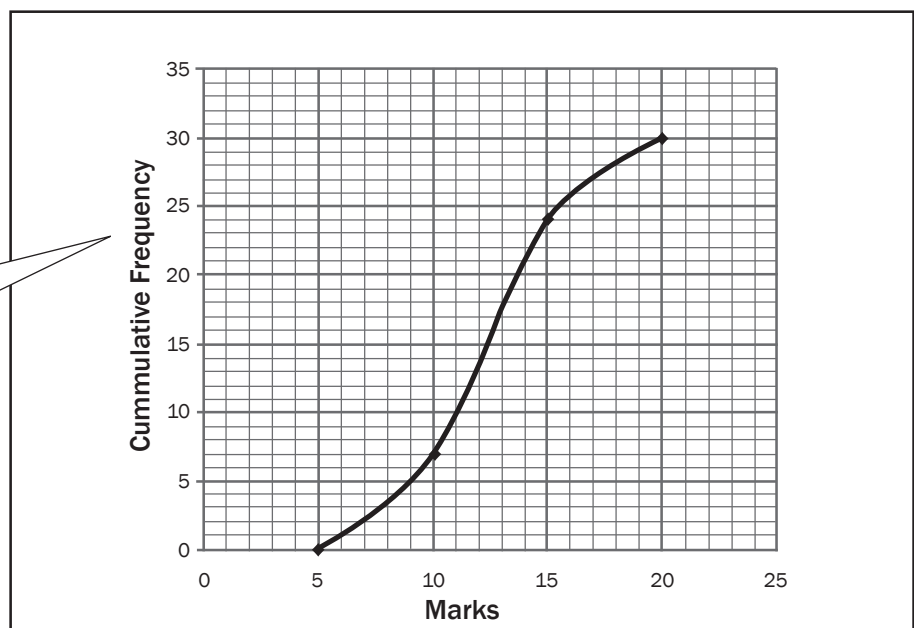



Activity 5

An ice cream vendor has kept a record of sales for October and November 2012. The daily sales in rands is shown in the histogram below.

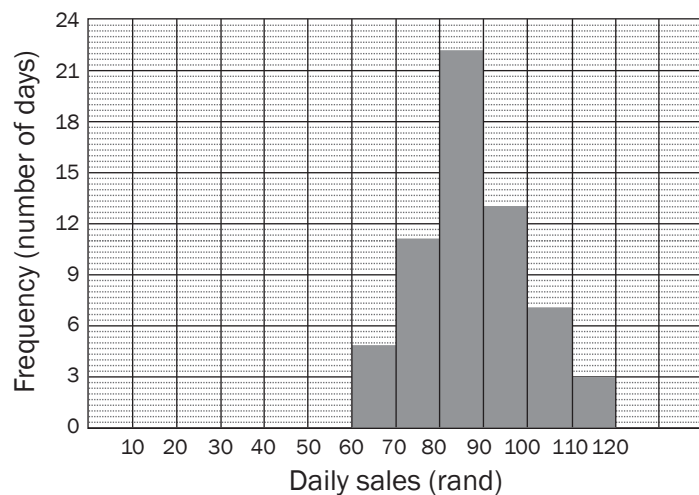

- 1.1 Draw up a cumulative frequency table for the sales over October and November. (2)
 - 1.2 Draw an ogive for the sales over October and November. (3)
 - 1.3 Use your ogive to determine the median value for the daily sales.
Explain how you obtain your answer. (1)
 - 1.4 Estimate the interval of the upper 25% of the daily sales. (2)
- [8]**

Solutions

1.1 Cumulative frequency table:

Daily sales (in rand)	Frequency	Cumulative frequency
$60 \leq \text{rand} < 70$	5	5
$70 \leq \text{rand} < 80$	11	16
$80 \leq \text{rand} < 90$	22	38 ✓ 1 st three correct
$90 \leq \text{rand} < 100$	13	51
$100 \leq \text{rand} < 110$	7	58
$110 \leq \text{rand} < 120$	3	61 ✓ last three correct

(2)

- ✓ 1st three points plotted correctly
- ✓ last three points plotted correctly
- ✓ grounding at 0



hint We can find the median, the range and the interquartile range from a cumulative frequency graph.
We cannot find the mean from a cumulative frequency graph.

1.2

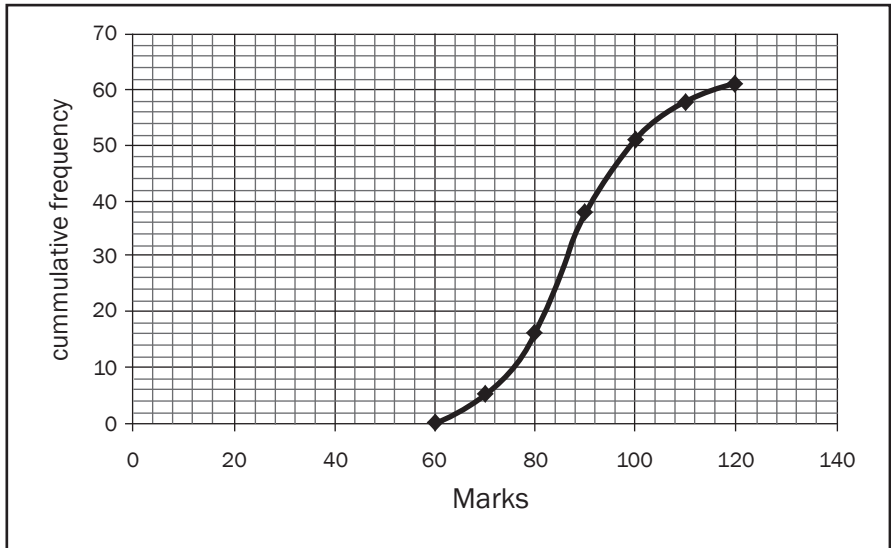

1.3 There are 61 data points, so the median is the 31st data point.

We can read the data point off the graph at 31. It gives a rand value of R87. ✓ (1)

1.4 The upper 25% lies above 75% of 61 = 45,75. ✓

Read from the y-axis across to the graph and down to the x-axis.

The upper 25% of sales lies in the interval: $96 \leq \text{sales} < 120$ ✓(2)

[8]

13.7 Variance and standard deviation

Sometimes the mean is a more useful measure of central tendency than the median.

The measures of dispersion (spread) around the mean are called the **variance** and the **standard deviation**.

1. Standard deviation

The standard deviation is the square root of (the sum of the squared differences between each score and the mean divided by the number of scores). The formula for standard deviation is:

$$\sigma = \sqrt{\frac{\sum (x - \bar{x})^2}{n}}$$

where x is each individual value, \bar{x} is the mean and n is the number of values. The symbol sigma Σ means 'the sum of'.

This formula will be on the data sheet. Make sure you can use the formula properly.

1.1 Calculating the standard deviation using the formula:

$$\sigma = \sqrt{\frac{\sum (x - \bar{x})^2}{n}}$$

1. Find the mean of all the numbers in the data set.
2. Find each value of $x - \bar{x}$. In other words, work out by how much each of these values differs (or deviates) from the mean.
3. Square each deviation. Find each value of $(x - \bar{x})^2$.
4. Add all the answers together. In other words, find $\sum (x - \bar{x})^2$.
5. Divide this sum by the number of values, n .
6. You have now found $\frac{\sum (x - \bar{x})^2}{n}$. This value is called the **variance**.
7. Find the **square root of the variance** to find the **standard deviation**. $\sqrt{\frac{\sum (x - \bar{x})^2}{n}}$

By working through these steps, you have found the standard deviation using the formula.

e.g. 13 Finding the variance and standard deviation

These are the results of a mathematics test for a Grade 11 class of 20 students.

52 44 62 66 60 57 95 78 71 62
100 69 62 72 73 55 32 83 78 80

1. Calculate the mean mark for the class. (2)
2. Complete the table below and use it to calculate the standard deviation of the marks. (3)
3. What percentage of the students scored within one standard deviation of the mean? (2)

Solutions

$$1. \bar{x} = \frac{52+44+62+66+60+57+95+78+71+62+100+69+62+72+73+55+32+83+78+80}{20} = 67,55 \checkmark$$

2.

Mark obtained (%)	$(x - \bar{x})$	$(x - \bar{x})^2$
52	$52 - 67,55$ $= -15,55$	$(-15,55)^2$ $= 241,8$
44	-23,55	554,6
62	-5,55	30,8
66	-1,55	2,4
60	-7,55	57,0
57	-10,55	111,3
95	27,45	753,5
78	10,45	109,2
71	3,45	11,9
62	-5,55	30,8
100	32,45	1053,0
69	1,45	2,1
62	-5,55	30,8
72	4,45	19,8
73	5,45	29,7
55	-12,55	157,5
32	-35,55	1263,8
83	15,45	238,7
78	10,45	109,2
80	12,45	155,0
	$\Sigma (x - \bar{x})^2$	4 962,9



The squaring of $(x - \bar{x})$ deals with the effect of the negative signs.

At the end, we find the square root of the whole answer to 'reverse' the effect of the square.

$$\sigma = \sqrt{\frac{4\,962,9}{20}} = 15,7526\dots$$

$$= 15,75 \quad \checkmark\checkmark\checkmark \text{ answer}$$

(correct to 2 decimal places)

3. One standard deviation from the mean lies between

$$(\bar{x} - \sigma; \bar{x} + \sigma) = (67,55 - 15,75; 67,55 + 15,75)$$

$$= (51,8; 83,3) \quad \checkmark$$

16 scores lie in the interval (51,8; 83,3)

16 out of 20 of the marks lie within one standard deviation of the mean, $\frac{16}{20} \times 100 = 80\% \checkmark$

Answer: 80% of the students' marks lie within one standard deviation from the mean.



We can say this is a representative set of data, because more than 66,6% lie within one standard deviation of the mean.

1.2 Steps for calculating the standard deviation with a scientific calculator:

Using a Casio $fx-82$ ES PLUS calculator:

press **Mode** then **STAT** then **1 - VAR**

- enter all data one at a time pressing = after each entry.
- press the orange **AC** button
- press **shift STAT** then **VAR**
- in order to calculate the mean press **2: \bar{x}** .
- once all these steps have been completed, simply press **AC shift STAT** then **VAR**
- now press **3: σ** to calculate the standard deviation.

If you understand the calculator steps and use them properly, you will come to the same answer of 15,75 as we found before.

Practise these steps so that you can do exam Examples using a calculator.



- the **interquartile range** measures a spread around the **median**, so it has to do with the positions of data and *not* their actual values.
- the **standard deviation** measures a spread around the **mean**, using the actual values of the data and not just their positions.



Activity 6

The data below shows the energy levels, in kilocalories per 100 g, of 10 different snack foods.

440 520 480 560 615 550 620 680 545 490

- (a) Calculate the mean energy level of these snack foods. (2)
 (b) Calculate the standard deviation. (2)
 (c) The energy levels, in kilocalories per 100 g, of 10 different breakfast cereals had a mean of 545,7 kilocalories and a standard deviation of 28 kilocalories. Which of the two types of food show greater variation in energy levels? What do you conclude? (2)

[6]

Solutions

- (a) Mean = $\frac{5500}{10} = 550$ kilocalories ✓✓ (2)
 (b) $\sigma = 69,03$ kilocalories ✓✓ (2)
 (c) Snack foods have a greater variation. ✓ The standard deviation for snack foods is 69,03 kilocalories whilst the standard deviation for breakfast cereals is 28 kilocalories. i.e energy levels of breakfast cereals is spread closer to the mean than in those of the snack food. ✓ (2)

[6]

2. The normal distributive curve

The data can be plotted on a graph that shows the standard deviations. If the data is distributed symmetrically around the mean, the values form a **normal distribution curve**:

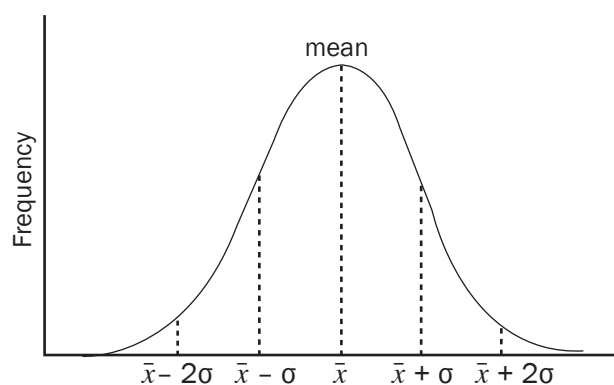

13.8 Bivariate data and the scatter plot (scatter graph)

- A **scatter plot** is a graph using the x - and y -axes to represent **bivariate** data.
- Bivariate data means that each point on the graph represents **two variables** that are **independent** of each other.
- In a scatter plot, we plot a point for each pair of coordinates and look at the overall pattern or **trend** in the data.
- The points in the data are compared to see if there is a **correlation** or some kind of pattern (or trend) in the data.
- When a point does not fit the trend of the other points, it is called an **outlier**.
- **Outliers** are easy to identify on a scatter diagram or a box and whisker diagram.
- We can sometimes represent the trend in the data with a line or curve of **best fit**. The line or curve can be represented by an equation that could be linear, quadratic, exponential, hyperbolic etc.

14

A science teacher compares the marks for the mid-year examination with the marks for final examinations achieved by 11 learners.

mid-year marks	80	68	94	72	74	83	56	68	65	75	88
final marks	72	71	96	77	82	72	58	83	78	80	92

1. Draw a scatter graph of this data. (3)
 2. Describe the curve of best fit. (2)
 3. Use the scatter plot to estimate the final mark of a learner who had a midyear mark of 75%. (1)
- [6]**

Solutions

1.

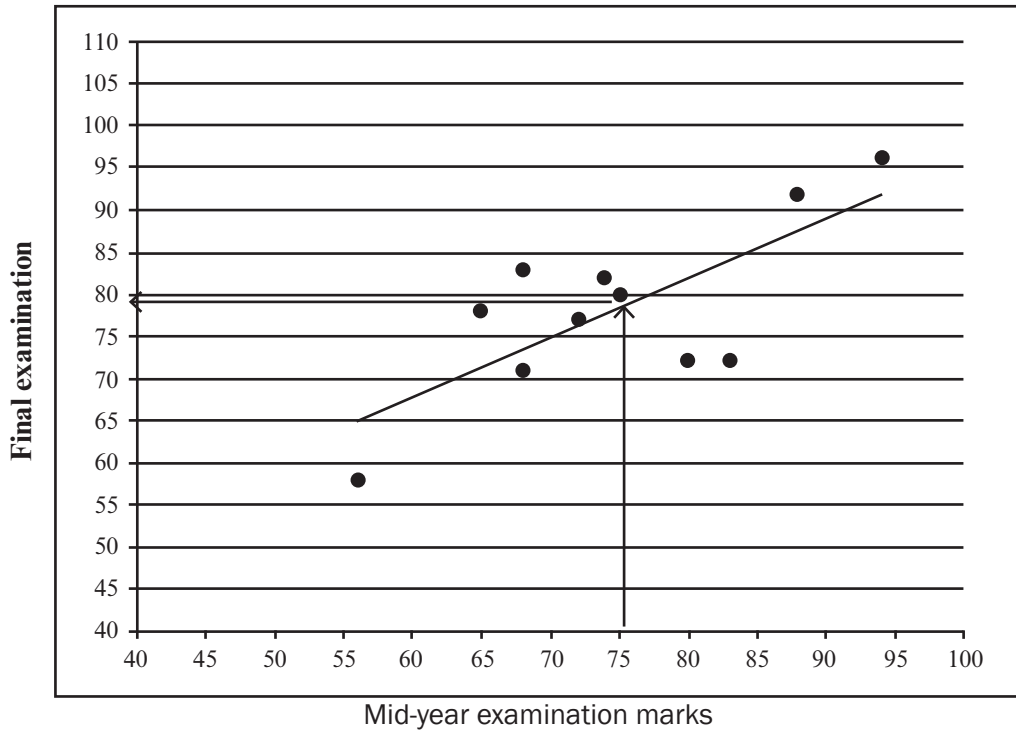

✓✓✓ all points plotted correctly

2. The 'curve' or line of best fit is a straight line. ✓ There should be about five dots above the line and five dots below the line. ✓
3. A line from 75 on the x-axis to the trendline takes us to about 78 on the y-axis. So we can predict that a learner with a midyear mark of 75% can expect to get about 78% ✓ in the final exam.

[6]



Activity 7

The outdoor temperature (in °C) at noon is measured. It is compared with the number of units of electricity used to heat a house each day.

Temp in °C	7	11	9	2	4	7	0	10	5	3
units of electricity used	32	20	27	37	32	28	41	23	33	36

- (a) Draw a scatter graph to represent this data. (3)
 (b) Draw in a line of best fit. (1)
 (c) Use your line of best fit to estimate the noon temperature when 30 units of electricity are used. (1)
[5]

Solutions

- (a) Graph ✓✓✓ (3)
 (b) Line of best fit ✓ (1)

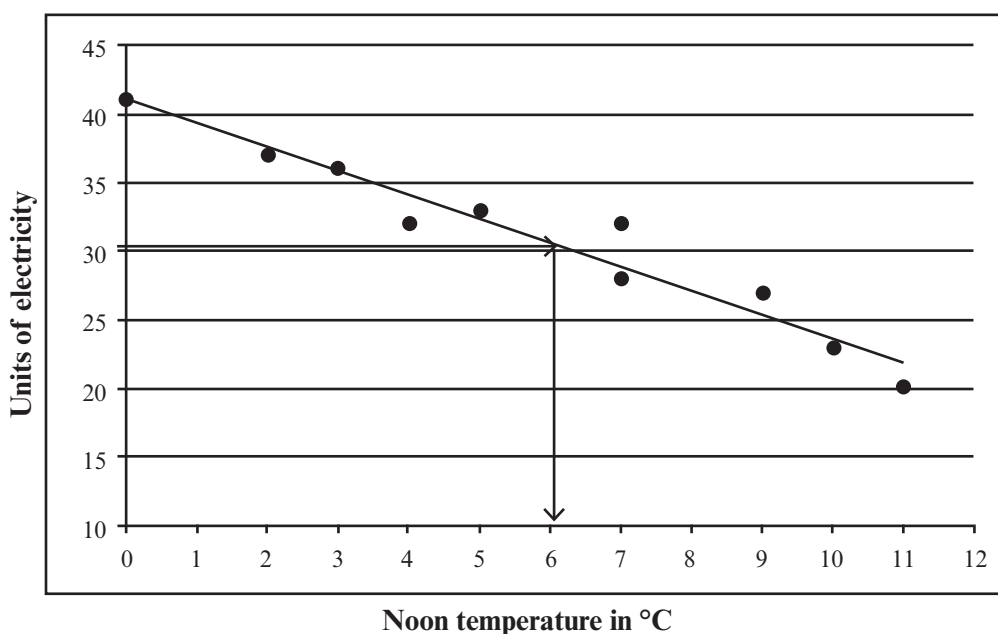

- (c) If the noon temperature is 6,25°C, about 30 units ✓ of electricity will probably be used in the house. (1)

[5]

13.9 The linear regression line (or the least squares regression line)

The line of best fit for a set of bivariate numerical data is the linear regression line. So far, we have seen this trend line on a scatter graph. Now we use a scientific calculator to determine the equation for this line.

We know the straight line equation: $y = mx + c$

Statistics (as used on the CASIO x-82ES PLUS calculator) uses $y = A + Bx$, where B is the gradient and A is the cut on the y -axis of the straight line of best fit.

So the gradient is B instead of m and the y -intercept is A instead of c .

The Regression Coefficient 'r'

This is a statistical number that measures the strength of the correlation (relationship) between two sets of data.

- This number is calculated from two sets of data using a calculator.
- r always lies between -1 and $+1$.
- The closer r is to -1 , the stronger the negative correlation.
- The closer r is to $+1$, the stronger the positive correlation.
- If $r = 0$, there is no correlation between the two sets of data.

The number line shows the r values and the strength of the correlation between bivariate data.

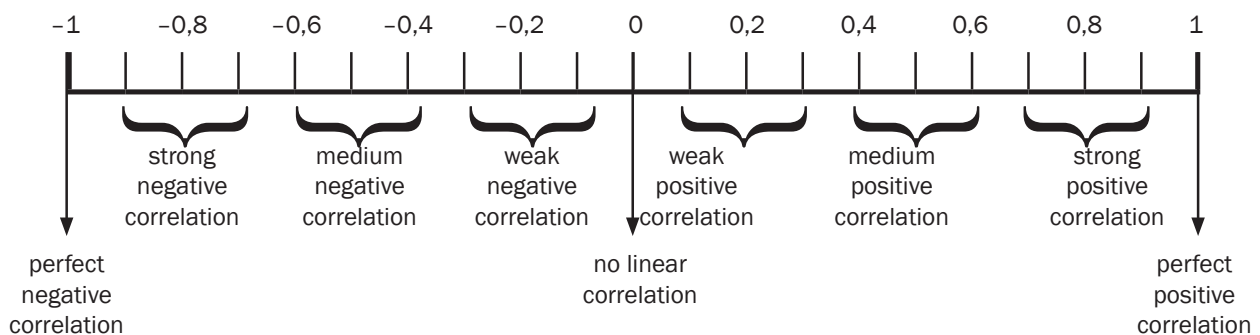

We only study the r value of bivariate data when the line of best fit is a straight line.

A negative correlation means that as x increases, y decreases.

The more closely the points are clustered together around the line, the stronger the correlation.

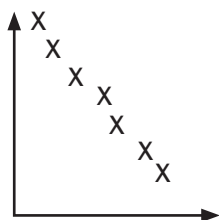

A strong negative correlation

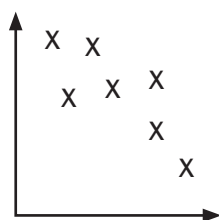

A weaker negative correlation

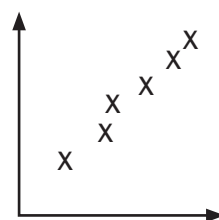

A strong positive correlation

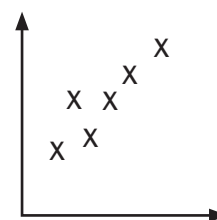

A weaker positive correlation

A positive correlation means that as x increases, y also increases

A correlation of zero means that there is no relationship between x and y .

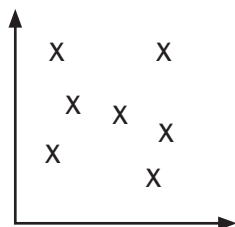

e.g. 15

A diesel engine turns at a rate of x revolutions per minute. The corresponding horse power of the engine is measured by y in the table below:

x (revolutions per minute)	400	500	600	700	750
y (horse power)	580	1 030	1 420	1 880	2 100

- Find the equation of the least squares regression line: $y = A + Bx$ (correct to two decimal places).
- Determine the regression coefficient r . Discuss the correlation between x and y .
- Use this regression line to estimate the power output when the engine runs at 800 rev per min.
- About how fast is the engine running when it has an output of 1 200 horse power?

Solutions

1. Use a calculator
 - Mode 2: STAT
 - 2: A + B x
 - Enter the x values first:
 - 400 =; 500 =; 600 =; 700 =; 750 =
 - Use arrows to move right to y column and up to start next to 400.
 - Enter y values:
 - 580 =; 1030 =; 1420 =; 1880 =; 2100 =
 - Press (orange) AC button
 - Press SHIFT STAT (at 1)
 - Press 5: Reg
 - Press 1: A = and get -1145,792683

This is the y-intercept of the regression line

- Press orange AC button
- Press SHIFT STAT
- Press 5: Reg
- Now press 2: B = and get 4,318292683

This is the gradient of the regression line

Answer:

The least squares regression line:

$y = -1\ 145,8 + 4,32\ x$ (correct to 2 decimal places)

2. Keep all the information in the calculator from 1.
 - Press AC
 - SHIFT STAT
 - 5:REG
 - Then 3: $r = 0,9996821357$

There is a strong positive correlation between x and y (r is very close to +1)

3. Substitute $x = 800$ into line of best fit equation:
 - $y = -1\ 145,8 + 4,32(800)$
 - $y = 2\ 310,2$
 - 800 revolutions will generate 2 310,2 output of horse power.*

4. Let $y = 1\ 200$
 - $1\ 200 = -1\ 145,8 + 4,32\ x$
 - $1\ 200 + 1\ 145,8 = 4,32\ x$
 - $2\ 345,8 = 4,32\ x$
 - $\frac{2\ 345,8}{4,32} = x$

$543,0092593 = x$
There are about 543 revolutions per min for an output of 1 200 horse power.

Remember to change the MODE back to 1:COMP when doing normal calculations

The scatter plot and the line of best fit show the trend in the relationship between the revolutions and the horse power.

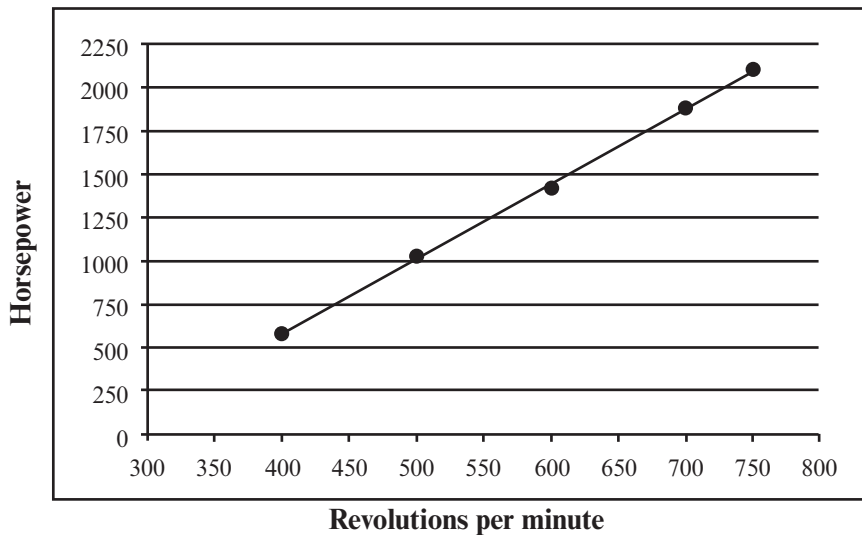



Activity 8

1. Pick 'n Pay wants to survey how long in seconds (y) it takes a teller to scan (x) items at the till.

The table shows the results from 9 shoppers.

Shoppers	A	B	C	D	E	F	G	H	I
x (no of items)	5	8	12	15	15	17	20	21	25
y (time in seconds)	3	11	9	6	15	13	25	15	13

- Use your calculator to determine the equation of the line of best fit (the regression line or the least squares regression line) correct to two decimal places. (3)
 - Calculate the value of r , the correlation coefficient for the data. What can you say about the correlation between x and y ? (3)
 - How long would the teller take to scan 21 items at the till? (2)
 - How many items could a teller scan in 21,28 seconds? (2)
2. A restaurant wants to know the relationship between the number of customers and the number of chicken pies that are ordered.

number of customers (x)	5	10	15	20	25	30	35	40
number of chicken pies (y)	3	5	10	10	15	20	20	24

- Determine the equation of the regression line correct to two decimal places. (3)
- Determine the value of r , the correlation coefficient. Describe the type and strength of the correlation between the number of people and the number of chicken pies ordered. (3)
- Determine how many chicken pies 100 people would order. (2)
- If they only have 12 pies left, how many people can they serve? (2)

[20]

Solutions

1. a) $A = 2,68$ ✓
 $B = 0,62$ ✓
 $y = 2,68 + 0,62x$ ✓ (3)

b) $r = 0,62847\dots = 0,63$ ✓✓
 This is a weak positive correlation ✓ (3)

c) $y = 2,68 + 0,62(21)$ ✓ = 15,7
 (about 16 seconds) ✓ (2)

d) $21,28 = 2,68 + 0,62x$ ✓
 $21,28 - 2,68 = 0,62x$
 $\frac{18,6}{0,62} = x$
 $30 = x$
 30 items can be scanned in 21,28 seconds. ✓ (2)

2. a) $A = -0,39285\dots$ ✓
 $B = 0,61190$ ✓
 $y = -0,4 + 0,6x$ ✓ (3)

b) $r = 0,9866\dots$ ✓✓
 This is a very strong positive correlation ✓
 (r is close to +1) (3)

c) $y = -0,4 + 0,6x$
 $y = -0,4 + 0,6(100)$ ✓
 $y = 59,6$
 About 60 chicken pies are ordered by 100 ✓ people. (2)

d) $12 = -0,4 + 0,6x$ ✓
 $12 + 0,4 = 0,6x$
 $\frac{12,4}{0,6} = x$
 $20,6\dots = x$
 About 21 people will order 12 pies. ✓ (2)

[20]



Activity 8 (continued)

3. A recording company investigates the relationship between the number of times a CD is played by a national radio station and the national sales of the same CD in the following week. The data below was collected for random sample of CDs. The sales figures are rounded to the nearest 50

Number of times CD is played	47	34	40	34	33	50	28	53	25	45
Weekly sales of the CD	3 950	2 500	3 700	2 800	2 900	3 750	2 300	4 400	2 200	3 400

- Identify the independent variable. (1)
- Draw a scatter plot of this data. (3)
- Determine the equation of the least squares regression line. (3)
- Calculate the correlation coefficient. (2)
- Predict, correct to the nearest 50, the weekly sales for a CD that was played 45 times by the station in the previous week. (2)
- Comment on the strength of the relationship between the variables. (1)

[12]

Solutions

3. a) the number of times the CD is played ✓ (1)

b)

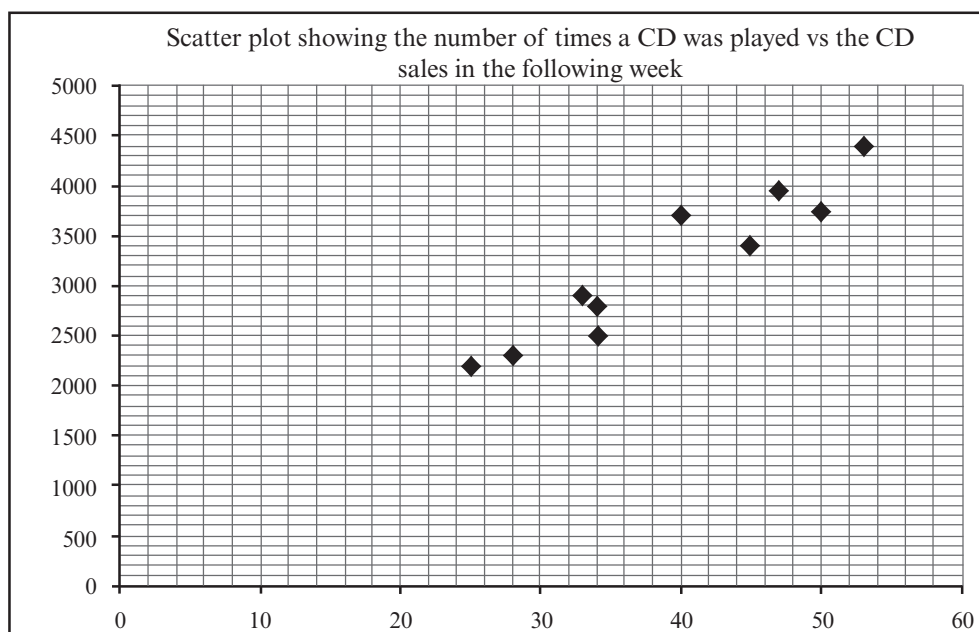

✓✓✓

(3)

c) $a = 264,326$ ✓

$b = 75,21$ ✓

$y = 264,33 + 75,21x$ ✓ (3)

d) $r = 0,95$ ✓✓ (2)

e) $y = 264,33 + 75,21x(45)$ ✓ (substitution)
 $\approx 3\,648,78$
 $\approx 3\,648$
 $\approx 3\,650$ (to the nearest 50) ✓ (2)

f) There is a very strong positive relationship between the number of times that a CD was played and the sales of that CD in the following week. ✓ (1)

[12]

What you need to be able to do:

1. Determine mean, median and mode in grouped or ungrouped data
2. Draw and analyse the following methods for representing data:
 - box-and-whisker plots
 - histograms
 - frequency polygons
 - cumulative frequency curves (ogives)
 - Calculate the variance and the standard deviation of a set of ungrouped data.
 - Comment on whether a data set is symmetric or skewed, by analysing the representation of the data.
 - Identify outliers in a set of data by looking at the box-and-whisker plot or scatterplot.
 - Determine the equation of the line of best fit of bivariate data using a calculator. (This line could be called the “least squares regression line”.)
 - Determine the regression correlation coefficient “ r ”.
 - Use the line of best fit to draw conclusions.

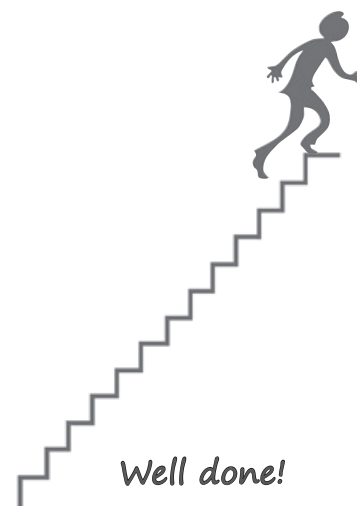



The Mind the Gap study guide series assists you to make the leap by studying hard to achieve success in the Grade 12 exam.

This publication is not for sale.

© Copyright Department of Basic Education www.education.gov.za

This publication has a Creative Commons Attribution NonCommercial Sharealike license.

Call Centre 0800 202 933



basic education

Department:
Basic Education
REPUBLIC OF SOUTH AFRICA